



WORLD'S LEADING AIR CONDITIONING  
COMPANY FROM JAPAN

PRESENTING THE NEW

**VRV X**

Heat Pump | Cooling Only



**ADVANTAGE**

**X' TENSIVE**  
RANGE

**X' TRA**  
POWER SAVINGS

**X' CELLENT**  
TECHNOLOGY

**X' TENDED**  
RELIABILITY

# INDEX

WHAT DAIKIN STANDS FOR .....	2
SALIENT FEATURES .....	6
OUTDOOR UNIT LINE-UP .....	19
INDOOR UNIT LINE-UP .....	20
SPECIFICATIONS .....	48
OUTDOOR UNIT COMBINATIONS .....	70
OPTION LIST .....	72
CONTROL SYSTEMS .....	76
AIR TREATMENT EQUIPMENT LINE-UP .....	100

# VRV X

Equipped with advanced technology, that results in high energy efficiency. This technological innovation gives end user the advantage of better comfort and works further towards creating a sustainable environment.



# WHAT DAIKIN STANDS FOR

## The world leader in air conditioning

At Daikin, we are a leading innovator and provider of advanced, high-quality air conditioning solutions for residential, commercial and industrial applications.

As world's leading air conditioning company, we are committed to deliver air conditioning solutions that enhance the quality of life all around the world.

Established in 1924, Daikin Industries Ltd., is a diverse multinational company, active in air conditioning, chemicals and oil hydraulics. With headquarters at Osaka, Japan, our Daikin family has more than 84,870 members, working across 100+ production bases and 316 consolidated subsidiaries worldwide.

As the world's sole manufacturer that develops a long line of products from refrigerants to air conditioners, we advocate comfortable living on the strength of advanced technologies.

We are present in USA, Europe and Russia, The Middle East, Africa, Asia, Oceania and Middle-South America. We aim to serve our customers in each of these markets by providing optimal air conditioning solutions.



### EUROPE / MIDDLE EAST / AFRICA



Daikin Europe N.V.



Daikin Air conditioning France



Daikin Air conditioning Germany



Daikin Air conditioning Central Europe



Daikin Air conditioning Spain



Daikin Air conditioning Italy



Daikin Air conditioning UK



Daikin Industries Czech Republic



Daikin Chemical France

### CHINA



Daikin (China) Investment

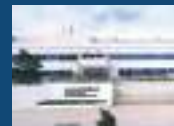

Daikin Air conditioning Shanghai



Xi'an Daikin Qing'an Compressor



Hui Zhou Daikin Suns Air conditioning



Daikin Device (Suzhou)



Daikin Fluoro Coating Shanghai



Daikin Fluorochemicals China



ASIA / OCEANIA



Daikin Air conditioning India



Daikin Compressor Industries



Daikin Air conditioning Singapore



Daikin Australia



Daikin Industries Thailand



Daikin Industries Head Office Japan (Inside Umeda Centre Building)

NORTH AMERICA / CENTRAL & SOUTH AMERICA



Daikin America



Daikin AC America



Daikin Holding USA

# Exploring new R&D frontiers

At Daikin, we are creating value through innovative technologies. As a global industry front-runner, we are carrying out research and development on the world's most advanced air conditioning technology.

Our strong R&D edge has helped us create futuristic products that enrich people's lives. As symbolised by the VRV, Daikin has put forth a multitude of products and varied technology that have always been and continue to be, at the forefront of innovation.

To be able to offer such products and services that delight and astound our customers, we have constructed an advanced R&D architecture.



Formation of a three-division system of research, IT and development to support our superior products.

To create more advanced functions and new value, we have instituted specialised R&D divisions: the 'Environmental Technology Research Laboratory' and the 'Solution Product Development Centre'.

In combination with the product development group, each of the three divisions work in close co-operation to precisely ascertain the customers' needs and to enable commercialisation of products, incorporating advanced technology that take the lead over our competitors.

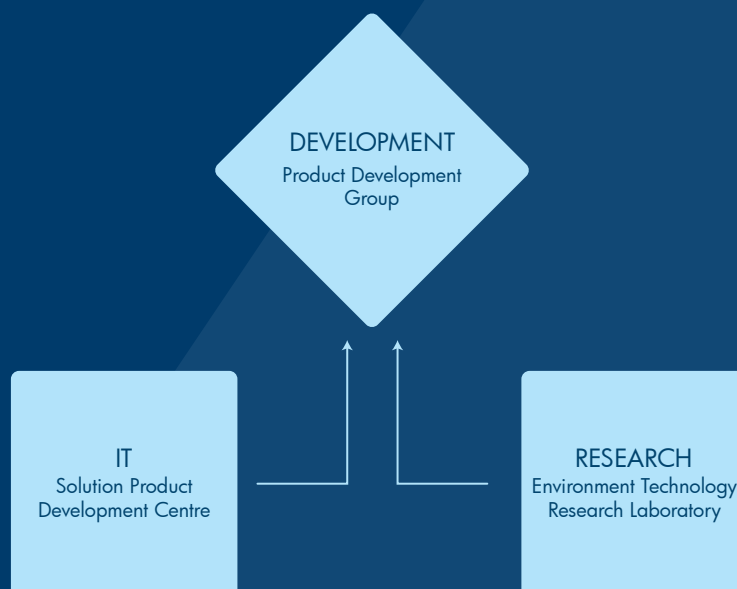

Environmental Technology Research Laboratory: Intensive Research on Environmentally Conscious, Energy Saving Air Conditioning Technology.

Accelerating globalisation of our air conditioning business and varied needs of customers across geographies are increasing our research challenges. We have established a research laboratory devoted to the two fields of 'air conditioning' and 'the environment'. With our mission to promote energy savings in air conditioners, we are engaged in R&D on cutting-edge technologies. Our aim is to create futuristic products from fundamental research on motor inverters and other areas to support individual product development.

Going forward, we will elevate our technology edge to achieve further business expansion globally.

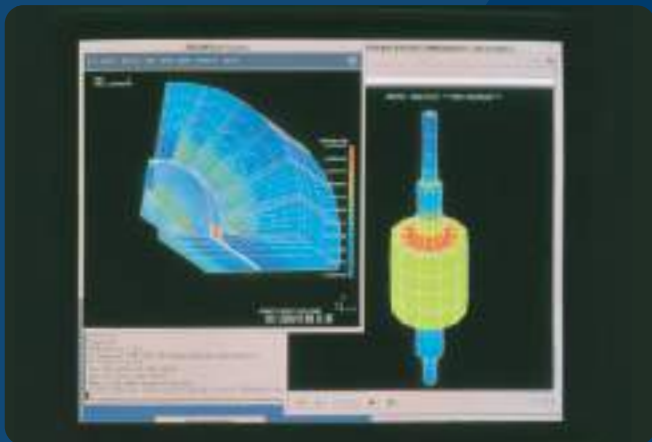

The Solutions Product Development Centre: Integrating Air conditioners with IT.

Keeping in mind the changes in business brought in by the computerisation and networking of society, we have integrated IT into our airconditioners, including communication technology, software technology and digital control. We are initiating R&D that will offer new system services—a comfortable environment with superior energy savings by networking air conditioners. Such a scenario will enable them to exchange information with service centres.



Technology & Innovation Centre, Japan:

Aiming for new value creation as a core base for technology development.



Research & Development Centre, India:

Reiterating to its commitment to Indian market, Daikin India R&D is dedicated to provide customised solutions to its customers.

# SALIENT FEATURES



World's most advanced **VRV X** air conditioning system with innovative VRT technology.

First launched in Japan in 1982, the Daikin VRV system has been embraced by the world markets for over three decades. Now, we at Daikin introduce the next generation VRV X system to reinforce our industry leadership. The system offers an enhanced line-up to meet an ever widening variety of needs, while improving energy savings, comfort and ease of installation.

The VRV X is the most advanced air conditioning system in the world and is ideal for small and large spaces.

## Energy saving technology for VRV X System

### **X' TRA POWER SAVINGS**

Next Generation  
Compressor &  
VRT Smart Control

### **VRT-Variable Refrigerant Temperature in Indoor Unit (IDU) and Outdoor Unit (ODU)**

The new VRV X system now features VRT technology in IDU & ODU. VRT automatically adjusts refrigerant temperature to individual building load and climate requirement, thus further improving annual energy efficiency and maintaining comfort. With this technology, running costs are reduced.

### **X' TENSIVE RANGE**

Up to 60 HP

### **X' CELLENT TECHNOLOGY**

4D Inverter  
System

### **X' TENDED RELIABILITY**

Auto-Optimisation  
Refrigerant  
Charging

## Standard Type

New series with compact and light weight design  
6 HP-60 HP with 56 models line-up (For Heat Pump & Cooling Only)



Installation Space	0.95 m <sup>2</sup>
Product Weight*	285 kg

\*For cooling only model



### Line-up

HP	6	8	10	12	14	16	18	20	22	24	26	28	30	32	34	36	38	40	42	44	46	48	50	52	54	56	58	60
Cooling Only/ Heat Pump	●	●	●	●	●	●	●	●	●	●	●	●	●	●	●	●	●	●	●	●	●	●	●	●	●	●	●	●

# X' TRA POWER SAVING

## New heights in energy efficiency during actual operation

The key to innovative energy savings is to increase efficiency during low-load operation.

Using data gathered from actual operation, Daikin discovered that air conditioning systems operate at a load factor of 50% or less for 70% of their annual operation period.

This inspired us to develop new technologies to enhance energy efficiency during low loads.

Utilising these technologies, Daikin's new VRV X series raise the standard for energy efficiency.

•Correlation between the load factor for the rated capacity and operation time  
\*According to a survey by Daikin (based on Air Conditioning Network Service System data)

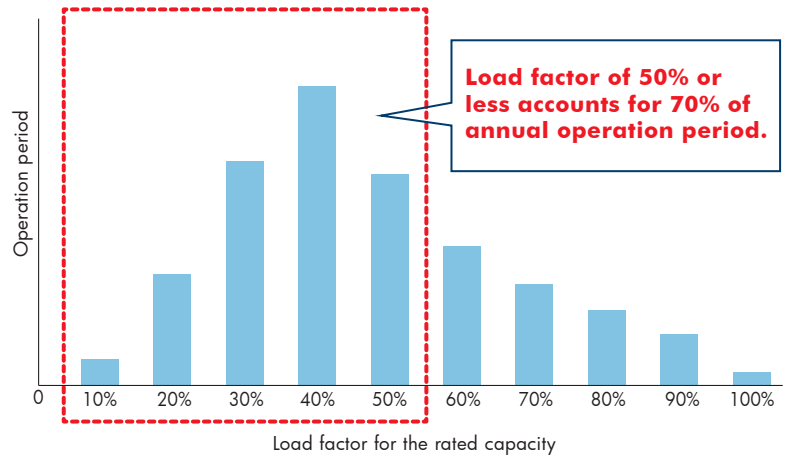

## New scroll compressor\*

### Refrigerant leakage is minimised during low-load operation.

Operation loss due to refrigerant leakage is reduced by the proprietary back pressure control mechanism to ensure stable low-load operation.

Hardware technology

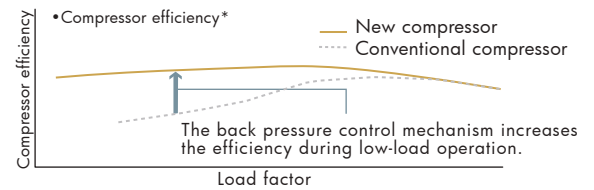

\*Graph shown above is for illustration purposes only.

## Back pressure control mechanism

### Conventional mechanism

The movable scroll is pressed by the pressure difference between high and low pressures. The force pressing the movable scroll decreases during low-load operation, results in compression leakage from movable parts.

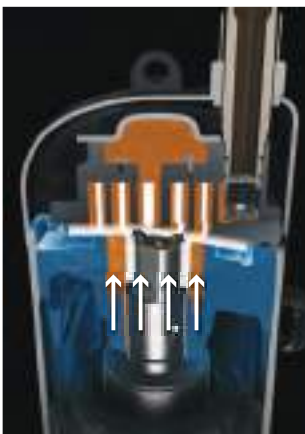

The force pressing the movable scroll decreases during low-load operation.

### New intermediate pressure mechanism

The force pressing the movable scroll is optimised according to operating conditions. The behaviour of the movable scroll has been stabilised to increase efficiency during low-load operation.

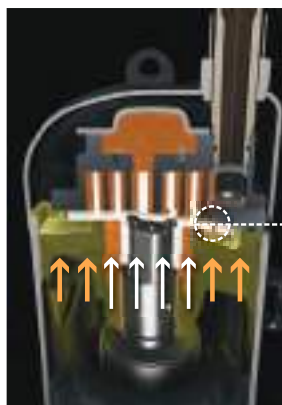

The intermediate pressure keeps pressing the movable scroll during low-load operation.



### Intermediate pressure adjustment port

The intermediate pressure (back pressure) optimises the force pressing the movable scroll depending on the operating condition.

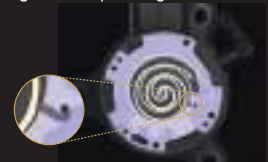



## Energy saving

## VRV+VRT+VAV

Uniting advanced software and hardware technologies for greater energy savings during actual operation.

VRT Smart Control (Fully Automatic Energy-saving Refrigerant Control)

Software technology

### Optimally supply only for the needed capacity of indoor units

Daikin developed VRT smart control by combining air volume control (VAV: Variable Air Volume) for indoor units with conventional VRT control, which optimises compressor speed by calculating the required load for the entire system and optimal target refrigerant temperature based on data sent from each indoor unit. Coordination with the air volume control reduces compressor load and minimises operation loss based on detailed control. VRT smart control ensures energy savings and comfortable air conditioning to meet actual operating conditions.

- Overview of the control (system control flow)

Different automatic energy-saving refrigerant control applies depending on the indoor units connected.

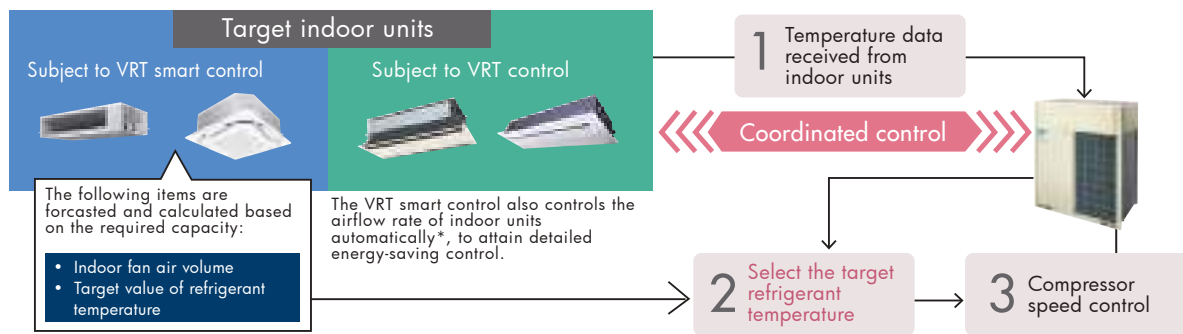

The smooth control (which keeps the compressor running) saves energy and ensures comfort during low-load operation.

- Changes in the air-conditioned room temperature during low-load operation\*

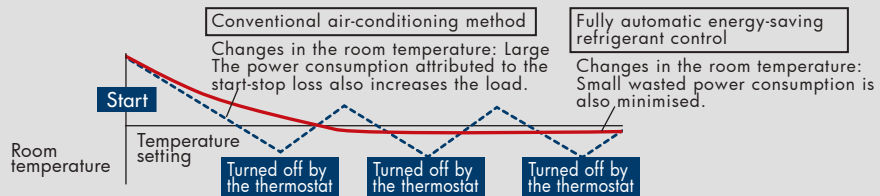

\*Graph shown above is for illustration purpose only.

Note:

- For the classification of indoor units (VRT smart control and VRT control), refer to page 20.
- In case system is having both VRT Control and VRT Smart Control types of Indoor units, system will operate under VRT Control.
- If a system has air handling unit or outdoor-air processing type indoor units, VRT smart control and VRT control are disabled.

## Higher efficiency is provided during rated operation

COP at 100% operation load

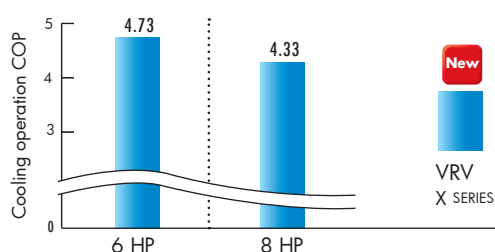

Cooling operation conditions: Indoor temp, of 27°CDB, 19°CWB and outdoor temp, of 35°CDB.

## Advanced oil temperature control

### Standby power consumption is reduced

The advanced oil temperature control reduces standby power consumption compared to conventional models. Standby power is needed for preheating refrigerator oil, which consumes substantial standby power and is reduced to save energy when the air conditioner is stopped.

# VRT - VARIABLE REFRIGERANT TEMPERATURE

## State-of-the-art energy saving technology for VRV system

### Customise your VRV system for optimal annual efficiency

The new VRV X system features VRT technology. VRT automatically adjusts refrigerant temperature to individual building and climate requirement, thus further improving annual energy efficiency and maintaining comfort.

With this excellent technology, running costs are reduced.

How is energy reduced?

During cooling, the refrigerant evaporating temperature ( $T_e$ ) is raised to minimise the difference with the condensing temperature.

During heating, the condensing temperature ( $T_c$ ) is lowered to minimise the difference to the evaporating temperature. Compressors work less and this reduces power consumption.

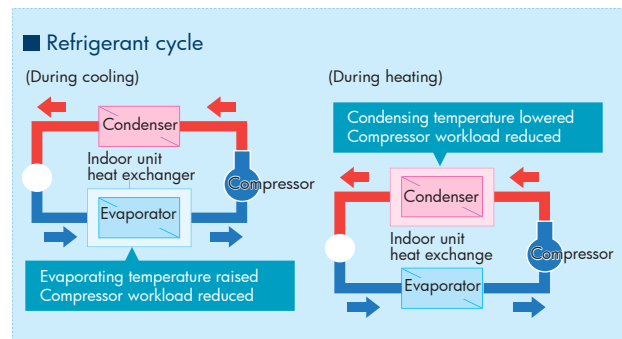

Typical changes in evaporating temperature and COP depending on changing indoor load

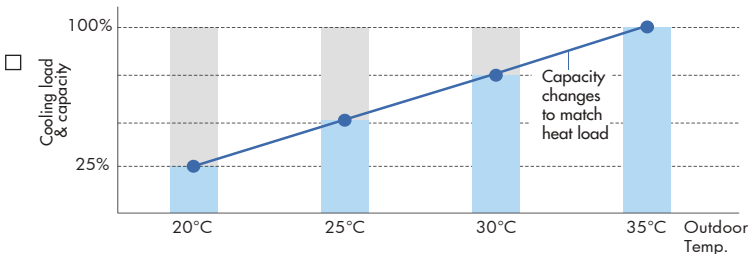

Required capacity changes as air conditioning load changes according to outdoor temperature.

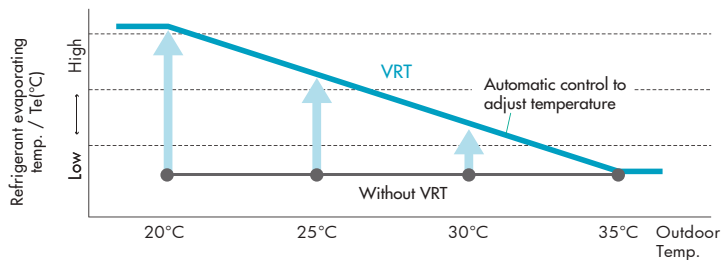

In case of fixed evaporating temperature, excessive cooling, thermo on-off loss and other inefficiencies that occur.

Automatic control adjusts evaporating temperature to heat load change.

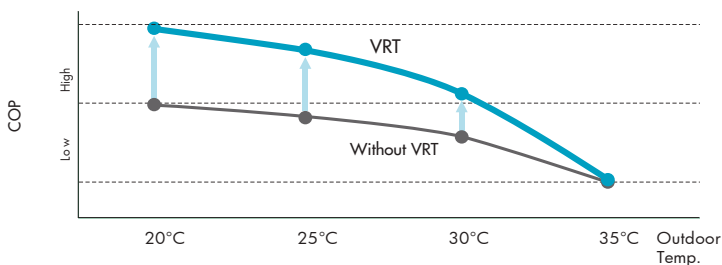

Energy efficiency is improved without sacrificing comfort.

## Fine control to match user preference available through mode selection

Basic mode is selected to maintain optimal comfort.

VRT is selected to save energy and prevent excessive cooling or heating.

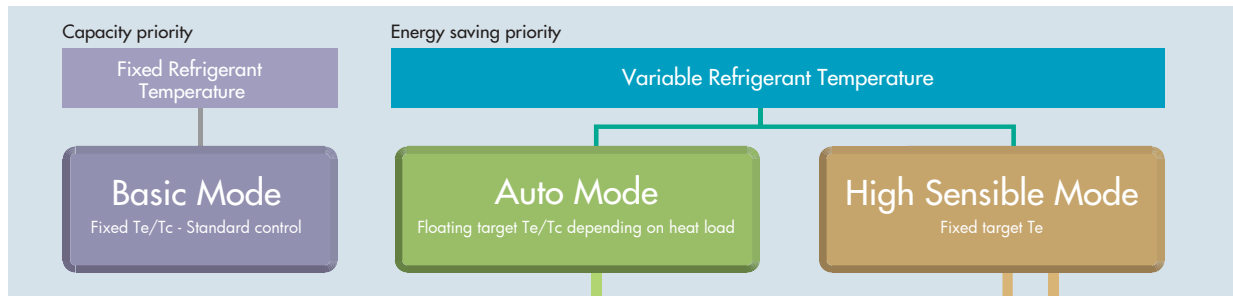

Selecting VRT enables operation to be optimised for either energy efficiency or rapid cooling/heating.

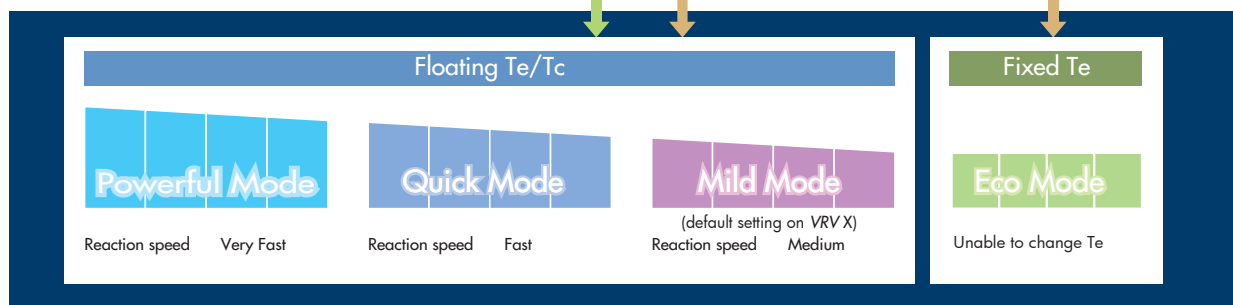

VRT offers quicker cool down to shorten uncomfortable pull down time.

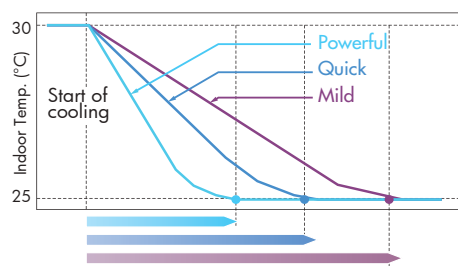

<b>Powerful mode</b>	The refrigerant temperature can go low in cooling (high in heating) than the set minimum (maximum in heating). Gives priority to very fast reaction speed. The refrigerant temperature goes down (or up in heating) fast to keep the room setpoint stable.
<b>Quick mode</b>	Gives priority to fast reaction speed. The refrigerant temperature goes down (or up in heating) fast to keep the room setpoint stable.
<b>Mild mode</b>	Gives priority to efficiency. The refrigerant temperature goes down (or up in heating) gradually, giving priority to the efficiency of the system instead of the reaction speed.

## Recommended for use in these situations

Cooling only regions having differences in daily temperature.

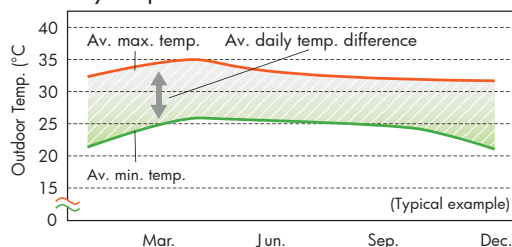

VRT is particularly effective at night when temperatures are low.

Cooling/heating regions having periods of mild outdoor temperatures.

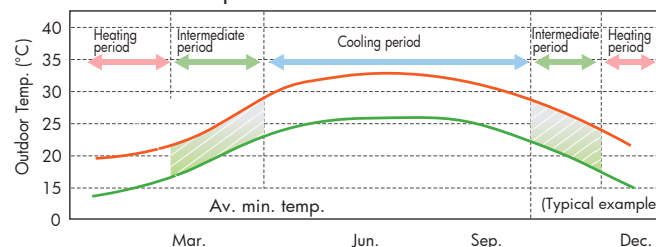

VRT is particularly effective during the intermediate periods.

## Large capacity all DC inverter compressor in compact casing

Large capacity inverter compressor using high tensile strength material, realise 12 HP compressor using 8 HP casing.

### Compact & high efficiency concentrated winding motor

Distributed winding motor  
(Current 8 HP compressor)



Concentrated winding motor  
(New 12 HP compressor)

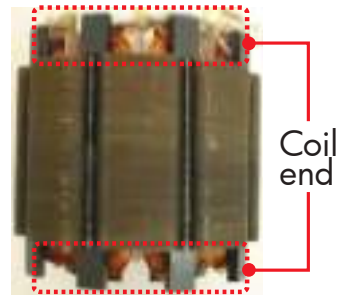

Small size coil end using concentrated winding, reduces copper loss(winding resistance).  
Improves motor efficiency in low rpm range (improves intermediate efficiency).

## Highly integrated heat exchanger

Improves performance by increasing heat exchanger area while maintaining the same installation space.

**Conventional**

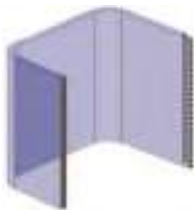

Fine Louvre Fin

**VRV X**



Waffle Fin

Realises highly integrated heat exchanger performance by employing 3 rows and reduced fin pitch coil as well as reduction in airflow resistance by adopting small pipe size design.

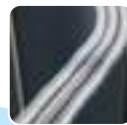

**20 HP**

3 rows with small pipe design,  
increase heat transfer efficiency



## ● 4D Inverter Technology ●

### Improved reliability by introducing Daikin 3-phase capacitor-less 4D Inverter technology

4Ds mean...

- **D**irect Inverter
- **D**ynamic
- **D**rive
- High Energy **D**ensity

- **D**irect conversion circuit which eliminates the electrolytic capacitor and minimise the reactor size
- **D**ynamic waveform control that suppresses the resonance phenomenon generated by miniaturizing parts
- **D**rive technology
- High **D**ensity integration of parts on small printed circuit board

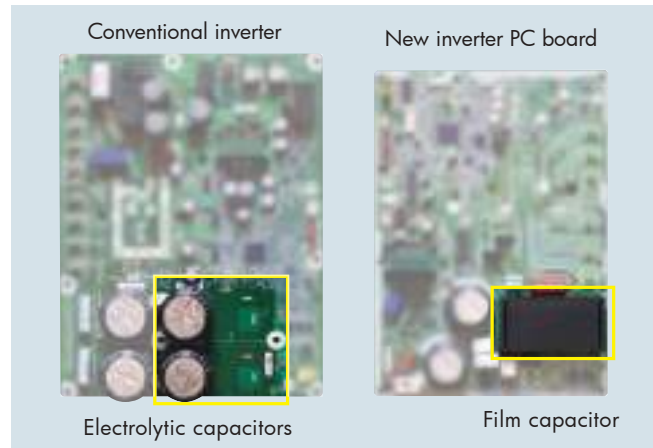

### New Inverter PC Board

The control functions of inverter technology have been integrated on printed circuit boards. As well as improving reliability, this has reduced the number of parts and enabled downsizing.

- New waveform control improves tolerance of variations in power supply voltage. Even if the power supply has irregularities, rises in current are suppressed and operation continues.
- Durability of the inverter printed circuit board improved by changing the electrolytic capacitors for the compressor to film capacitors.

## ● Excellent Performance ●

### Various advanced control main PC board

#### SMT\* packaging technology

SMT packaging technology adopted by the whole computer control panel improve the anti-clutter performance.

Protects your computer board from adverse effect of sandy and humid weather.

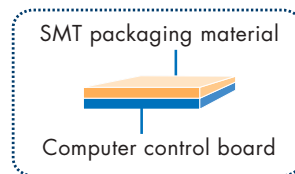

\*SMT: Surface mounted technology

#### Computer control board surface adopting SMT packaging technology



### Improved inner design to increase smooth airflow

Downsizes electric component, relocates to dead space of bell mouth side to decrease airflow resistance.

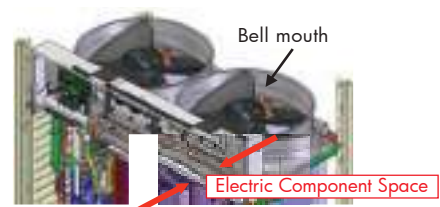

# ADVANCE TECHNOLOGY ACHIEVED

## Excellent Performance

**VRV X**



**Refrigerant cooling technology, ensures stability of PCB temperature**

**Improves reliability at high ambient temperature**

It is possible to cool the inverter power module stability even at high ambient temperature. This helps to keep air conditioning capacity and also ensures efficient and reliable operation.

## Comfort

### Lower operation sound

Improves heat exchanger efficiency, helps to reduce operation sound.

Large airflow, high static pressure and quiet technology.

Without increasing operation sound, advanced analytic technologies are utilised to optimise fan design, increase airflow rate and external static pressure.

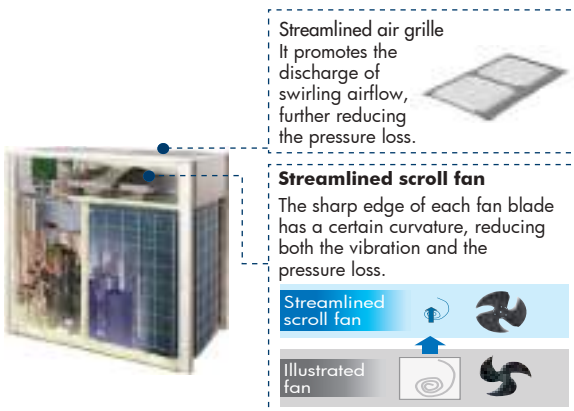

Sound level (dBA)

	6 HP	8 HP	10 HP	12 HP
VRV X	56	56	57	59

### Quiet night-time operation function

Outdoor PCB automatically memorises the time when the peak outdoor temperature appears. It enables quiet operation mode after 8 h\*1 and returns to normal mode after it keeps this on for 9 h\*2.

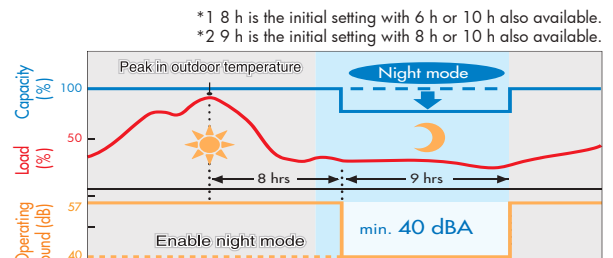

Notes:

- This function is available in field setting.
- The operating sound in quiet operation mode is the actual value measured by Daikin.
- The relationship of outdoor temperature (load) and time shown above is just an example.
- For 10 HP ODU.

## Ease of Maintenance

VRV X series provides a maintenance feature\* which allows the shut down of indoor unit without shutting down the whole VRV system. This feature comes in handy during maintenance period as the remaining indoor units continue to operate.

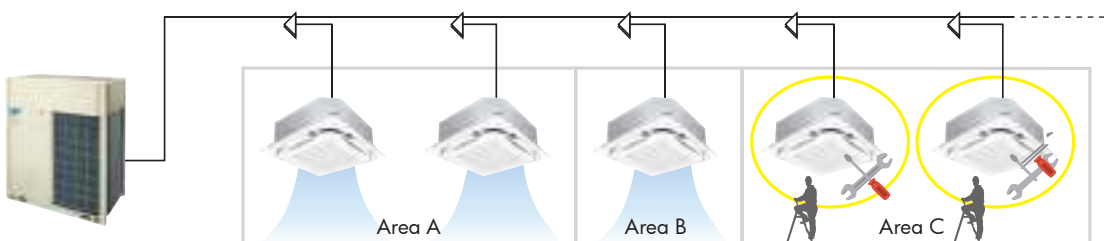

\* Field setting is required.  
This feature does not apply to residential indoor unit connection.  
For more information, please contact Daikin sales office.



## Automatic Refrigerant Charge Function

Contribute to optimised operation efficiency, higher quality and easier installation

### Optimised operation efficiency

The automatic refrigerant charge function automatically determines the optimal amount of refrigerant to be charged.

This function prevents a capacity shortage or energy loss due to excessive or insufficient refrigerant.

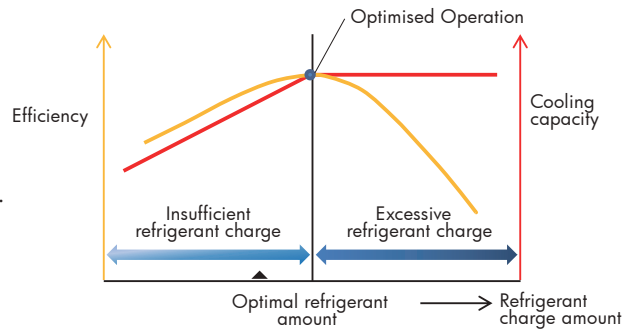

### Higher quality and easier installation

The automatic refrigerant charge function automates the charging of the proper refrigerant amount and the closing of shut-off valves with just one press of the switch after pre-charging. Simplified installation eliminates excessive and insufficient refrigerant charge amounts due to calculation mistakes and this has led to higher installation quality.

#### Conventional

- 1 Calculate necessary refrigerant amount from design drawing
- 2 Recalculate refrigerant amount from final installation drawing
- 3 Charge refrigerant
- 4 Regularly check refrigerant weight on weighing scale
- 5 Complete by manually closing valves when proper weight is reached



- 1 Calculation of necessary refrigerant amount from design drawing
- 2 Pre-charge of refrigerant\*
- 3 Start of automatic refrigerant charge operation

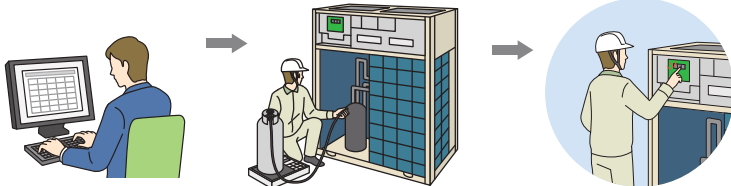

Automatic completion with optimal refrigerant amount

Monitoring refrigerant charging is not required

No recalculation of charge amounts due to minor design changes at site

\*Pre-charge amount changes according to conditions, and there are cases when pre-charging is unnecessary.

## Multiple advanced features ensuring more accurate test operation and stable system

### Efficient automatic test operation

Automatically checks the wirings between outdoor units and indoor units to confirm whether there is a defective wiring.

### Confirms and corrects the actual piping length.

Automatically checks whether the stop valve in each outdoor unit is in normal status to ensure the smooth operation of air conditioning system.

### Free phase technology

Phase reversal occurs in areas where power supply is frequent. At the time of power recovery, phase reversal may take place due to AC source and device may stop for PCB protection. By employing Free Phase technology, continued operation is achieved.

#### Automatic check



Wiring check

Piping check

Stop valve check

## Simplified commissioning and after-sales service

### Function of information display by luminous digital tube

VRV X system utilises the 7-segment luminous digital tubes to display system operation information, enabling the operational state to be visually displayed whilst facilitating simplified commissioning and after-sales service.

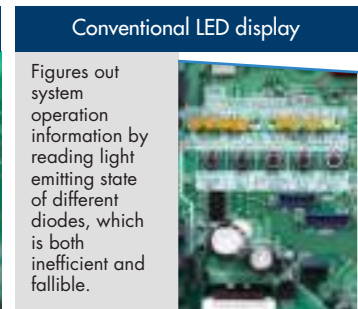
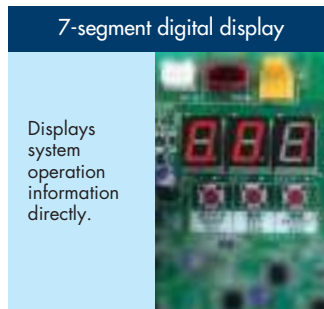

### VRV configurator

- The VRV configurator is an advanced solution that allows for easy system configuration and commissioning.
- Less time is required on the roof configuring the outdoor unit.
- Multiple system at different sites can be managed in exactly the same way, thus offering simplified commissioning for key accounts.
- Initial setting on the outdoor unit can be easily retrieved.

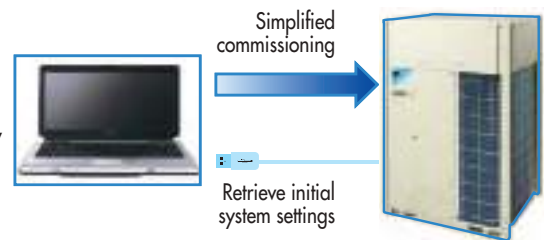

## Outdoor unit sequencing technology

### Automatic sequencing operation

During start-up, the Daikin VRV X unit sequencing operation will be automatically enabled to ensure balanced operation of each outdoor unit to improve longevity of equipment and stable operation.

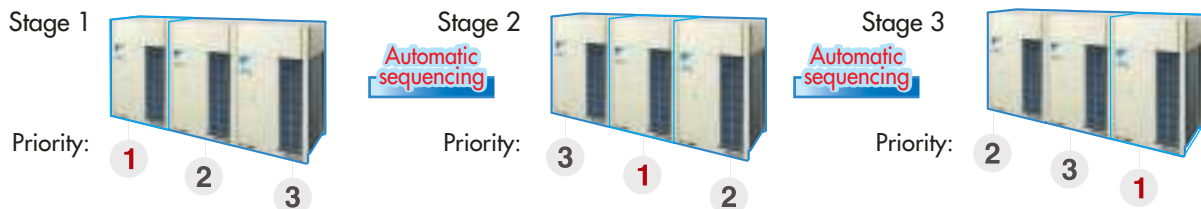

## Double back-up operation functions responding resiliently to various unexpected situations

### Double back-up operation functions

Daikin VRV X system boasts double back-up operation functions, which can secure the use of air conditioners in this area to the greatest extent by emergently enabling double back-up operation functions even if failure occurs in a set of air conditioning equipment. In the event of a failure, emergency operation can be enabled conveniently to allow the remaining system to operate in a limited fashion.

#### Compressor back-up Operation Function

If malfunction occurs in a compressor...

Emergency operation can be easily set and enabled by the outdoor unit (for a single outdoor unit system RXQ16-20ARY6 : for Cooling only model RXYQ14-20ARY6: for Heat Pump model).

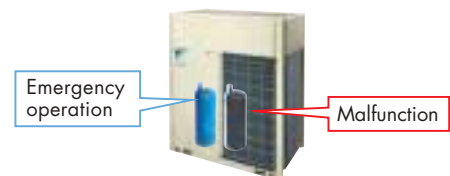

#### Unit back-up operation function

If malfunction occurs in an outdoor unit, emergency operation can be conveniently set and enabled by the remote controller for indoor unit (for systems composed of two or more outdoor units).



## More options for installation location

### Long piping length

The long piping length provides more design flexibility, which can match even large-sized buildings.

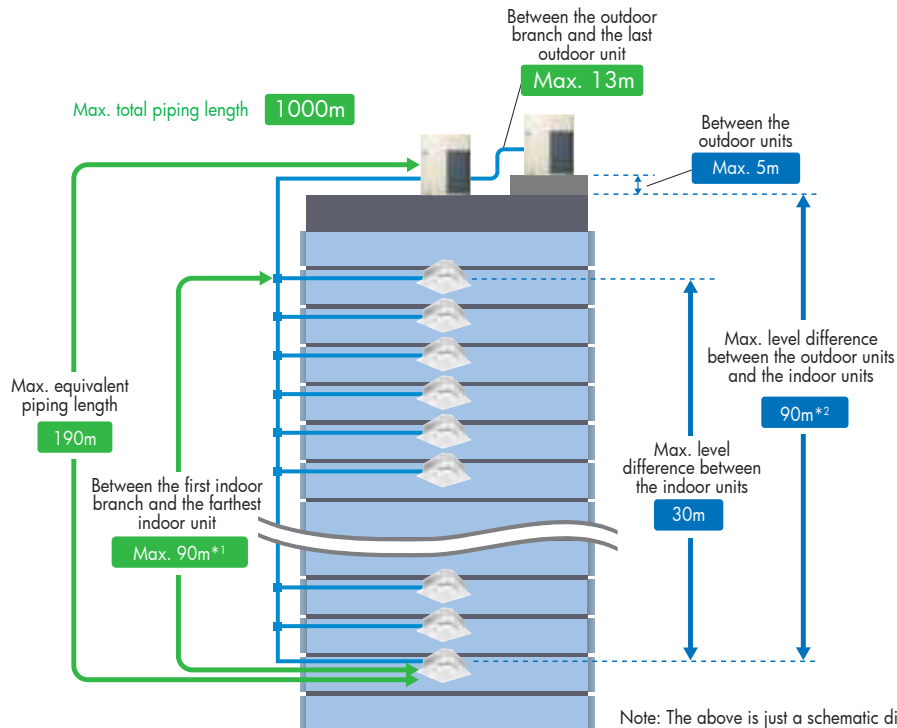

Maximum allowable piping length	Actual piping length (Equivalent)	165 m (190 m)
	Total piping length	1000 m
	Between the first indoor branch and the farthest indoor unit	90 m*1
Maximum allowable level difference	Between the outdoor branch and the last outdoor unit (Equivalent)	10 m (13 m)
	Between the outdoor units (Multiple use)	5 m
	Between the indoor units	30 m
	Between the outdoor units and the indoor units	90m*2

1. No special requirements up to 40 m. The maximum actual piping length can be 90 m, depending on conditions. Various conditions and requirements have to be met to allow utilisation of 90 m piping length.
2. When level differences are 50 m or more, the diameter of the main liquid piping size must be increased. If the outdoor unit is above the indoor unit, a dedicated setting on the outdoor unit is required.

### Connection ratio

Connection capacity at maximum is 200%.

Connection ratio  
50%–200%

$$\text{Connection ratio} = \frac{\text{Total capacity index of the indoor units}}{\text{Capacity index of the outdoor units}}$$

Conditions of VRV indoor unit connection capacity

Applicable VRV indoor units	FXDQ, FXMQ-PB, FXAQ, models	Other VRV indoor unit models*1
Single outdoor units	<b>200%</b>	200%
Double outdoor units		160%
Triple outdoor units		130%

\*1 For the FXFQ25 and FXVQ models, maximum connection ratio is 130% for the entire range of outdoor units.

Note: If the operational capacity of indoor units is more than 130%, low airflow operation is enforced in all the indoor units.

\*Refer to page 65 for outdoor unit combination details.



## High external static pressure

VRV X outdoor unit has achieved high external static pressure up to 78.4 Pa, ensuring the efficient heat dissipation and stable operation of equipment in either hierarchical or intensive arrangement.

**78.4 Pa**

- More options in the opening/angle of louvre
- Outstanding heat dissipation effect in both hierarchical and intensive arrangement

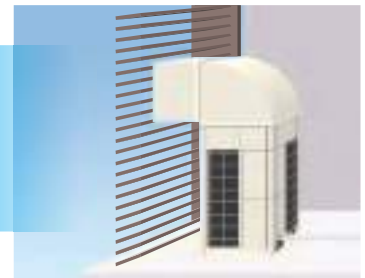

## Outdoor Units

### The outdoor unit capacity is up to 60 HP in increment of 2 HP.

- VRV X outdoor unit offers a higher capacity of up to 60 HP, responding to the needs of large-sized buildings.
- The single outdoor unit has only 2 different shapes and dimensions, not only simplifying the design process, but also bringing the system flexibility to a new level.
- With the outdoor unit capacity increased in increment of 2 HP, customers' needs can be precisely met.

### Standard Type

#### • Single Outdoor Units

6, 8, 10, 12 HP



RX(Y)Q6ARY6  
RX(Y)Q8ARY6  
RX(Y)Q10ARY6  
RX(Y)Q12ARY6

14, 16 HP



RX(Y)Q14ARY6  
RX(Y)Q16ARY6

18, 20 HP



RX(Y)Q18ARY6  
RX(Y)Q20ARY6

#### • Double Outdoor Units

22, 24 HP



RX(Y)Q22ARY6  
RX(Y)Q24ARY6

26, 28, 30 HP



RX(Y)Q26ARY6  
RX(Y)Q28ARY6  
RX(Y)Q30ARY6

#### • Double Outdoor Units

32, 34, 36, 38, 40 HP



RX(Y)Q32ARY6  
RX(Y)Q34ARY6  
RX(Y)Q36ARY6  
RX(Y)Q38ARY6  
RX(Y)Q40ARY6

#### • Triple Outdoor Units

42, 44, 46, 48, 50, 52 HP



RX(Y)Q42ARY6  
RX(Y)Q44ARY6  
RX(Y)Q46ARY6  
RX(Y)Q48ARY6  
RX(Y)Q50ARY6  
RX(Y)Q52ARY6

54, 56, 58, 60 HP



RX(Y)Q54ARY6  
RX(Y)Q56ARY6  
RX(Y)Q58ARY6  
RX(Y)Q60ARY6

### Line-up

HP	6	8	10	12	14	16	18	20	22	24	26	28	30	32	34	36	38	40	42	44	46	48	50	52	54	56	58	60
Cooling Only/ Heat Pump	●	●	●	●	●	●	●	●	●	●	●	●	●	●	●	●	●	●	●	●	●	●	●	●	●	●	●	●





































# INDOOR UNIT LINE-UP

## Enhanced Range Of Choices

A variety of VRV indoor units is enabled in one system, opening the door to stylish and quiet indoor units.

### VRV Indoor Units

17 types 76 models

Type	Model Name	Capacity Range Capacity Index	0.8 HP	1 HP	1.25 HP	1.6 HP	2 HP	2.5 HP	3 HP	3.2 HP	4 HP	5 HP	6 HP	7 HP	8 HP	10 HP	16 HP	20 HP
			20	25	32	40	50	63	71	80	100	125	140	170	200	250	400	500
Ceiling Mounted Cassette Round Flow & Round Flow with Sensing (Optional)	 VRT FXFSQ-ARV16 <b>VRT Smart Control</b>			●	●	●	●	●		●	●	●	●					
Ceiling Mounted Cassette (Compact Multi Flow)	 VRT FXZQ-AVM <b>VRT Smart Control</b>		●	●	●	●	●											
Ceiling Mounted Cassette (Double Flow)	 VRT FXCQ-AVM			●	●	●	●	●		●		●						
Ceiling Mounted Cassette Corner	 New FXKQ-AV				●	●	●	●										
Slim Ceiling Mounted Duct	 VRT FXDQ-PDV36 (with drain pump) <b>VRT Smart Control</b>	 (700mm width type)	●	●	●													
	 VRT FXDQ-NDV36 (with drain pump) <b>VRT Smart Control</b>	 (900/1,100mm width type)				●	●	●										
Ceiling Mounted Duct	 VRT FXMQ-PAVE/PBV36 <b>VRT Smart Control</b>		●	●	●	●	●	●		●	●	●	●					
	 VRT FXMQ-NVE													●	●	●		
Mid Static Ceiling Mounted Duct	 VRT FXMQ-ARV16					●	●	●		●	●							
	 VRT																	
Ceiling Suspended	 VRT FXHQ-MAVE				●			●			●							
4-Way Flow Ceiling Suspended	 VRT FXUQ-AVEB								●		●							
Wall Mounted	 VRT FXAQ-ARVE6 <b>VRT Smart Control</b>		●	●	●	●	●	●										
Floor Standing	 VRT FXLQ-MAVE				●		●	●										
Concealed Floor Standing	 VRT FXNQ-MAVE				●		●	●										
Multi Cube/Spot	 New FXPQ-AVM			●														
Floor Standing Duct	 VRT FXVQ-NY1(6)											●			●	●	●	●
Clean Room Air Conditioner	 VRT FXBQ-PVE					●	●	●										
	 VRT FXBPQ-PVE							●										

At Daikin, we offer a wide range of indoor units, including both VRV and residential models, responding to a variety of needs of our customers that require air conditioning solutions.

## VRV Indoor Units

Ceiling Mounted Cassette  
Round Flow & Round Flow  
with Sensing (Optional)

FXFSQ-ARV16



Presence of people and floor temperature can be detected to provide comfort and energy savings.



Ceiling Mounted Cassette  
(Compact Multi Flow) Type

FXZQ-AVM

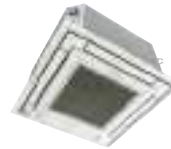

Quiet, compact and designed for users comfort.



Ceiling Mounted Cassette  
(Double Flow) Type

FXCQ-AVM



Add finishing touch to your ceiling, with enhancing function and design.



Ceiling Mounted Cassette  
Corner Type

FXKQ-AV

**New**



Slim design for flexible installation.



Slim Ceiling Mounted  
Duct Type

FXDQ-PDV36



FXDQ-NDV36



Slim design, quietness and static pressure switching.



Ceiling Mounted Duct Type

FXMQ-PBV36



FXMQ-ARV16

FXMQ-NVE



High/Mid external static pressure allows flexible installations.



4-Way Flow Ceiling  
Suspended Type

FXUQ-AVEB



This slim and stylish indoor unit achieves optimum air distribution, and can be installed without the need for ceiling cavity.



Ceiling Suspended Type

FXHQ-MAVE



Slim body with quiet and wide airflow.



# INDOOR UNIT LINE-UP

## Floor Standing Duct Type

FXVQ-NY16  
(High static pressure type)



Large airflow type for large spaces.  
Flexible interior design for each tenant.



## Floor Standing Type

FXLQ-MAVE



## Concealed Floor Standing Type

FXNQ-MAVE



Suitable for perimeter zone air conditioning.



## Wall Mounted Type

FXAQ-ARVE6



Stylish flat panel design harmonised with your interior décor.



## Clean Room Air Conditioner

FXBQ-PVE

FXBPQ-PVE

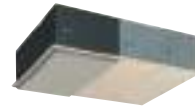

Suitable for hospitals and other clean spaces.



## Multi Cube (Spot AC) Type

FXPQ-AVM

New



New solution in large space comfort.



# VRV Indoor Units

## Ceiling Mounted Cassette Round Flow & Round Flow with Sensing (Optional)

FXFSQ25A / FXFSQ32A / FXFSQ40A /  
FXFSQ50A / FXFSQ63A / FXFSQ80A /  
FXFSQ100A / FXFSQ125A /  
FXFSQ140A

VRT Smart Control



Round flow  
with sensing  
(Optional)

Presence of people and floor temperature can be detected to provide comfort and energy savings.

### Dual sensors\*1

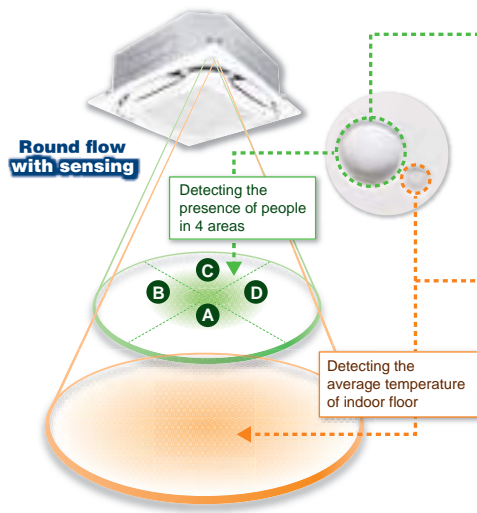

#### Infrared presence sensor

The 4 sensors detect human presence.

Ceiling height	2.7m	3.5m	4.0m
Detection range (diameter) <sup>*3</sup>	approx. 8.5m	approx. 11.5m	approx. 13.5m

\*3. The infrared presence sensor detects 80 cm above the floor.

#### Infrared floor sensor

The sensor detects the floor temperature and automatically adjusts operation of the indoor unit to reduce the temperature difference between the ceiling and the floor.

Ceiling height	2.7m	3.5m	4.0m
Detection range (diameter) <sup>*4</sup>	approx. 11m	approx. 14m	approx. 16m

\*4. The infrared floor sensor detects at the floor surface.

### Various sensing functions

#### Sensing sensor mode<sup>\*5\*6</sup>

Sensing sensor low mode (default: OFF)

When there are no people in a room, the set temperature is shifted automatically.

The system automatically saves energy by detecting whether or not the room is occupied. The set temperature is shifted automatically if the room is unoccupied.

Example • Cooling setpoint: 26°C • Shift temperature: 1.0°C  
• Shift time: 30 min. • Limit cooling temperature: 30°C

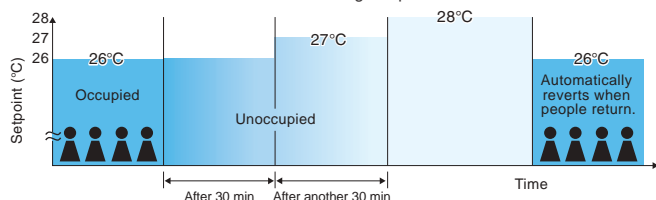

If people do not return, the air conditioner will raise the temperature 1°C every 30 minutes and then operate at 30°C.

Operation is reduced in places where there are no people.

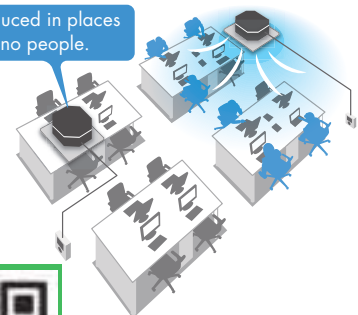

For More information  
'Scan Me'

Shift temperature and time can be selected from 0.5 to 4°C in 0.5°C increments and 15, 30, 45, 60, 90 or 120 minutes respectively with remote controller.

\*1. Applicable when sensing panel (BYCQ140EEF6/BYCQ125EEK) is installed.

\*5. These functions are not available when using the group control system.

\*6. User can set these functions with remote controller.

## VRV Indoor Units

### Sensing sensor stop mode (default: OFF)

When there are no people in a room, the system stops automatically.\*7

The system automatically saves energy by detecting whether or not the room is occupied.

Based on preset user conditions, the system automatically stops operation if the room is unoccupied.

Absent stop time can be selected from 1 to 24 hrs in 1 hr increments with remote controller.

\*7. Please note that upon re-entering the room, air conditioner will not switch on automatically.

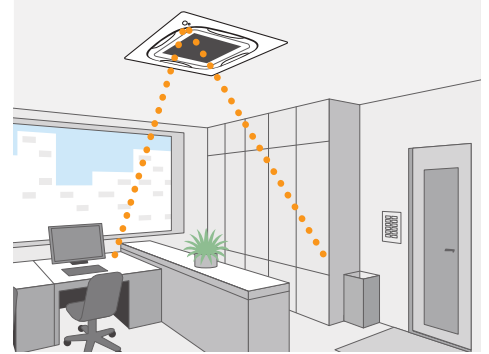

### Auto airflow function\*8

\*8. Airflow direction should be set to "Auto".

**New** Direct Airflow (default: OFF)

Cooling

Dry

When human presence is not detected

When human presence is detected

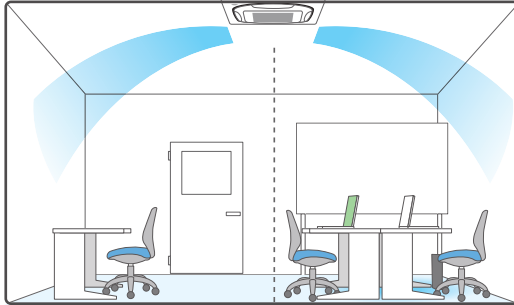

Optimal air direction by "Auto"

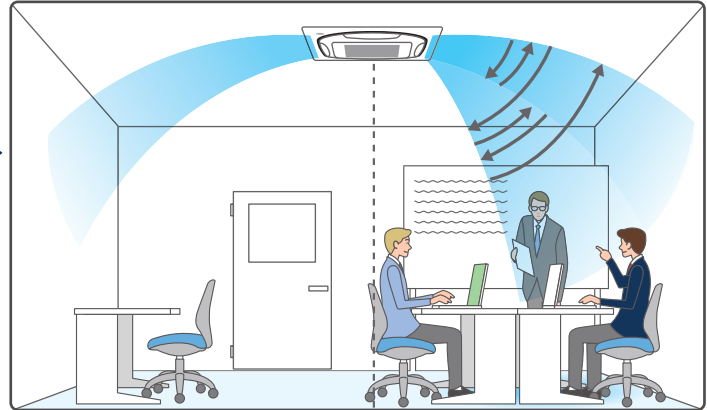

Optimal air direction by "Auto"

Swing (narrow)

- With Auto airflow direction mode, flaps are controlled to deliver optimal airflow when the room is unoccupied.



- When human is detected, air direction is set to "Swing (narrow)" to deliver cool air to users.

## Comfort and energy saving preventing over cooling\*9

\*9. Airflow direction and airflow rate should be set to "Auto".

### Floor temperature is detected and over cooling prevented.

Cooling

Without sensing function

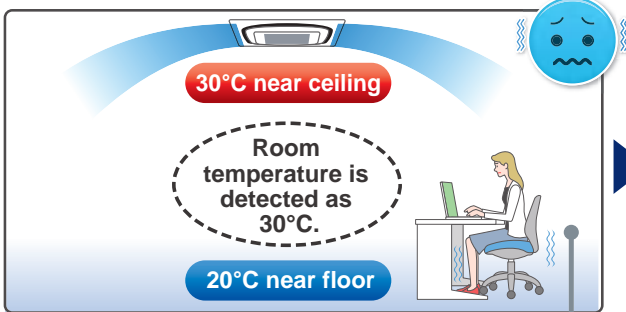

Area around feet gets too cold because air conditioner continues until the temperature near the ceiling reaches the set temperature.

With sensing function

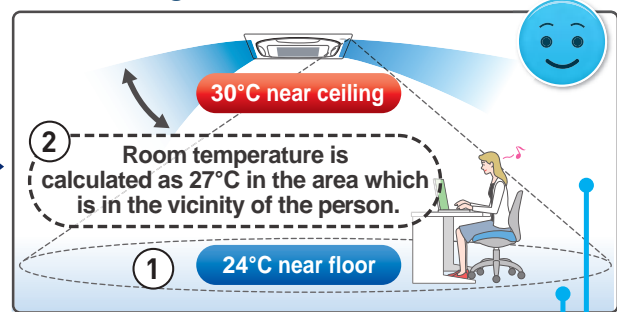

The floor temperature, which is lower than near the ceiling, is detected.

Automatic control using the temperature near the person as the room temperature.

Energy savings

The temperature near the person is automatically calculated by detecting the temperature of the floor. Energy is saved, because the area around the feet does not get too cold.

### New Circulation Airflow



The illustration shows typical airflow. Effectiveness may differ according to room conditions, room size and distance to walls.

### New Direct Airflow

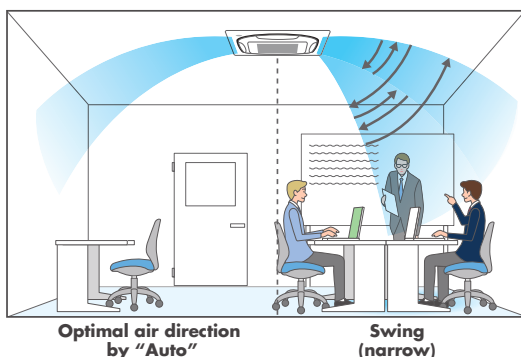

### Individual Airflow Direction Control

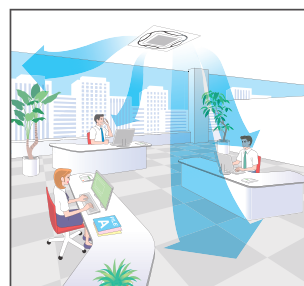

The illustration shows typical airflow.

# INDOOR UNIT LINE-UP

## Circulation Air Flow

\*1. Applicable when wired remote controller BRC1E62 is used.  
\*2. Not applicable when using individual airflow direction control.

Circulation airflow cools the entire room to deliver comfort that never feels cold

During 2-way horizontal flow



Comfort to the entire room with even temperatures and no cold air pockets at floor level

### 4-way cassette (Swing)

**Comparison Conditions**

- Room size: Width 7.5m x depth 7.5m x height 2.6m
- Indoor unit capacity: 71 class
- Outdoor air temperature: 35°C
- Airflow rate and air direction: high / swing

**30.0**  
**29.0**  
**28.0**  
**27.0**  
**26.0**  
**25.0**  
**24.0**  
**23.0**  
**22.0**  
**21.0**  
**20.0**

**Areas at floor level are cold while areas around walls are hot.**

**Approx. 5% energy savings by reducing uneven temperatures**

\*3. Calculated under the following comparison conditions:  
When the average temperature at a height of 0.6m above the floor reaches set temperature. (26°C)

**Full comfort is provided with no cold feet.**

### Circulation Airflow (2-way horizontal + 4-way swing)

## Configurations of Circulation Airflow

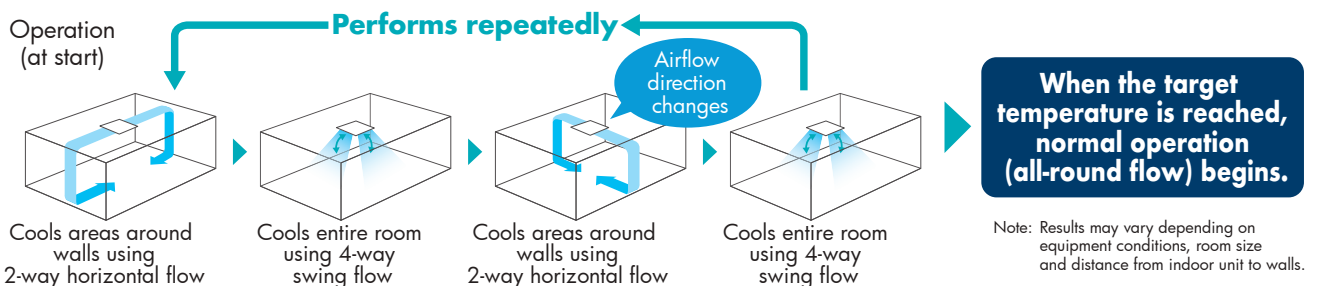

## Three technologies that achieved circulation airflow

Flow-out is straight, horizontally and strong, so the air travels far and even reaches the wall from which it falls to the floor. This approach and technology makes circulation airflow possible.

### 1 Use of new wide flaps (Straight)

Compared to conventional models, the new wide flap increases straightness of the airflow, so coverage is approximately doubled.

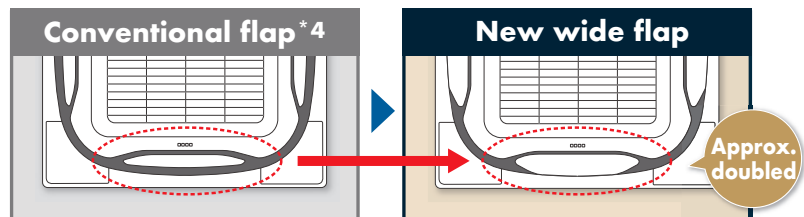

\*4. FXFQ-S model

#### New wide flap construction inhibits ceiling dirt and grime

By tapering both flap ends, the airflow that causes dirty ceilings is directed downward.



### 2 Optimising airflow angle (Horizontally)

Even with the flap angle raised, a sufficient airflow route is maintained to realize a more horizontal airflow angle.

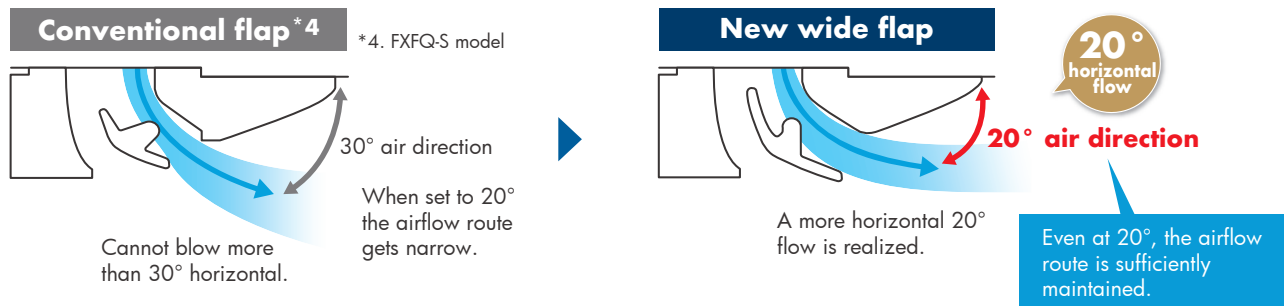

### 3 Increased velocity in 2-way flow (Strongly)

Velocity increased by making 2-way flow. Powerful airflow was realized.

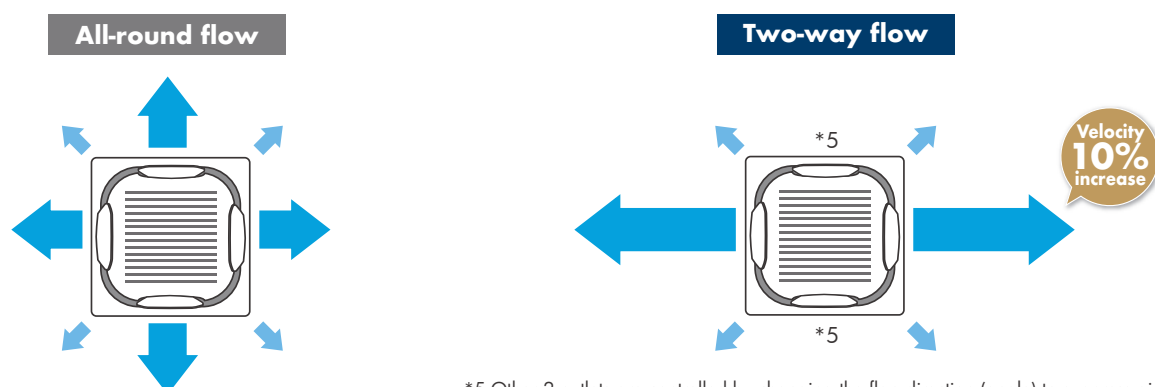

\*5. Other 2 outlets are controlled by changing the flap direction (angle) to suppress airflow volume.

# INDOOR UNIT LINE-UP

\*1. Applicable when wired remote controller BRC1E63 is used.

## Comfortable air conditioning for all room layouts and conditions

Airflow direction can be individually adjusted for each air discharge outlet to deliver optimal air distribution.

### Easy setting is possible with a wired remote controller.



BRC1E63

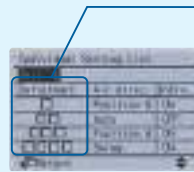

Remote controller screen

There are identification marks near the air outlets.

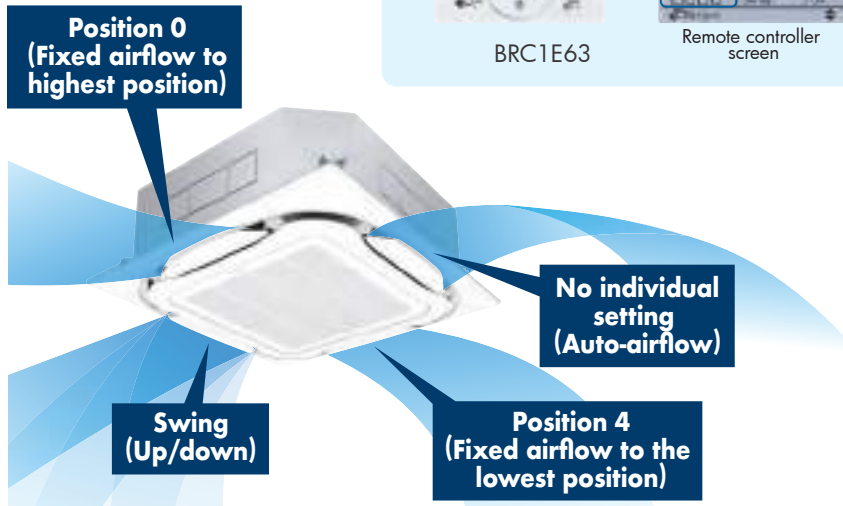
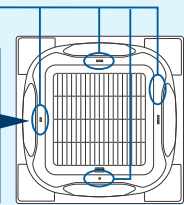

### Individual airflow settings

- No individual setting (Auto airflow)
- Position 0 (Highest point)
- Position 1
- Position 2
- Position 3
- Position 4 (Lowest point)
- Swing

Individual settings are possible as stated above.

## When individual airflow is selected, airflow direction can be adjusted to room layout.

### For offices

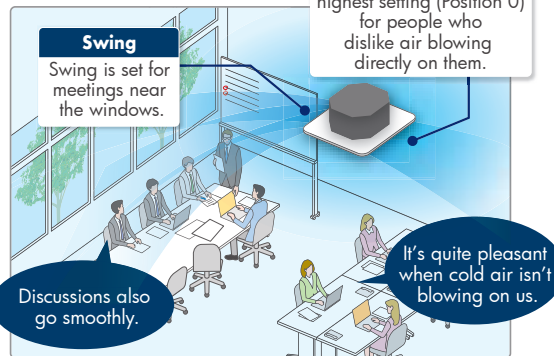
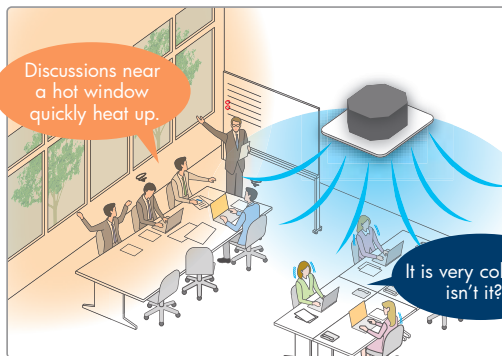

### For shops and restaurant

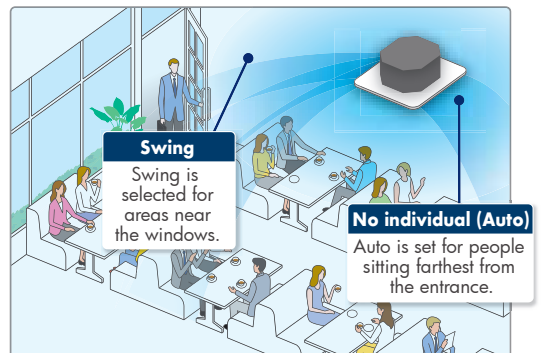
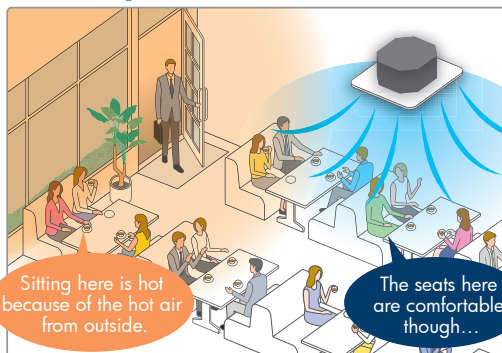

**New** Wide variety of decoration panels (Option)

- Designer choice has been given a boost with the increase in number of new types of decoration panels.



Standard panel with sensing

Designer panel\*2

Standard panel\*2

**New** Designer panel (Option)

## Close to ideal styling

— New designer panel —

FLAT	CLEAN	ROUND
<p>Flatter styling: Suction panel grid texture smoothed.</p> 	<p>Clean-cut form: Soiling is hard to see on smart-looking panel.</p> 	<p>Subtle distinction: Around suction inlets silvering is a tasteful touch.</p> 

Decoration Panel Line-up (Option)



**Standard panel**<sup>1</sup>  
BYCQ125EAF6 (Fresh White)

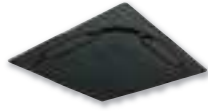

**Standard panel**<sup>1</sup>  
BYCQ125EAK (Black)



**Designer panel**<sup>1</sup>  
BYCQ125EAPF (Fresh White)

\*1. Sensing function is applicable when sensing panel is installed.



**Sensing panel**  
BYCQ140EEF6 (Fresh White)

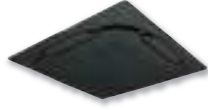

**Sensing panel**  
BYCQ125EEK (Black)

**New** Auto grille panel (Option)\*1

- Clogged filters strain performance of the indoor unit and may result in breakdowns. Impeded airflow through the filter also lowers operational efficiency, which increases electricity bills. With the auto grille, anyone can easily clean the filter, which translates to lower maintenance cost and longer life of the air conditioner.
- With the auto grille panel, motorised raising and lowering allows suction panel and air filter cleaning to be carried out without the need for a step ladder.

A dedicated wireless remote controller is supplied with the auto grille panel.

**For these situations recommended**

- Where the air is dusty and likely to soil the air conditioner.
- Where simple and quick filter and grille cleaning is a worthwhile benefit.



**Auto grille panel**<sup>1</sup>  
BYCQ125EASF (Fresh White)

# INDOOR UNIT LINE-UP

## Comfortable airflow

- Indoor unit offers 360° airflow discharges air in all directions with more uniform temperature distribution.

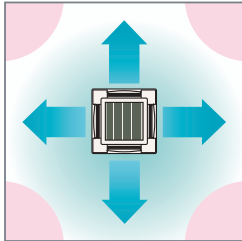

There are areas of uneven temperature.

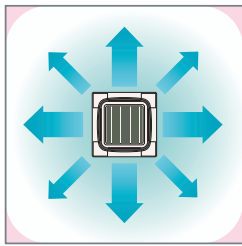
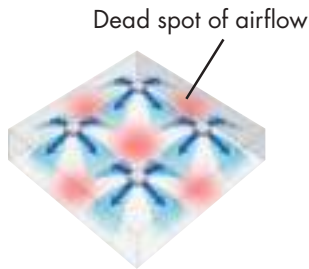

There are much fewer areas of uneven temperature.



## Easy installation

- Drain pump is equipped as a standard accessory with a 850mm lift.

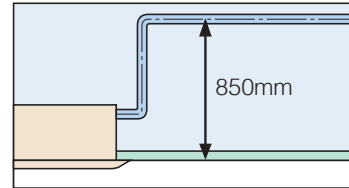

## Easy maintenance

- Internal hygiene can be easily checked without removing the whole panel. Simply opening the suction panel allows the internal drain pan to be checked.

**New**

- 24mm diameter drain outlet

The drain outlet allows insertion of a finger or dental mirror for inspection of the internal cleanliness of the drain pan. Removal of the suction panel enables access.

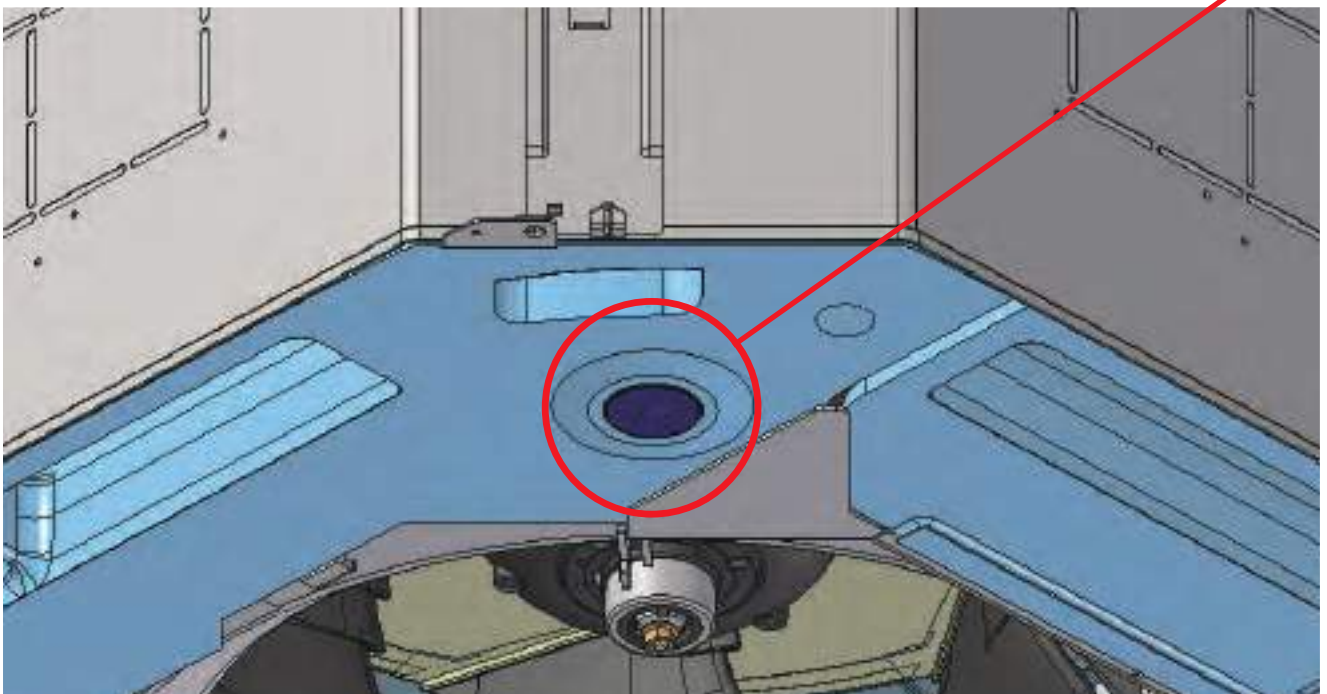

## Example of airflow patterns

All-round flow is available, as well as 2-way to 4-way flows, so you can choose the most suitable airflow pattern depending on location or room layout.

**All-round flow**

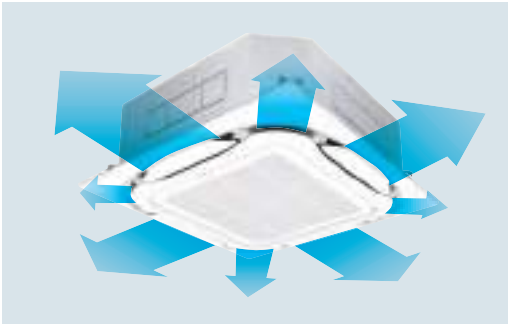

**4-way flow**

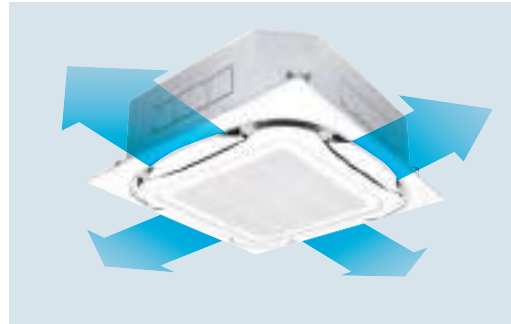

**3-way flow**

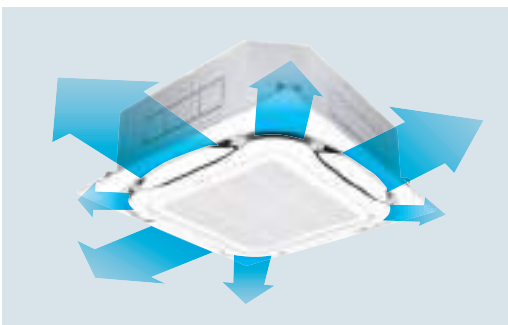

**L-shaped 2-way flow**

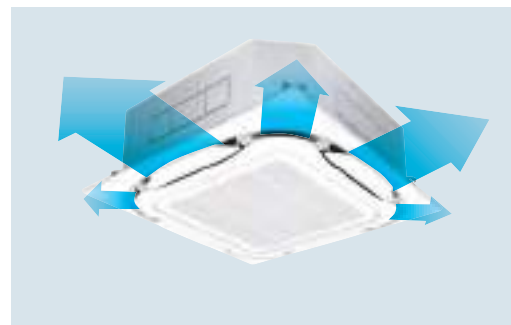

Note: Whatever the discharge direction, the same type of panel is used. If installing for other than all-round flow, an air discharge outlet sealing material (option) must be used to close each unused outlet.

All-round flow is available, as well as 2-way to 4-way flows, so you can choose the most suitable airflow pattern depending on location or room layout.

- An antibacterial treatment that uses silver ions has been applied to the drain pan, preventing the growth of slime, mould and bacteria that cause blockages and odours. (The lifespan of a silver ion cartridge depends on the usage environment, but should be changed once every two to three years.)
- The air filter has an anti-mould and antibacterial treatment that prevents the growth of mould generated from dust or moisture that may adhere to the filter.



**New**

- Control of the airflow rate can be selected from 5-step control and auto.

## VRV Indoor Units

### Ceiling Mounted Cassette (Compact Multi Flow Cassette) Type

**FXZQ20AVM / FXZQ25AVM / FXZQ32AVM  
/ FXZQ40AVM / FXZQ50AVM**

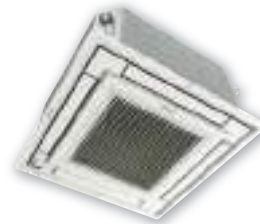

**VRT Smart Control**

\*FXZQ-A

### Quiet, Compact, Designed for user comfort

### Compact & Elegant Design

- Fully-flat integration in standard architectural ceiling tiles, leaving only 8mm.
- Remarkable blend of iconic design and engineering excellence with an elegant finish in white.
- The newly designed panel integrates fully within one ceiling tile enabling lights, speakers and sprinklers to be installed in the adjoining ceiling tiles.

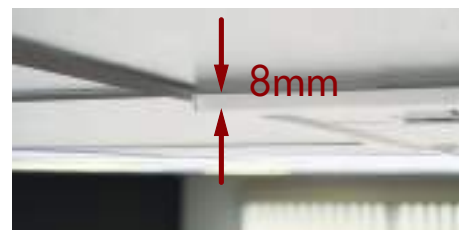

### Efficiency & Comfort

- Two optional intelligent sensors improve energy efficiency and comfort.
- An optional presence and floor sensor kit can be fitted to the cassette for draught prevention, energy-saving operation and to provide optimal control of airflow.



**Individual airflow direction control: Flexibility to suit every room layout without changing the location of the unit.**

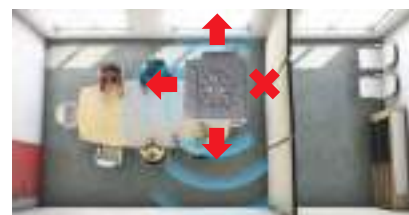

### Auto swing (up/down)

Possibility to select automatic vertical moving of the air discharge flaps for efficient air and temperature distribution throughout the room.

### Ceiling soiling prevention

- Prevents air from blowing against the ceiling to prevent ceiling stains.
- Reduced energy consumption, thanks to the specially developed small tube heat exchanger, DC fan motor, and drain pump optional fresh air intake kit.

## Ceiling Mounted Cassette (Double Flow) Type

**FXCQ25AVM / FXCQ32AVM / FXCQ40AVM /  
FXCQ50AVM / FXCQ63AVM / FXCQ80AVM /  
FXCQ125AVM**



### Add finishing touch to your ceiling, with enhancing function and design.

Stylish unit blends easily with any interior. Integrated ceiling surface with sophisticated panel design with the adoption of flat flap. Add finishing touch to your ceiling, with enhancing function and design.

- Individual airflow direction control (Unavailable during automatic airflow mode, airflow angle: configurable from 0 to 4 swing positions.)

#### Individual flap control

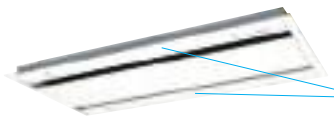

The flat flaps close entirely when the unit is not operating and there are no air intake grilles visible.

- Reduced energy consumption thanks to specially developed small tube heat exchanger, DC fan motor and drain pump.

#### Enhanced functions from various aspects such as maintenance

- Check contamination in drain pan by simply removing suction grille and panel.
- The flap parts are easy to clean because it is hard to condensate and get dirty.
- Equipped with long life filter which requires only 1-year maintenance interval.
- Adjuster pockets mount at four corners of the unit enable to adjust the main unit without removing the panel.
- Drain pump is equipped as standard accessory with 850mm lift.

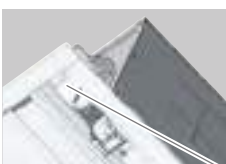

Adjuster Pocket

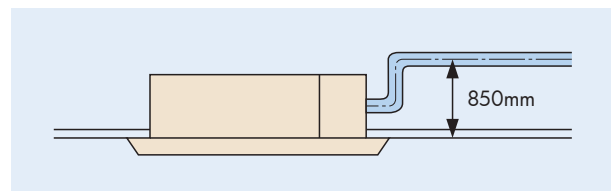

- An antibacterial treatment that uses silver ions has been applied to the drain pan, preventing the growth of slime, mould and bacteria that cause blockages and odours.

(The lifespan of a silver ion cartridge depends on the usage environment, but should be changed once every two to three years.)



Drain socket part

- Easy visual inspection of drainage through the transparent body drain socket.

## VRV Indoor Units

### Ceiling Mounted Cassette Corner Type

**FXKQ32AV / FXKQ40AV  
FXKQ50AV / FXKQ63AV**



New

This new Indoor unit has been awarded with Good Design Award



- Very Compact & Elegant Design
- Sleek panel with dual tone styling that give rational choice of elegancy
- Flexibility to install on several height false ceiling minimum up to 3.9 inches (100mm) with the help of multiple spacers (Optional).

White Color Panel

Silver Color Panel



Base Color: Black  
Surface color: White

Base Color: White  
Surface color: White

Base Color: Black  
Surface color: Silver





## VRV Indoor Units

### Slim Ceiling Mounted Duct Type

**FXDQ20PD / FXDQ25PD / FXDQ32PD  
FXDQ40ND / FXDQ50ND / FXDQ63ND**

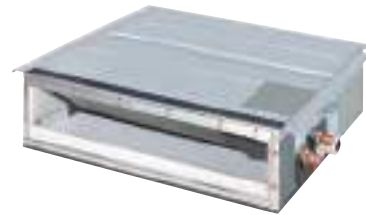

**VRT Smart Control**

### Slim design, quietness and static pressure switching

#### Suited to use in drop-ceilings

- Only 700mm in width and 23 kg in weight, this model is suitable for installation in limited spaces like drop-ceilings in hotels.

**Great for hotel use**

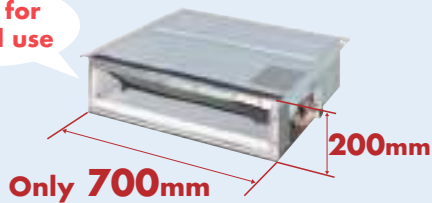

- Only 200mm in height, this model can be installed in rooms with as little as 240mm depth between the drop-ceiling and ceiling slab.

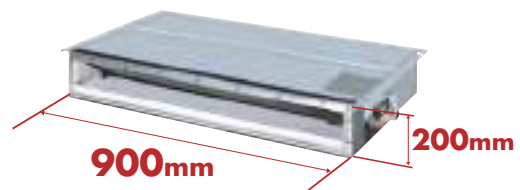

\* 1,100mm in width for the FXDQ63ND model.

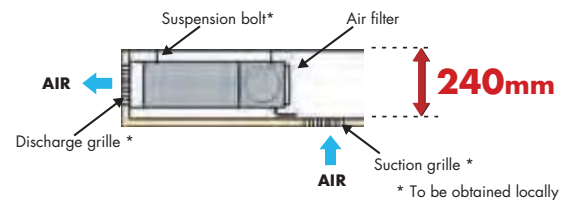

- Control of the airflow rate has been improved from 2-step to 3-step control.

Low operation sound level (dBA)

FXDQ-PD/ND	20/25/32	40	50	63
Sound level (HH/H/L)	33/31/29	34/32/30	35/33/31	36/34/32

\* The values of operation sound level represent those for rear-suction operation. Sound level values for bottom-suction operation can be obtained by adding 5 dBA.

\* Values are based on the following conditions:  
FXDQ-PD: external static pressure of 10 Pa; FXDQ-ND: external static pressure of 15 Pa.

- External static pressure selectable by remote controller switching makes this indoor unit a very comfortable and flexible model.

10 Pa-30 Pa/factory set: 10 Pa for FXDQ-PD models.  
15 Pa-44 Pa/factory set: 15 Pa for FXDQ-ND models.

- FXDQ-PD and FXDQ-ND models are available with a drain pump as a standard accessory.

FXDQ-PD/NDVE: with a drain pump (750mm lift) as a standard accessory

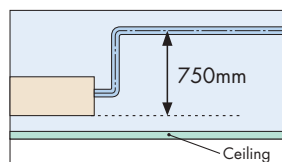

## High Static Pressure Ceiling Mounted Duct Type

**FXMQ20P / FXMQ25P / FXMQ32P  
FXMQ40P / FXMQ50P / FXMQ63P  
FXMQ80P / FXMQ100P / FXMQ125P  
FXMQ140P**



VRT Smart Control

### High static pressure allows for flexible duct design

- A DC fan motor increases the external static pressure capacity range to include middle to high static pressures, increasing design flexibility.

30 Pa-100 Pa for FXMQ20P-32P

30 Pa-160 Pa for FXMQ40P

50 Pa-200 Pa for FXMQ50P-125P

50 Pa-140 Pa for FXMQ140P

All models are only 300mm in height, an improvement over the 390mm height of conventional models. The weight of the FXMQ40P has been reduced from 44 kg to 28 kg.

Drain pump is equipped as standard accessory with 700mm lift.

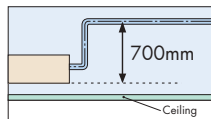

Control of the airflow rate has been improved from 2-step to 3-step control.

Low operation sound level (dBA)

FXMQ-P	20/25	32	40	50	63	80/100	125	140
Sound level (HH/H/L)	33/31/29	34/32/30	39/37/35	41/39/37	42/40/38	43/41/39	44/42/40	46/45/43

#### Energy-efficient

- The adopted DC fan motor is much more efficient than the conventional AC motor, yielding an approximate 20% decrease in energy consumption (FXMQ125P).



#### Improved ease of installation

- Airflow rate can be controlled using a remote controller during test operations. With the conventional model, the airflow rate was controlled from the PC board. It is automatically adjusted to the range between approximately  $\pm 10\%$  of the rated HH tap airflow for FXMQ20P-125P.

#### Improved ease of maintenance

- The drain pan can be detached for easy cleaning. An antibacterial treatment that uses silver ions has been applied to the drain pan, preventing the growth of slime, mould and bacteria that cause blockages and odours.

**FXMQ170N/FXMQ200N  
FXMQ250N**



#### Simplified Static Pressure Control

External static pressure can be easily adjusted using a change-over switch inside the electrical box to meet the resistance in the duct system.

## VRV Indoor Units

### Mid Static Pressure Ceiling Mounted Duct Type

**FXMQ40A / FXMQ50A / FXMQ63A  
FXMQ80A / FXMQ100A**



### Mid static pressure allows for flexible duct design

- AC fan motor is installed to suit applications where external static pressure is required at nominal capacity.  
30 Pa-50 Pa for FXMQ40-80ARV16  
30 Pa-60 Pa for FXMQ100ARV16

All models are only 300mm in height, an improvement over the 390mm height of conventional models. The weight of the FXMQ40P has been reduced from 44 kg to 28 kg.

Drain pump is equipped as standard accessory with 700mm lift.

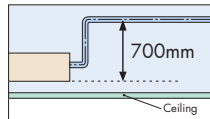

#### High airflow rate

Airflow rate is optimised to meet wider spectrum of airflow requirements.

Low operation sound level (dBA)

FXMQ-A	40	50	63	80	100
Sound level (H/L)	39/37	41/39	42/40	43/41	44/42

#### Improved ease of maintenance

- The drain pan can be detached for easy cleaning. An antibacterial treatment that uses silver ions has been applied to the drain pan, preventing the growth of slime, mould and bacteria that cause blockages and odours.

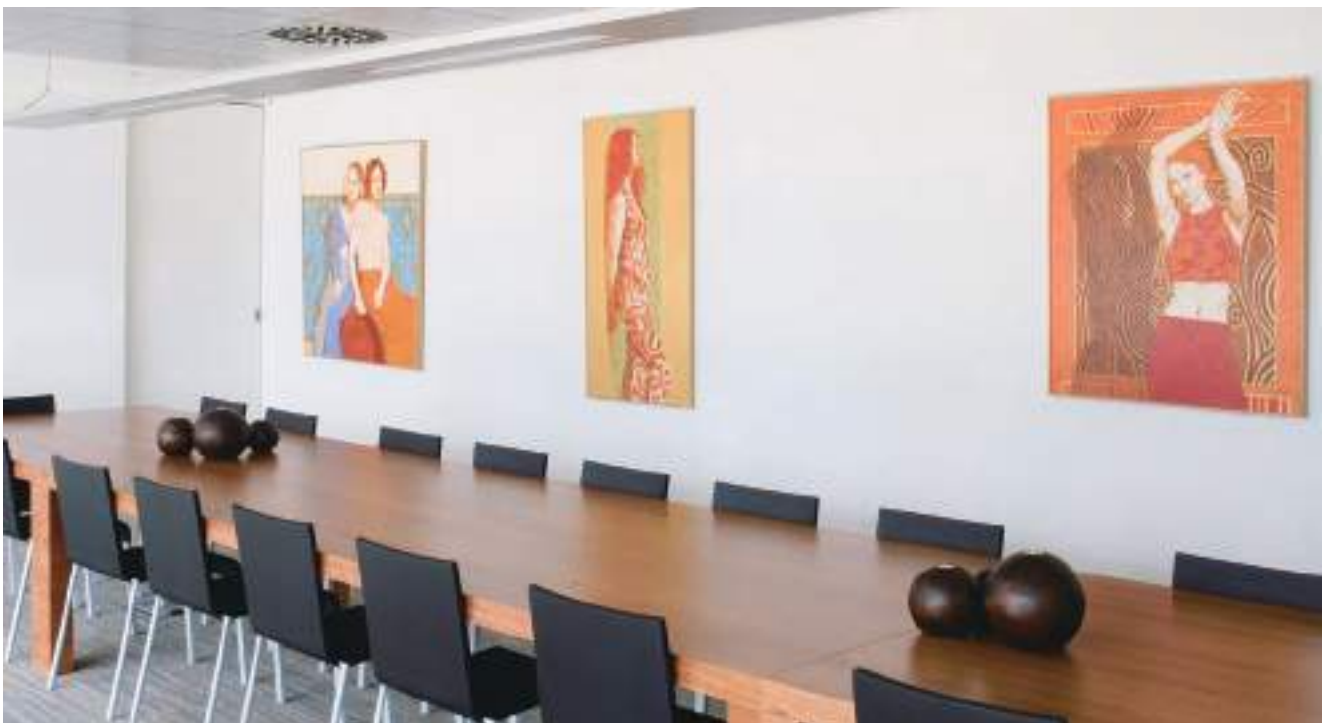

## Ceiling Suspended Type

### Slim body with quiet and wide airflow

FXHQ32 / 63 / 100MA

FXHQ125 / 140A



#### New 125 / 140 models provide greater capacity for large spaces

- The technology of the DC fan motor, wide sirocco fan, and large heat exchanger combine for greater airflow and quiet operation.

- Sophisticated design
  - Flap neatly closes when not in use.



- Suitable for high ceilings

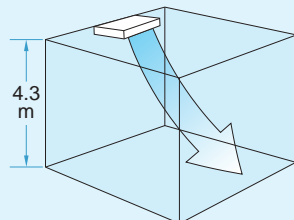

- Switchable fan speed: 3 steps
  - Control of airflow rate has been improved from 2-step to 3-step.

- Drain pump kit (option) includes a silver ion antibacterial agent that assists in preventing the growth of slime, bacteria, and mould that cause smells and clogging.



#### Comfort

- Auto swing (up and down) and louvers (left and right by hand) bring comfort to the room.
- Louver manually adjusts for straight or wide angle airflow.

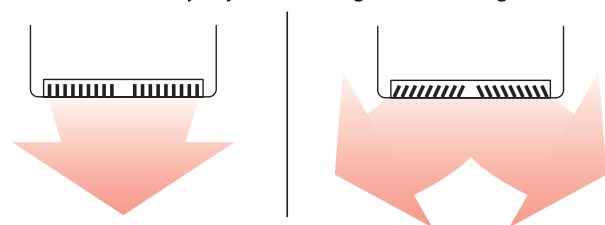

#### Quiet operation

- Uses quiet stream fan and other quiet technologies. (FXHQ32-100MA)

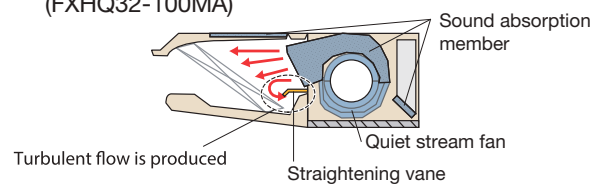

dB(A)

Indoor unit	Sound level		
	H	M	L
FXHQ32MA	36	—	31
FXHQ63MA	39	—	34
FXHQ100MA	45	—	37
FXHQ125A	46	41	37
FXHQ140A	48	42	37

## VRV Indoor Units

### Wall Mounted Type

**FXAQ20A / FXAQ25A  
FXAQ32A / FXAQ40A  
FXAQ50A / FXAQ63A**

**VRT Smart Control**



**Stylish flat panel design harmonised  
with your interior décor**



- Stylish flat panel design creates a graceful harmony that enhances any interior space.
- Flat panel can be cleaned with only the single pass of a cloth across their smooth surface.
- Vertical auto-swing realises efficiency of air distribution. The louvre closes automatically when the unit stops.

## Floor Standing Type

**FXLQ32MA / FXLQ50MA  
FXLQ63MA**



### Suitable for perimeter zone air conditioning

- Floor Standing types can be hung on the wall for easier cleaning. Running the piping from the back allows the unit to be hung on walls. Cleaning under the unit, where dust tends to accumulate, is considerably easier.
- The adoption of a fibre-less discharge grille, featuring an original design to prevent condensation, also helps prevent staining and makes cleaning easier.
- A long-life filter is equipped as standard accessory.  
\*8 hr/day, 25 day/month. For dust concentration of 0.15 mg/m<sup>3</sup>

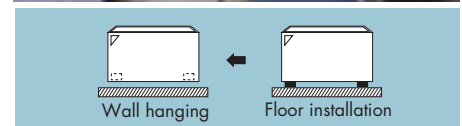

## Concealed Floor Standing Type

**FXNQ32MA / FXNQ50MA  
FXNQ63MA**



### Designed to be concealed in the perimeter skirting-wall

- The unit is concealed in the skirting-wall of the perimeter, that creates a classy interior design.
- The connecting port faces downwards, greatly facilitating on-site piping work.
- A long-life filter is equipped as a standard accessory.  
\* 8 hr/day, 25 day/month. For dust concentration of 0.15 mg/m<sup>3</sup>

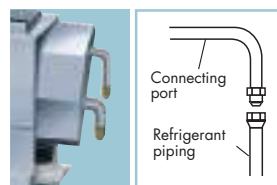

\* Applies also to Floor Standing type (FXLQ-MA).



## VRV Indoor Units

### Floor Standing Duct Type

**FXVQ125N / FXVQ200N  
FXVQ250N / FXVQ400N  
FXVQ500NY16**



**Large airflow type for large spaces.  
Flexible interior design for each customer.**

- Large airflow type that fits for spacious areas such as factories and large stores.
- Various installations can be supported from full-scale duct connection airflow to direct airflow that allows for easy installation.
- Full-scale duct connection airflow allows for air conditioning evenly in spacious areas.

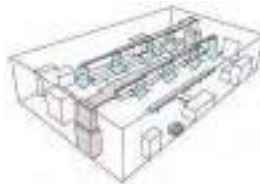

#### Duct connection airflow type

- Adding the plenum chamber (option) allows for simple operation with direct airflow.

\* Note that the operation sound increases by approximately 5 dBA.

#### Direct airflow type

- The high static pressure type driven by the belt drive system allows the usage of air discharge outlets in various shapes as well as long ducts. Highly flexible installation is possible.
- High maintainability design that allows major services and maintenance services to be performed at the front.
- A long-life filter is equipped as a standard accessory.  
\*8 hr/day, 26 day/month. For dust concentration of 0.15 mg/m<sup>3</sup>
- A wide range of optional accessories is available such as high-efficiency filters.



- Outdoor air intake mode is useable as an outdoor-air processing air conditioner.

\*When using the unit as an outdoor-air processing unit, there are some restrictions.

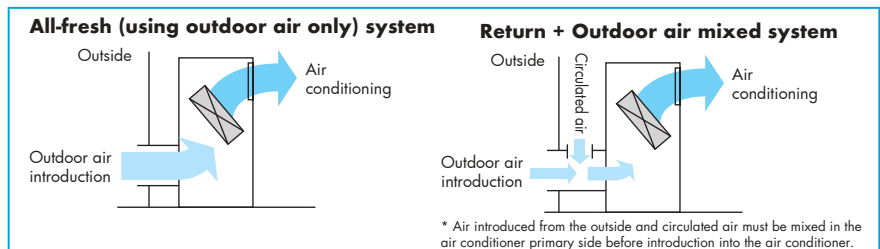

## 4-Way Flow Ceiling Suspended Type

**FXUQ71A / FXUQ100A**



**This slim and stylish indoor unit achieves optimum air distribution and can be installed without a ceiling cavity.**

- Unit body and suction panel adopted round shapes and realized a slim appearance design. The unit can be used for various locations such as the ceilings with no cavity and bore ceilings.
- Flaps close automatically when the unit stops, which gives a simple appearance.
- Unified slim height of 198mm for all models that gives the unified impression even when models with different capacities are installed in the same area.
- Built-in electronic expansion valve eliminates the need for a BEV unit, which improves flexibility of installation.

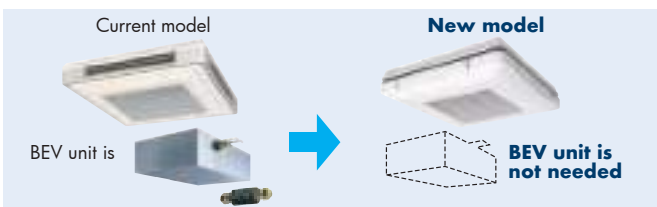

- With adoption of the individual flap control, airflow direction adjustment can be individually set for each air outlet. Five directions of airflow and auto-swing can be selected with wired remote controller BRC1E62, which realizes the optimum air distribution.

### Individual airflow direction example case

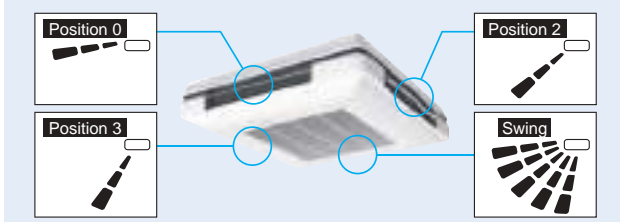

- Control of the airflow rate has been improved from 2-step to 3-step control. Auto airflow rate control can be selected with wired remote controller BRC1E62.
- Energy efficiency has been improved, thanks to the adoption of new heat exchanger with smaller tubes, DC fan motor and DC drain pump motor.
- Drain pump is equipped as a standard accessory and the lift height has been improved from 500mm to 600mm.
- Depending on the installation site requirements or room conditions, 2-way, 3-way and 4-way discharge patterns are available.

4-way flow



3-way flow



L-shaped 2-way flow

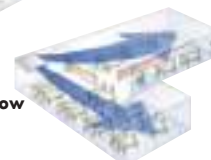

## VRV Indoor Units

### Clean Room Type Air Conditioner

**FXBQ40/FXBQ50  
FXBQ63/FXBPQ63**



### Suitable for hospitals and other clean spaces

Easily provides the high cleanliness environment required by various industries

Daikin's clean room air conditioners are specially designed to achieve an environment cleanliness class 10,000. These air conditioners easily realize a cleanliness - class environment and help create a proper environment of hospitals, food and beverage factories, electronics factories and other spaces that require clean air.

Select the air flow system and installation method to match the layout and purpose of the room

Two types of clean room air conditioners are available – an integrated unit model and a separate outlet unit model. It is also possible to configure the air flow system to ceiling intake or floor-level intake according to the panel selected. This flexible design enables the air conditioner to easily adapt to any room layout or use.

Instances of installation by type (for a hospital)

Type	Ceiling intake type (high speed contracted flow/high ceiling model)	Floor-level intake type (gentle wind distribution/high cleanliness class model)
Features	Construction work is simple and a ceiling installation is possible. Dust filtering and air-conditioning can be started immediately.	Easy to increase the cleanliness and air-conditioning effect. A low flow speed prevents drying of the affected part and the experience of drafts.
Cleanness class*1	100,000 to 10,000	10,000
Wind speed	1.0m/s or higher	Approximately 0.5m/s
Blow method	<b>Integrated outlet unit model</b> <ul style="list-style-type: none"> <li>Concentrated air conditioning centered directly under the unit</li> <li>Easy installation</li> </ul> <p>Applications: Surgery prep rooms, recovery rooms, nurse stations, etc.</p>	<ul style="list-style-type: none"> <li>Total air conditioning with an emphasis on cleanliness</li> </ul> <p>Applications: Operating theatres, delivery rooms, etc.</p>
	<b>Separate outlet unit model</b> <ul style="list-style-type: none"> <li>Somewhat concentrated air conditioning centered directly under the outlet</li> <li>Can provide air conditioning in rooms with irregular shapes</li> </ul> <p>Applications: CCU*2, sterile rooms, etc.</p>	<ul style="list-style-type: none"> <li>Total air conditioning with an emphasis on cleanliness</li> <li>Maintenance possible from a different room</li> </ul> <p>Applications: Premature nurseries, newborn nurseries, ICU*3, etc.</p>

\*1. Cleanliness class. A scale expressing the cleanliness of air established by NASA (National Aeronautics and Space Administration). Class 10,000 represents a state of less than 10,000 minute particles of diameter under 0.5 μm per cubic foot. For comparison, the cleanliness of a typical office is around class 1,000,000.

\*2. CCU (Cardiac Care Unit). A ward dedicated to the admission of patients with myocardial infarctions and other heart diseases.

\*3. ICU (Intensive Care Unit). A ward for the careful treatment and nursing of patients with serious illnesses, injuries, or recovering from operations.

### Can be easily installed in existing buildings

A simple structure makes it easy to realize a highly clean environment with the same installation work as for a typical air conditioner. Can be easily installed in new buildings, existing structures and refurbishments.

### Prevents uncomfortable drafts with a low flow speed of approximately 0.5m/s

The floor-level intake system has a low flow speed of approximately 0.5 m/s, improving dust filtration and eliminating the feeling of drafts. Broadly air-conditions the room with a gentle air flow and creates a comfortable environment.

• Air flow distribution diagram (operating theatre)

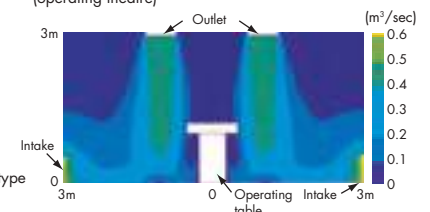

\* Analysis of the floor-level intake type with the integrated outlet model.

FXB(P)Q-P

## Filtration

### Class 10,000 clean room condition achieved with a HEPA filter (sold separately)

The low pressure-loss HEPA filter (sold separately) demonstrates superior dust filtering performance and easily accomplishes an air cleanliness of class 10,000.

The HEPA filter has a structure incorporating a pleated glass fibre filter medium, making it highly efficient and suitable for clean rooms, etc.

- HEPA filter

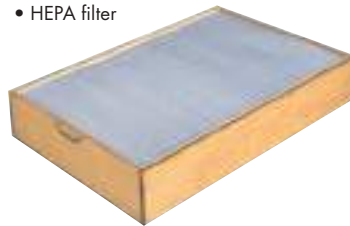

Installation example (in a medical facility)

\*It may not be possible to maintain cleanliness in rooms with low air tightness.

## Antibacterial

### Suppresses the propagation of bacteria in the duct with a proprietary antibacterial coating.

The filter implements an antibacterial treatment with a new coating, combining a silver-based inorganic antibacterial material (an organic antibacterial material that is effective against germs) that prevents mould. This enhances the antibacterial properties of the duct. An antibacterial treatment using a silver-based organic substance reduces mould.

### Antibacterial fibre used in the intake filter.

With a long-life filter employing anti-mould antibacterial fibre near the intake, cleaning performance is further enhanced.

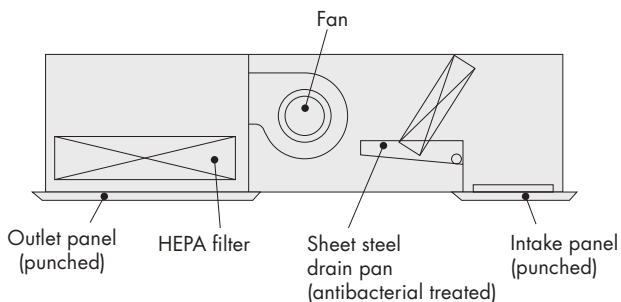

- \* Please be aware that antibacterial products suppress the propagation of bacteria but do not have a sterilising effect. Also, mould may grow in places where dust or soot accumulates.
- \* A material for which the registered safety was verified by Japanese chemicals and dangerous substances regulation law (Act on the Evaluation of Chemical Substances and Regulation of Their Manufacture, etc.) is used for the antibacterial material.
- \* Periodic maintenance is required (such as cleaning the air filter and washing the inside to the unit).

## Labour-saving

### Filter maintenance unnecessary for about five years Easy access from underneath unit provides easy maintenance.

The HEPA filter has an exceptionally long life and does not require maintenance for about five years. Daikin has aimed to reduce maintenance work from a variety of perspectives, including a service access system that eliminates the necessity for service panels.

\*The maintenance period differs significantly according to the cleanliness of the room and hours of air conditioner operation.

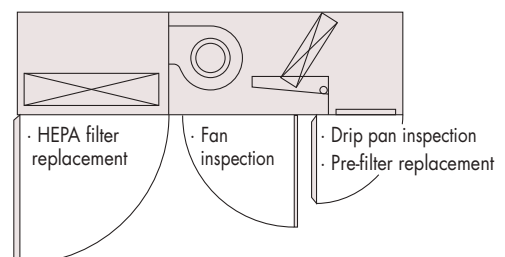

## Quiet

### All models incorporate an industry-leading quiet design, operating at under 41dB.

Operating noise is substantially reduced by employing a proprietary double-structure outlet filter chamber, sound absorbing insulation and a low pressure-loss HEPA filter. Sound level of all models are under 41 dB (38dB during low-fan speed operation).

\*Operating noise may be greater than these values in highly reflective locations.

## VRV Indoor Units

### Multi Cube (Spot AC) type for VRV system

**FXPQ25AVM**

**New**



### Personal air comfort delivered to large spaces

Even in large spaces, Daikin ensures individual air comfort for each person. Our compact Spot Air Conditioner was created to serve individual air conditioning needs in large spaces. Compared to commercial buildings and offices, air conditioning factories and other large spaces used to be extremely difficult. With this Spot Air Conditioner, temperatures can now be individually adjusted for a comfortable work environment to suit each person.

Wind travel distance  
**30%<sup>-1</sup> increase**  
(during direct airflow)

Wind velocity  
**20%<sup>-2</sup> increase in**  
(during duct connection)

\*1. This compares the distance in which airflow travels from the air outlet at wind velocity of 3 m/s with the distance that airflow travels for the conventional FXPQ25AVN.

\*2. This is a comparison of wind velocity with the connected to a  $\phi$  350 duct.

**Delivering greater comfort by adopting a high efficiency DC motor and optimizing the shape of the air discharge grille.**

**Flexible installation corresponds to site conditions. With temperature control available for each unit, air conditioning adjusts to individual preferences for personal air comfort.**

**Different types of installation possible**

Suspended	Rested
	<ul style="list-style-type: none"> <li>Stand installation (stand sold separately)</li> <li>Direct installation</li> </ul>

Installation examples at Daikin's Sakai and Rinkai plants

### Versatile installation options enable free layout

Because **VRV** systems allow use of long refrigerant piping, unit layout is flexible and can be freely designed to fit large spaces. Not only does this make ductwork unnecessary, it simplifies installation and enables easy unit relocation in the future. Installation costs are also greatly reduced.

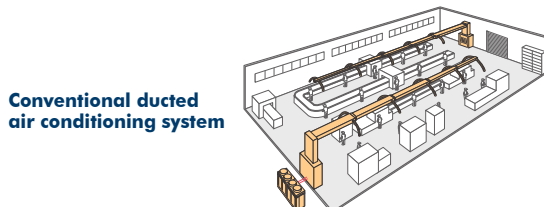

**No ducts required!**

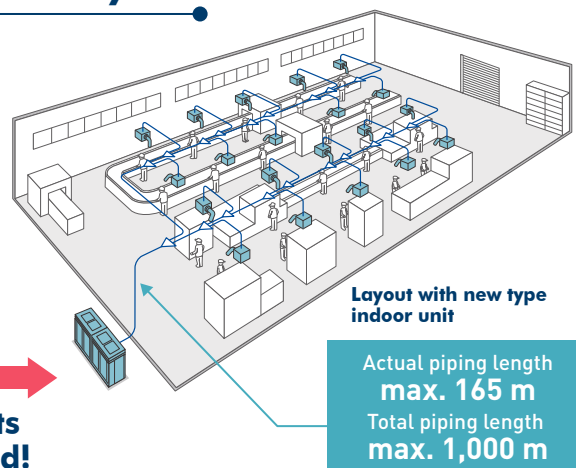

## Easy relocation/expansion

Only requirement is connection to preinstalled Shut-off Valve kit for additional indoor units (Option).



## Adjustable comfort for individual users

Each Spot Air Conditioner can be controlled with a dedicated wired remote controller. Individual users can set the temperature and airflow volume.

Moreover, since each unit can be turned ON and OFF, it is possible to reduce power consumption resulting from unnecessary operation and to eliminate associated costs.

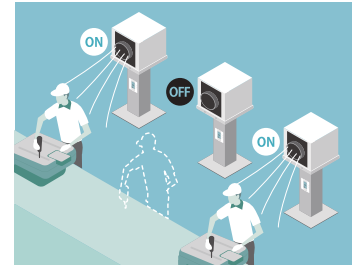

## Delivering comfort with a large volume of air

The large propeller fan provides a gentle, comfortable breeze and greater wind volume.

Additionally, by installing an optional air discharge adaptor and straightening plate, strong airflow can be achieved that extends even further.

### Comfort for people nearby **Standard type**

#### Wind velocity distribution map (horizontal section)

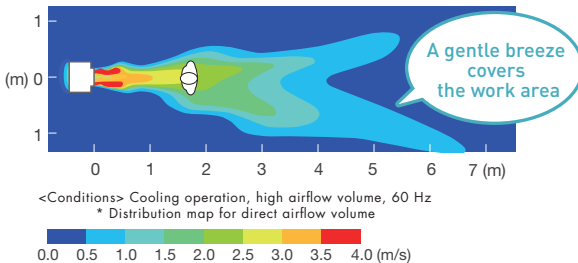

### Comfort for people far away **Long-distance type**<sup>\*6</sup>

#### Wind velocity distribution map (horizontal section)

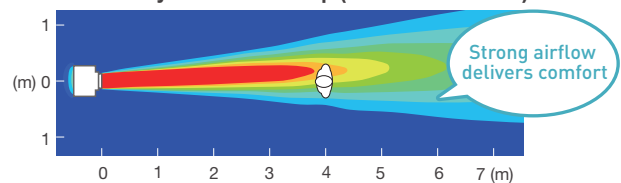

\*6. Installation of the optional items "air discharge adaptor (KDF87C28)" and "straightening plate for air discharge adaptor (KPW87A28)" is necessary.

## Designed for installation in any environment

### Withstands oil mists

For the heat exchanger cooling pipe, a material with **3 to 6 times<sup>\*7</sup> the durability** of standard materials has been selected.

### Leakage failsafe

An **emergency reservoir** is fitted in the underframe beneath the drain pan. This provides reassuring backup against drain pan overflow.

### Condensation suppression

To **minimize condensation**, the air duct and blowout tubes are **double insulated**. This enables use in kitchens and other highly humid environment.

### Simple maintenance

**Easy maintenance design** includes front access for fan motor replacement.

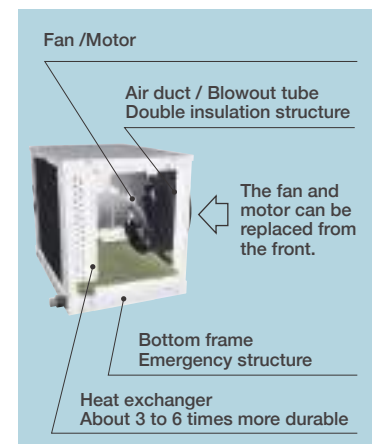



**VRV X**

**SPECIFICATIONS**

## VRV Indoor Units

### Ceiling Mounted Cassette Round Flow & Round Flow with Sensing (Optional)



MODEL		FXFSQ25ARV16	FXFSQ32ARV16	FXFSQ40ARV16	FXFSQ50ARV16	FXFSQ63ARV16	FXFSQ80ARV16	FXFSQ100ARV16	FXFSQ125ARV16	FXFSQ140ARV16								
Power supply		1-phase, 220-240V, 50Hz																
Cooling capacity	Btu/h	9,600	12,300	15,400	19,100	24,200	30,700	38,200	47,800	54,600								
	kW	2.8	3.6	4.5	5.6	7.1	9.0	11.2	14.0	16.0								
Heating capacity	Btu/h	10,900	13,600	17,100	21,500	27,300	34,100	42,700	54,600	54,600								
	kW	3.2	4.0	5.0	6.3	8.0	10.0	12.5	16.0	16.0								
Casing		Galvanised steel plate																
Airflow rate (H/HM/M/ML/L)	m <sup>3</sup> /min	13/12.5/11.5/11/10			17/13.5/12.5/12/11		23/20.5/19/14.5/11		23.5/21/20/16/13.5		24.5/22/20.5/20/15		33.5/30.5/27/23.5/21		34.5/31.5/28.5/25.5/23		35.5/32.5/29.5/26.5/23	
	cfm	459/441/406/388/353			600/477/441/424/388		812/724/671/512/388		830/742/706/565/477		865/777/724/706/530		1,163/1,077/954/830/742		1,218/1,112/1,006/901/812		1,254/1,148/1,042/936/812	
Sound level (H/HM/M/ML/L)	dBA	30/29.5/28.5/28/27			35/29.5/29/28/27		38/35/34.5/29.5/27		38/36/35.5/31.5/28		39/37/36/35.5/31		44/41/38/35/33		45/42.5/39.5/37/35		46/43.5/40.5/38/35	
Dimensions (HxWxD)	mm	256x840x840						298x840x840										
Machine weight	kg	19				22		25		26								
Piping connections	Liquid (Flare)	ø 6.4				ø 9.5												
	Gas (Flare)	ø 12.7				ø 15.9												
	Drain	VP25 (External Dia, 32/Internal Dia, 25)																
Standard panel (Non sensing) (White)	Model	BYCQ125EAF6 (Fresh White)																
	Dimensions (HxWxD)	50x950x950																
	Weight	5.5																
Sensing panel (White)	Model	BYCQ140EEF6 (Fresh White)																
	Dimensions (HxWxD)	50x950x950																
	Weight	5.5																

Note: Specifications are based on the following conditions;

- Cooling: Indoor temp.: 27°CDB, 19°CWB, Outdoor temp.: 35°CDB, Equivalent piping length: 7.5 m, Level difference: 0 m.
- Heating: Indoor temp.: 20°CDB, Outdoor temp.: 7°CDB, 6°CDB Equivalent piping length: 7.5 m, Level difference: 0 m.
- Capacity of indoor unit is only for reference. Actual capacity of indoor unit is based on the total capacity index. (See Engineering Data Book for details.)
- Sound level: Anechoic chamber conversion value, measured at a point 1.5 m downward from the unit centre. During actual operation, these values are normally somewhat higher as a result of ambient conditions.



### Decoration Panel (Option)

		ROUND FLOW TYPE	
		FXFSQ-A	
Standard panel	MODEL	BYCQ125EAF6 (Fresh White) / BYCQ125EAK (Black)	
	Dimensions (HxWxD)	mm	50x950x950
	Weight	kg	5.5
Sensing panel	Model	BYCQ140EEF6 (Fresh White) / BYCQ125EEK	
	Dimensions (HxWxD)	mm	50x950x950
	Weight	kg	5.5
Designer panel	Model	BYCQ125EAPF (Fresh White)	
	Dimensions (HxWxD)	mm	97x950x950
	Weight	kg	6.5
Auto grille panel	Model	BYCQ125EASF (Fresh White)	
	Dimensions (HxWxD)	mm	105x950x950
	Weight	kg	8



**Standard panel**  
BYCQ125EAF6 (Fresh White)



**Standard panel**  
BYCQ125EAK (Black)



**Designer panel**  
BYCQ125EAPF (Fresh White)



**Sensing panel**  
BYCQ140EEF6 (Fresh White)



**Sensing panel**  
BYCQ125EEK (Black)



**Auto grille panel<sup>2</sup>**  
BYCQ125EASF (Fresh White)

Note: When opting Black panel, wireless remote controller model will be BRC7M634K

## VRV Indoor Units

### Ceiling Mounted Cassette (Compact Multi-Flow) Type



MODEL		FXZQ20AVM	FXZQ25AVM	FXZQ 32AVM	FXZQ40AVM	FXZQ50AVM
Power supply		1-Phase, 220-240 V, 50Hz				
Cooling capacity	Btu/h	7,500	9,600	12,300	15,400	19,100
	kW	2.2	2.8	3.6	4.5	5.6
Heating capacity	Btu/h	8,500	10,900	13,600	17,100	21,500
	kW	2.5	3.2	4.0	5.0	6.3
Casing		Galvanised steel plate				
Airflow rate (H/M/L)	m <sup>3</sup> /min	8.7/7.5/6.5	9.0/8.0/6.5	10.0/8.5/7.0	11.5/9.5/8.0	14.5/12.5/10.0
	cfm	307/265/229	318/282/229	353/300/247	406/335/282	512/441/353
Sound level (H/M/L)		32.0/29.5/25.5	33.0/30.0/25.5	33.5/30.0/26.0	37.0/32.0/28.0	43.0/40.0/33.0
Dimensions (HxWxD)		260x575x575 (For depth add 63mm for electrical box)				
Machine weight		15.5		16.5		18.5
Piping connections	Liquid (Flare)	ø6.4				
	Gas (Flare)	ø12.7				
	Drain	VP20 (External Dia. 26/Internal Dia. 20)				

Note: Specifications are based on the following conditions;

- Cooling: Indoor temp.: 27°CDB, 19°CWB, Outdoor temp.: 35°CDB, Equivalent piping length: 7.5 m, Level difference: 0 m.
- Heating: Indoor temp.: 20°CDB, Outdoor temp.: 7°CDB, 6°CWB, Equivalent piping length: 7.5 m, Level difference: 0 m.
- Capacity of indoor unit is only for reference. Actual capacity of indoor unit is based on the total capacity index. (See Engineering Data Book for details.)
- Sound level: Anechoic chamber conversion value, measured at a point 1.5 m downward from the unit centre.  
During actual operation, these values are normally somewhat higher as a result of ambient conditions.

### Ceiling Mounted Cassette (Double Flow) Type



MODEL		FXCQ25AVM	FXCQ32AVM	FXCQ40AVM	FXCQ50AVM	FXCQ63AVM	FXCQ80AVM	FXCQ125AVM	
Power supply		1-phase, 220-240 V/50 Hz							
Cooling capacity	Btu/h	9,600	12,300	15,400	19,100	24,200	30,700	47,800	
	kW	2.8	3.6	4.5	5.6	7.1	9.0	14.0	
Heating capacity	Btu/h	10,900	13,600	17,100	21,500	27,300	34,100	54,600	
	kW	3.2	4.0	5.0	6.3	8.0	10.0	16.0	
Casing		Galvanised steel plate							
Airflow rate (HH/M/L)	m <sup>3</sup> /min	11.5/10.5/9.5/8.5/8		12/11/10.5/9.5/8.5	15/14/13/11.5/10.5	16/15/14/12.5/11.5	26/24/22.5/20.5/18.5	32/29.5/27.5/25/22.5	
	cfm	406/371/335/300/282		424/388/371/335/300	530/494/459/406/371	565/530/494/441/406	918/847/794/724/653	1130/1041/971/883/794	
Sound level (H/L) 220 V		34/33/31/30/29	34/33/32/31/30	36/35/33/32/31	37/36/35/33/31	39/38/37/35/32	42/40/38/36/33	46/44/42/40/38	
Dimensions (HxWxD)		305x775x620		305x990x620		305x1,445x620			
Machine weight		19		22		25	33	38	
Piping connections	Liquid (Flare)	ø6.4					ø9.5		
	Gas (Flare)	ø12.7					ø15.9		
	Drain	VP25 (External Dia, 32/Internal Dia, 25)							
Panel (Option)	Model	BYBCQ40CF		BYBCQ63CF		BYBCQ125CF			
	Colour	Fresh white (6.5Y 9.5/0.5)							
	Dimensions(HxWxD)	55x1,070x700		55x1,285x700		55x1,740x700			
	Weight	10		11		13			

## Ceiling Mounted Cassette Corner Type



MODEL			FXKQ32AV16	FXKQ40AV16
Power supply			1 phase, 220-240 V, 50 Hz	1 phase, 220-240 V, 50 Hz
★1 ★3 Cooling capacity	Btu/h		12,300	15,400
	kW		3.6	4.5
★2 ★3 Heating capacity	Btu/h		12,300	15,400
	kW		3.6	4.5
Casing / Colour			Galvanized steel plate	Galvanized steel plate
Dimensions: (H × W × D)		mm	145 × 1,210 × 523	145 × 1,210 × 523
Fan	Airflow rate (H / HM M / ML / L)	m <sup>3</sup> /min	9.7 / 9.3 / 8.9 / 8.7 / 8.5	11.1 / 10.3 / 9.5 / 9.0 / 8.6
		cfm	342 / 328 / 314 / 307 / 300	392 / 364 / 335 / 318 / 304
Piping connections	Liquid pipes	mm	φ6.4 (flare connection)	φ6.4 (flare connection)
	Gas pipes	mm	φ12.7 (flare connection)	φ12.7 (flare connection)
	Drain pipe	mm	φ26 (hole)	φ26 (hole)
Mass		kg	20	20
★4 Sound pressure level (H / HM / M / ML / L)		dBA	36 / 35 / 34 / 34 / 33	39 / 37 / 36 / 35 / 34
Decoration panel (option)	Model		Fuse	
			BYKQ63AHW / BYKQ63AHS / BYKQ63AW	
	Colour		White / Silver	
	Dimensions: (H × W × D) mm		41 x 1390 x 595	
	Air filter		Resin net (with mould resistance)	
Mass		kg	6.6	

### Note:

- ★1. Indoor temp.: 27°CDB, 19°CWB / outdoor temp.: 35°CDB, 24°CWB / Equivalent piping length: 7.5 m, height difference: 0 m.
- ★2. Indoor temp.: 20°CDB, 15°CWB / outdoor temp.: 7°CDB, 6°CWB / Equivalent piping length: 7.5 m, height difference: 0 m.
- ★3. Capacities are net, including a deduction for cooling (an addition for heating) for indoor fan motor heat.
- ★4. Anechoic chamber conversion value, measured at a point 1 m in front of the unit and 1.0 m downward. During actual operation, these values are normally somewhat higher as a result of ambient conditions.

Conversion formulae
kcal/h = kW × 860
Btu/h = kW × 3,412
cfm = m <sup>3</sup> /min × 35.3
l/s = m <sup>3</sup> /min × 1,000/60

## VRV Indoor Units

### Ceiling Mounted Cassette Corner Type



MODEL			FXKQ50AV16	FXKQ63AV16	
Power supply			1 phase, 220-240 V, 50 Hz	1 phase, 220-240 V, 50 Hz	
★1 ★3 Cooling capacity	Btu/h		19,100	24,200	
	kW		5.6	7.1	
★2 ★3 Heating capacity	Btu/h		19,100	24,200	
	kW		5.6	7.1	
Casing / Colour			Galvanized steel plate	Galvanized steel plate	
Dimensions: (H × W × D)		mm	145 × 1,210 × 523	145 × 1,210 × 523	
Fan	Airflow rate (H / HM / M / ML / L)	m <sup>3</sup> /min	13.2 / 12.2 / 11.1 / 10.3 / 9.5	17.4 / 15.4 / 13.9 / 12.4 / 10.8	
		cfm	466 / 431 / 392 / 364 / 335	614 / 544 / 491 / 438 / 381	
Piping connections	Liquid pipes	mm	φ6.4 (flare connection)	φ9.5 (flare connection)	
	Gas pipes	mm	φ12.7 (flare connection)	φ15.9 (flare connection)	
	Drain pipe	mm	φ26 (hole)	φ26 (hole)	
Mass		kg	20	20	
★4 Sound pressure level (H / HM / M / ML / L)		dBA	43 / 41 / 39 / 37 / 36	49 / 47 / 45 / 43 / 41	
Decoration panel (option)	Model		BYKQ63AHW / BYKQ63AHS / BYKQ63AW		
	Colour		White / Silver		
	Dimensions: (H × W × D)		mm	41 x 1390 x 595	
	Air filter		Resin net (with mould resistance)		
	Mass		kg	6.6	

**Note:**

- ★1. Indoor temp.: 27°CDB, 19°CWB / outdoor temp.: 35°CDB, 24°CWB / Equivalent piping length: 7.5 m, height difference: 0 m.
- ★2. Indoor temp.: 20°CDB, 15°CWB / outdoor temp.: 7°CDB, 6°CWB / Equivalent piping length: 7.5 m, height difference: 0 m.
- ★3. Capacities are net, including a deduction for cooling (an addition for heating) for indoor fan motor heat.
- ★4. Anechoic chamber conversion value, measured at a point 1 m in front of the unit and 1.0 m downward. During actual operation, these values are normally somewhat higher as a result of ambient conditions.

Conversion formulae
kcal/h = kW × 860
Btu/h = kW × 3,412
cfm = m <sup>3</sup> /min × 35.3
l/s = m <sup>3</sup> /min × 1,000/60

## Slim Ceiling Mounted Duct Type (700 mm width type)

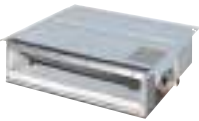

MODEL	with drain pump	FXDQ20PDV36	FXDQ25PDV36	FXDQ32PDV36
Power supply		1-phase, 220-240 V/220 V, 50 Hz		
Cooling capacity	Btu/h	7,500	9,600	12,300
	kW	2.2	2.8	3.6
Heating capacity	Btu/h	8,500	10,900	13,600
	kW	2.5	3.2	4.0
Casing		Galvanised steel plate		
Airflow rate (HH/H/L)	m <sup>3</sup> /min	8.0/7.2/6.4	8.0/7.2/6.4	8.0/7.2/6.4
	cfm	282/254/226	282/254/226	282/254/226
External static pressure	Pa	30-10* <sup>2</sup>		
Sound level (HH/H/L) *1*3	dBA	33/31/29	33/31/29	33/31/29
Dimensions (HxWxD)	mm	200x700x620	200x700x620	200x700x620
Machine weight	kg	23.0	23.0	23.0
Piping connections	Liquid (Flare)	ø 6.4	ø 6.4	ø 6.4
	Gas (Flare)	ø 12.7	ø 12.7	ø 12.7
	Drain	VP20 (External Dia, 26/Internal Dia, 20)		

## VRV Indoor Units

### Slim Ceiling Mounted Duct Type (900/1,100 mm width type)

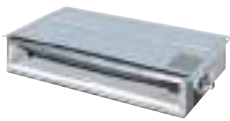

MODEL	with drain pump	FXDQ40NDV36	FXDQ50NDV36	FXDQ63NDV36
Power supply		1-phase, 220-240 V/220 V, 50 Hz		
Cooling capacity	Btu/h	15,400	19,100	24,200
	kW	4.5	5.6	7.1
Heating capacity	Btu/h	17,100	21,500	27,300
	kW	5.0	6.3	8.0
Casing		Galvanized steel plate		
Airflow rate (HH/H/L)	m <sup>3</sup> /min	10.5/9.5/8.5	12.5/11.0/10.0	16.5/14.5/13.0
	cfm	371/335/300	441/388/353	583/512/459
External static pressure	Pa	44-15*2		
Sound level (HH/H/L) **1,3	dB(A)	34/32/30	35/33/31	36/34/32
Dimensions (HxWxD)	mm	200x900x620	200x900x620	200x1,100x620
Machine weight	kg	27.0	28.0	31.0
Piping connections	Liquid (Flare)	ø 6.4	ø 6.4	ø 9.5
	Gas (Flare)	ø 12.7	ø 12.7	ø 15.9
	Drain	VP20 (External Dia, 26/Internal Dia, 20)		

**Note: Specifications are based on the following conditions;**

- Cooling: Indoor temp.: 27°CDB, 19°CWB, Outdoor temp.: 35°CDB, Equivalent piping length: 7.5 m, Level difference: 0 m.
- Heating: Indoor temp.: 20°CDB, Outdoor temp.: 7°CDB, 6°CDB Equivalent piping length: 7.5 m, Level difference: 0 m.
- Capacity of indoor unit is only for reference. Actual capacity of indoor unit is based on the total capacity index.
- Sound level: Anechoic chamber conversion value, measured at a point 1.5 m downward from the unit centre.

During actual operation, these values are normally somewhat higher as a result of ambient conditions.

\* 1: Values are based on the following conditions: FXDQ-P: external static pressure of 10 Pa; FXDQ-N: external static pressure of 15 Pa.

\* 2: External static pressure is changeable to set by the remote controller. This pressure means "High static pressure - Standard".

(Factory setting is 10 Pa for FXDQ-P models and 15 Pa for FXDQ-N models.)

\* 3: The values of operation sound level represent those for rear-suction operation. Sound level values for bottom-suction operation can be obtained by adding 5 dBA.

### Mid Static Pressure Ceiling Mounted Duct Type



MODEL	with drain pump	FXMQ40ARV16	FXMQ50ARV16	FXMQ63ARV16	FXMQ80ARV16	FXMQ100ARV16
Power supply		1-phase, 220-240 V, 50 Hz				
Cooling capacity	Btu/h	15,400	19,100	24,200	30,700	38,200
	kW	4.5	5.6	7.1	9.0	11.2
Heating capacity	Btu/h	17,100	21,500	27,300	34,100	42,700
	kW	5.0	6.3	8.0	10.0	12.5
Casing		Galvanized Steel Plate				
Airflow rate (HH/H/L)	m <sup>3</sup> /min	15/12	19/16	24/20	30/25	34/29
	cfm	530/425	671/565	848/706	1060/883	1200/1024
External static pressure	Pa	30-50				30-60
Sound level (H/L)	dB(A)	39/37	41/39	42/40	43/41	44/42
Dimensions (HxWxD)	mm	300x700x700			300x1000x700	
Machine weight	kg	27	28	35	36	
Piping connections	Liquid (Flare)	6.4 (Flare Connection)			9.5 (Flare Connection)	
	Gas (Flare)	12.7 (Flare Connection)			15.9 (Flare Connection)	
	Drain	VP25 (External Dia. 32, Internal Dia. 25)				

**Note: Specifications are based on the following conditions:**

- Cooling: Indoor temp.: 27°CDB, 19°CWB, Outdoor temp.: 35°CDB, Equivalent piping length: 7.5 m, Level difference: 0 m.
- Heating: Indoor temp.: 20°CDB, Outdoor temp.: 7°CDB, 6°CDB Equivalent piping length: 7.5 m, Level difference: 0 m.
- Capacity of indoor unit is only for reference. Actual capacity of indoor unit is based on the total capacity index.
- Sound level: Anechoic chamber conversion value, measured at a point 1.5 m downward from the unit centre.

## Ceiling Mounted Duct Type



MODEL		FXMQ20PAVE	FXMQ25PAVE	FXMQ32PAVE	FXMQ40PBV36	FXMQ50PBV36
Power supply		1-phase, 220-240 V/220 V, 50 Hz				
Cooling capacity	Btu/h	7,500	9,600	12,300	15,400	19,100
	kW	2.2	2.8	3.6	4.5	5.6
Heating capacity	Btu/h	8,500	10,900	13,600	17,100	21,500
	kW	2.5	3.2	4.0	5.0	6.3
Casing		Galvanised steel plate				
Airflow rate (HH/H/L)	m <sup>3</sup> /min	9/7.5/6.5		9.5/8/7	16/13/11	18/16.5/15
	cfm	318/265/230		335/282/247	565/459/388	635/582/530
External static pressure	Pa	30-100 (50) * <sup>2</sup>			30-160 (100) * <sup>2</sup>	50-200 (100) * <sup>2</sup>
Sound level (HH/H/L)	dBA	33/31/29		34/32/30	39/37/35	41/39/37
Dimensions (HxWxD)	mm	300X550X700			300X700X700	300X1,000X700
Machine weight	kg	25			27	35
Piping connections	Liquid (Flare)	ø 6.4				
	Gas (Flare)	ø 12.7				
	Drain	VP25 (External Dia, 32/Internal Dia, 25)				

MODEL		FXMQ63PBV36	FXMQ80PBV36	FXMQ100PBV36	FXMQ125PBV36	FXMQ140PBV36
Power supply		1-phase, 220-240 V/220 V, 50 Hz				
Cooling capacity	Btu/h	24,200	30,700	38,200	47,800	54,600
	kW	7.1	9.0	11.2	14.0	16.0
Heating capacity	Btu/h	27,300	34,100	42,700	54,600	61,400
	kW	8.0	10.0	12.5	16.0	18.0
Casing		Galvanised steel plate				
Airflow rate (HH/H/L)	m <sup>3</sup> /min	19.5/17.5/16	25/22.5/20	32/27/23	39/33/28	46/39/32
	cfm	688/618/565	883/794/706	1,130/953/812	1,377/1,165/988	1,624/1,377/1,130
External static pressure	Pa	50-200 (100) * <sup>2</sup>			50-200 (100) * <sup>2</sup>	50-140 (100) * <sup>2</sup>
Sound level (HH/H/L)	dBA	42/40/38	43/41/39	43/41/39	44/42/40	46/45/43
Dimensions (HxWxD)	mm	300x1,000x700		300x1,400x700		
Machine weight	kg	35		45	46	
Piping connections	Liquid (Flare)	9.5				
	Gas (Flare)	15.9				
	Drain	VP25 (External Dia, 32/Internal Dia, 25)				

**Note: Specifications are based on the following conditions**

- Cooling: Indoor temp.: 27°CDB, 19°CWB, Outdoor temp.: 35°CDB, Equivalent piping length: 7.5 m, Level difference: 0 m.
- Heating: Indoor temp.: 20°CDB, Outdoor temp.: 7°CDB, 6°CDB Equivalent piping length: 7.5 m, Level difference: 0 m.
- Capacity of indoor unit is only for reference. Actual capacity of indoor unit is based on the total capacity index.
- Sound level: Anechoic chamber conversion value, measured at a point 1.5 m downward from the unit centre.  
During actual operation, these values are normally somewhat higher as a result of ambient conditions.
- ★ 1: Power consumption values are based on conditions of rated external static pressure.
- ★ 2: External static pressure can be modified using a remote controller that offers seven (FXMQ20-32P), thirteen (FXMQ40P), fourteen (FXMQ50-125P) or ten (FXMQ140P) levels of control. These values indicate the lowest and highest possible static pressures. The standard static pressure is 50 Pa for FXMQ20-32P and 100 Pa for FXMQ40-140P.

## VRV Indoor Units

### Ceiling Mounted Duct Type



MODEL		FXMQ170NVE6	FXMQ200NVE6	FXMQ250NVE6
Power supply		1-phase, 220, 240 V/220 V, 50 Hz		
Cooling capacity	Btu/h	65,800	76,400	95,500
	kW	19.3	22.4	28
Heating capacity	Btu/h	71,600	83,300	1,07,500
	kW	21	25	31.5
Casing		Galvanised steel plate		
Airflow rate (H/L)	m <sup>3</sup> /min	58/50	68/58	80/73
	cfm	2,047/1,765	2400/2,047	2,825/2,578
External static pressure	Pa	100-140 *2	100-200 *2	190-270 *2
Sound level (H/L) 220V	dBA	45/42	47/45	49/47
Dimensions (HxWxD)	mm	440x1,190x1,090		440x1,490x1,090
Machine weight	kg	110		130
Piping connections	Liquid (Flare)	ø 9.5		
	Gas (Flare)	ø 19.1		ø 22.2
	Drain	External Dia 32		

### Ceiling Suspended Type



MODEL		FXHQ32MAVE	FXHQ63MAVE	FXHQ100MAVE	FXHQ125AVM	FXHQ140AVM
Power supply		1-phase, 220-240 V/220 V, 50/60 Hz			1-phase, 220-240 V/220-230 V, 50/60 Hz	
Cooling capacity	Btu/h	12,300	24,200	38,200	48,000	52,900
	kW	3.6	7.1	11.2	14.1	15.5
Heating capacity	Btu/h	13,600	27,300	42,700	54,600	58,000
	kW	4.0	8.0	12.5	16.0	17.0
Airflow rate (H/M/L)	m <sup>3</sup> /min	12/-/10	17.5/-/14	25/-/19.5	34/26/20	36/27/20
	cfm	424/-/353	618/-/494	883/-/688	1,200/918/706	1,271/953/706
Sound level (H/M/L)	dBA	36/-/31	39/-/34	45/-/37	46/41/37	48/42/37
Dimensions (HxWxD)	mm	195x960x680	195x1,160x680	195x1,400x680	235x1,590x690	
Machine weight	kg	24	28	33	41	
Piping connections	Liquid (Flare)	ø 6.4	ø 9.5			
	Gas (Flange)	ø 12.7	ø 15.9			
	Drain	VP20 (External Dia. 26/Internal Dia. 20)				

**Note: Specifications are based on the following conditions**

- Cooling: Indoor temp.: 27°CDB, 19°CWB, Outdoor temp.: 35°CDB, Equivalent piping length: 7.5 m, Level difference: 0 m.
- Heating: Indoor temp.: 20°CDB, Outdoor temp.: 7°CDB, 6°CDB Equivalent piping length: 7.5 m, Level difference: 0 m.
- Capacity of indoor unit is only for reference. Actual capacity of indoor unit is based on the total capacity index.
- Sound level: (FXMQ-MA) Anechoic chamber conversion value, measured at a point 1.5 m downward from the unit centre. (FXHQ-MA) Anechoic chamber conversion value, measured at a point 1 m in front of the unit and 1 m downward. During actual operation, these values are normally somewhat higher as a result of ambient conditions.
- \* 1: Power consumption values are based on conditions of standard external static pressure.
- \* 2: External static pressure is changeable to change over the connectors inside electrical box, this pressure means "Standard-High static pressure".

## 4-way Flow Ceiling Suspended Type



MODEL		FXUQ71AVEB	FXUQ100AVEB
Power supply		1-phase, 220-240 V/220-230V, 50 Hz	
Cooling capacity	Btu/h	27,300	38,200
	kW	8.0	11.2
Heating capacity	Btu/h	30,700	42,700
	kW	9.0	12.5
Casing		Fresh white	
Airflow rate (H/L)	m <sup>3</sup> /min	22.5/19.5/16	31/26/21
	cfm	794/688/565	1,094/918/741
Sound level (H/M//L)		40/38/36	47/44/40
Dimensions (HxWxD)		198x950x950	
Machine weight		26	27
Piping connections	Liquid (Flare)	9.5	
	Gas (Flare)	15.9	
	Drain	VP20 (External Dia, 26/Internal Dia, 20)	

- Cooling: Indoor temp.: 27°CDB, 19°CWB, Outdoor temp.: 35°CDB, Equivalent piping length: 7.5 m, Level difference: 0 m.
- Heating: Indoor temp.: 20°CDB, Outdoor temp.: 7°CDB, 6°CDB Equivalent piping length: 7.5 m, Level difference: 0 m.
- Capacity of indoor unit is only for reference. Actual capacity of indoor unit is based on the total capacity index.
- Sound level: Anechoic chamber conversion value, measured at a point 1.5 m downward from the unit centre.  
During actual operation, these values are normally somewhat higher as a result of ambient conditions.

## Wall Mounted Type



MODEL		FXAQ20ARVE6	FXAQ25ARVE6	FXAQ32ARVE6	FXAQ40ARVE6	FXAQ50ARVE6	FXAQ63ARVE6
Power supply		1-phase, 220 V/220 V, 50 Hz					
Cooling capacity	Btu/h	7,500	9,600	12,300	15,400	19,100	24,200
	kW	2.2	2.8	3.6	4.5	5.6	7.1
Heating capacity	Btu/h	8,500	10,900	13,600	17,100	21,500	27,300
	kW	2.5	3.2	4.0	5.0	6.3	8.0
Casing		White (N9.5)					
Airflow rate (H/L)	m <sup>3</sup> /min	7.5/4.5	9/5	11/5.5	13/9	15/12	19/14
	cfm	265/159	318/177	388/194	459/318	530/424	671/494
Sound level (H/L)		35/31	36/31	38/31	39/34	42/37	47/41
Dimensions (HxWxD)		298x929x258					
Machine weight		13.0					
Piping connections	Liquid (Flare)	ø 6.4					ø 9.5
	Gas (Flare)	ø 12.7					ø 15.9
	Drain	VP13 (External Dia, 18/Internal Dia, 13)					

## VRV Indoor Units

### Floor Standing Type/Concealed Floor Standing Type



FXLQ



FXNQ

MODEL		FXLQ32MAVE8	FXLQ50MAVE8	FXLQ63MAVE8
		FXNQ32MAVE8	FXNQ50MAVE8	FXNQ63MAVE8
Power supply		1-phase, 220-240 V/220 V, 50 Hz		
Cooling capacity	Btu/h	12,300	19,100	24,200
	kW	3.6	5.6	7.1
Heating capacity	Btu/h	13,600	21,500	27,300
	kW	4.0	6.3	8.0
Casing		FXLQ: Ivory white (5Y7.5/1)/FXNQ: Galvanised steel plate		
Airflow rate (H/L)	m <sup>3</sup> /min	8/6	14/11	16/12
	cfm	282/212	494/388	565/424
Sound level (H/L) 220V	dBA	35/32	39/34	40/35
Dimensions (HxWxD)	FXLQ	600x1,140x222	600x1,420x222	600x1,420x222
	FXNQ	610x1,070x220	610x1,350x220	610x1,350x220
Machine weight	FXLQ	30.0	36.0	36.0
	FXNQ	23.0	27.0	27.0
Piping connections	Liquid (Flare)	ø 6.4	ø 6.4	ø 9.5
	Gas (Flare)	ø 12.7	ø 12.7	ø 15.9
	Drain	21O.D.		

Note: Specifications are based on the following conditions:

- Cooling: Indoor temp.: 27°CDB, 19°CWB, Outdoor temp.: 35°CDB, Equivalent piping length: 7.5 m, Level difference: 0 m.
- Heating: Indoor temp.: 20°CDB, Outdoor temp.: 7°CDB, 6°CDB Equivalent piping length: 7.5 m, Level difference: 0 m.
- Capacity of indoor unit is only for reference. Actual capacity of indoor unit is based on the total capacity index.
- Sound level: (FXAQ-P) Anechoic chamber conversion value, measured at a point 1 m in front of the unit and 1 m downward. (FXLQ-MA, FXNQ-MA) Anechoic chamber conversion value, measured at a point 1.5 m in front of the unit at a height of 1.5 m. During actual operation, these values are normally somewhat higher as a result of ambient conditions.

### Floor Standing Duct Type



MODEL		FXVQ125NY1	FXVQ200NY1	FXVQ250NY1	FXVQ400NY1	FXVQ500NY16
Power supply		3-phase 4-wire system, 380 -415 V, 50 Hz				
Cooling capacity	Btu/h	47,800	76,400	95,500	1,54,000	1,91,000
	kW	14.0	22.4	28.0	45.0	56.0
Heating capacity	Btu/h	54,600	85,300	1,07,500	1,71,000	2,15,000
	kW	16.0	25.0	31.5	50.0	63.0
Casing colour		Ivory white (5Y7.5/1)				
Dimensions (HxWxD)	mm	1670x750x510	1670x950x510	1670x1170x510	1900x1170x720	1900x1470x720
Machine weight	kg	118	144	169	236	306
Airflow rate	m <sup>3</sup> /min	43	69	86	134	172
	cfm	1,518	2,436	3,036	4,730	6,072
External static Pressure*2	Pa	152	217	281	420	390
Drive system		Belt drive system				
Air Filter	Type	Long-life filter (anti-mould resin net)				
Sound level *1	dBA	52	56	60	65	66
Piping connections	Liquid (Flare)	9.5 (Brazeing)			12.7 (Brazeing)	15.9 (Brazeing)
	Gas (Flare)	15.9 (Brazeing)	19.1 (Brazeing)	22.2 (Brazeing)	28.6 (Brazeing)	
	Drain	Rp1 (PS 1B internal thread)				

Note: Specifications are based on the following conditions:

- Cooling: Indoor temp. of 27°CDB, 19°CWB, and outdoor temp. of 35°CDB.
- Heating: Indoor temp.: 20°CDB, Outdoor temp.: 7°CDB, 6°CDB Equivalent piping length: 7.5 m, Level difference: 0 m.
- Capacity of indoor unit is only for reference. Actual capacity of indoor unit is based on the total capacity index.
- \* 1: Sound level: measured when the air discharge outlet duct (2 m) is attached (anechoic chamber conversion value). It increases by approximately 5 dBA when the plenum chamber is installed to deliver direct airflow.
- \* 2: The value is the external static pressure with standard pulley.

## Clean Room Type Air Conditioner



Type		Integrated outlet unit model			Separate outlet unit model
MODEL	Indoor unit	FXBQ40PVE	FXBQ50PVE	FXBQ63PVE	FXBPQ63PVE
	Outlet unit	Integrated with the indoor unit			BAF82A63
Power supply		1-phase, 220-240 V/220 V, 50/60 Hz			
Cooling capacity	Btu/h	15,400	19,100	24,200	24,200
	kW	4.5	5.6	7.1	7.1
Power consumption	kW	0.31	0.31	0.45	0.45
Intake filter efficiency *1	70% by gravimetric method				
Outlet HEPA filter efficiency *2	99.97% by DOP method *5				
Indoor unit weight	kg	140 *3		185 *3	120 *6
Casing		Galvanised steel plate			
Airflow rate (H/L)	cfm	19.5/17.5		26/22.5	
	m <sup>3</sup> /min	688/618		918/794	
Dimensions (HxWxD)	mm	492x1,788x1,000		492x1,788x1,300	492x1,078x1,300
Outlet unit weight	kg	-			65 *3
Piping connections	Liquid (Flare)	ø6.4		ø9.5	
	Gas (Flare)	ø12.7		ø15.9	
	Drain	PT1B			
Filter(Optional)	HEPA filter	BAFH82A50		BAFH82A63	
Panel (Option)	Ceiling intake type	BYB82A50C		BYB82A63C	BYB82A63CP
	Floor-level intake type	BYB82A50W		BYB82A63W	BYB82A63WP

**Note: Specifications are based on the following conditions:**

- Cooling: Indoor temp.: 27°CDB, 19°CWB, Outdoor temp.: 35°CDB, Equivalent piping length: 7.5 m, Level difference: 0 m.
- Capacity of indoor unit is only for reference. Actual capacity of indoor unit is based on the total capacity index. (See Engineering Data Book for details.)
- \*1: An intake air filter is only attached to the ceiling intake type.
- \*2: HEPA filter sold separately. The dust collection efficiency of HEPA filter is 99.97%. However, air may slightly leak around the filter when installing.
- \*3: Weight including HEPA filter and panel.
- \*4: Anechoic chamber conversion value under JIS B 8616 test conditions. Value usually increases slightly in practice due to surrounding conditions.
- \*5: The clean room air conditioner does not support DOP testing (leak test) based on GMP standards (Standards for Manufacturing Control and Quality Control for Medical Devices) due to slight leakage at time of product installation.
- \*6: Weight including panel.

\*In the case of an installation in an operating theatre etc. where an air conditioner malfunction may have serious consequences, please build in redundancy with two or more outdoor units.

## Multi Cube (Spot AC) type



MODEL		FXPQ25AVM	
Power Supply		1 Phase, 50Hz, 220-240 V	
Capacity (watt)	Cooling	2800	
	Heating	3200	
Dimension	(HXWXD) mm	455X555X470	
Casing		Galvanised Steel plate	
Fan	Type		Propeller Fan
	Airflow Rate (H/L)	CMH	13.5 / 11.0
		CFM	477 / 393
	External Static Pressure	PA	5
	Drive	Direct Drive	
Sound Level	dB(A)	51	
Machine Weight	Kg	30	
Piping Connections	Liquid Pipe	mm	6.4mm dia (Flare Connection)
	Gas Pipe	mm	12.7mm dia (Flare Connection)
	Drain Pipe	mm	(External dia 27.2mm, internal dia 21.6mm)
Refrigerant Control	Electronic Expansion Valve		
Air Filter	Long Life Filter (Resin Net)		

## Outdoor Units

### VRV X (Cooling Only)

								
MODEL			RXQ6ARY6(ES)	RXQ8ARY6(ES)	RXQ10ARY6(ES)	RXQ12ARY6(ES)	RXQ14ARY6(ES)	RXQ16ARY6(ES)
Combination units			—	—	—	—	—	—
Power supply			3-phase, 380-415 V, 50 Hz					
Cooling capacity	Btu/h		54,600	76,400	95,500	1,14,000	1,36,000	1,54,000
	kW		16.0	22.4	28.0	33.5	40.0	45.0
Capacity control	%		25~100	20~100	13~100	12~100	11~100	10~100
Casing colour			Ivory white (5Y7.5/1)					
Compressor	Type		Hermetically Sealed Scroll Type					
	No. of compressor		1	1	1	1	1	2
Airflow rate	m <sup>3</sup> /min		119	178		191	257	
Dimensions (HxWxD)	mm		1,657X930X765				1,657X1,240X765	
Machine weight	kg		165		175		220	260
Sound level	dBA		56	56	57	59	60	60
Operation range	Cooling	°CDB	10 ~ 49					
Refrigerant	Type		R410A					
	Charge	kg	5.9		6.7	6.8	7.4	8.2
Piping connections	Liquid	mm	ø 9.5			ø 12.7		
	Gas	mm	ø 19.1		ø 22.2	ø 28.6		

**Note:** Specifications are based on the following conditions:

- Cooling: Indoor temp.: 27°CDB, 19°CWB, Outdoor temp.: 35°CDB, Equivalent piping length: 7.5 m, Level difference: 0
- Sound level: Anechoic chamber conversion value, measured at a point 1 m in front of the unit at a height of 1.5 m.  
During actual operation, these values are normally somewhat higher as a result of ambient conditions.
- (ES) for anticorrosion treated outdoor unit.

## VRV X (Cooling Only)

<b>MODEL</b>			<b>RXQ18ARY6(ES)</b>	<b>RXQ20ARY6(ES)</b>	<b>RXQ22ARY6(ES)</b>	<b>RXQ24ARY6(ES)</b>
<b>Combination units</b>			—	—	<b>RXQ10ARY6(ES)</b>	<b>RXQ12ARY6(ES)</b>
			—	—	<b>RXQ12ARY6(ES)</b>	<b>RXQ12ARY6(ES)</b>
			—	—	—	—
Power supply			3-phase, 380–415 V, 50 Hz			
Cooling capacity		Btu/h	1,71,000	1,91,000	2,10,000	2,29,000
		kW	50.0	56.0	61.5	67.0
Capacity control		%	10~100	7~100	6~100	
Casing colour			Ivory white (5Y7.5/1)			
Compressor		Type	Hermetically Sealed Scroll Type			
		No. of compressor	2	2	1+1	1+1
Airflow rate		m <sup>3</sup> /min	257	297	178+191	191+191
Dimensions (HxWxD)		mm	1,657X1,240X765		(1,657X930X765)+(1,657X930X765)	
Machine weight		kg	260	285	175+175	
Sound level		dB(A)	61	65	61	62
Operation range		Cooling °CDB	10 ~ 49			
Refrigerant		Type	R410A			
		Charge	kg	8.4	11.8	6.7+6.8
Piping connections		Liquid	mm			
		Gas	mm		mm	
			ø 15.9		ø 28.6      ø 34.9	

**Note: Specifications are based on the following conditions:**

- Cooling: Indoor temp.: 27°CDB, 19°CWB, Outdoor temp.: 35°CDB, Equivalent piping length: 7.5 m, Level difference: 0 m.
- Sound level: Anechoic chamber conversion value, measured at a point 1 m in front of the unit at a height of 1.5 m. During actual operation, these values are normally somewhat higher as a result of ambient conditions.
- (ES) for anticorrosion treated outdoor unit.

## Outdoor Units

### VRV X (Cooling Only)

<b>MODEL</b>			<b>RXQ26ARY6(ES)</b>	<b>RXQ28ARY6(ES)</b>	<b>RXQ30ARY6(ES)</b>	<b>RXQ32ARY6(ES)</b>	<b>RXQ34ARY6(ES)</b>	<b>RXQ36ARY6(ES)</b>	
<b>Combination units</b>			<b>RXQ12ARY6(ES)</b>	<b>RXQ12ARY6(ES)</b>	<b>RXQ12ARY6(ES)</b>	<b>RXQ14ARY6(ES)</b>	<b>RXQ16ARY6(ES)</b>	<b>RXQ18ARY6(ES)</b>	
			<b>RXQ14ARY6(ES)</b>	<b>RXQ16ARY6(ES)</b>	<b>RXQ18ARY6(ES)</b>	<b>RXQ18ARY6(ES)</b>	<b>RXQ18ARY6(ES)</b>	<b>RXQ18ARY6(ES)</b>	
			—	—	—	—	—	—	
Power supply			3-phase, 380–415 V, 50 Hz						
Cooling capacity		Btu/h	2,47,000	2,68,000	2,85,000	3,05,000	3,24,000	3,41,000	
		kW	73.5	78.5	83.5	90	95.0	100	
Capacity control	%	6~100	5~100	5~100	5~100	4~100	5~100		
Casing colour			Ivory white (5Y7.5/1)						
Compressor		Type	Hermetically Sealed Scroll Type						
		No. of compressors	1+1	1+2	1+2	1+2	2+2	2+2	
Airflow rate		m <sup>3</sup> /min	191+257	191+257	191+257	257+257	257+257	257+257	
Dimensions (HxWxD)		mm	(1,657X930X765)+(1,657X1,240X765)			(1,657X1,240X765)+(1,657X1,240X765)			
Machine weight		kg	175+220	175+260		220+260	260+260		
Sound level		dBA	63			64			
Operation range	Cooling	°CDB	10 ~ 49						
Refrigerant		Type	R410A						
		Charge	kg	6.8+7.4	6.8+8.2	6.8+8.4	7.4+8.4	8.2+8.4	8.4+8.4
Piping connections		Liquid	mm	ø 19.1	ø 19.1	ø 19.1	ø 19.1	ø 19.1	ø 19.1
		Gas	mm	ø 34.9	ø 34.9	ø 34.9	ø 34.9	ø 34.9	ø 41.3

**Note: Specifications are based on the following conditions:**

- Cooling: Indoor temp.: 27°CDB, 19°CWB, Outdoor temp.: 35°CDB, Equivalent piping length: 7.5m, Level difference: 0m.
- Sound level: Anechoic chamber conversion value, measured at a point 1m in front of the unit at a height of 1.5m.  
During actual operation, these values are normally somewhat higher as a result of ambient conditions.
- (ES) for anticorrosion treated outdoor unit.

## VRV X (Cooling Only)

RXQ38ARY6(ES)	RXQ40ARY6(ES)	RXQ42ARY6(ES)	RXQ44ARY6(ES)	RXQ46ARY6(ES)	RXQ48ARY6(ES)	RXQ50ARY6(ES)
RXQ18ARY6(ES)	RXQ20ARY6(ES)	RXQ12ARY6(ES)	RXQ12ARY6(ES)	RXQ14ARY6(ES)	RXQ14ARY6(ES)	RXQ14ARY6(ES)
RXQ20ARY6(ES)	RXQ20ARY6(ES)	RXQ12ARY6(ES)	RXQ12ARY6(ES)	RXQ14ARY6(ES)	RXQ16ARY6(ES)	RXQ18ARY6(ES)
—	—	RXQ18ARY6(ES)	RXQ20ARY6(ES)	RXQ18ARY6(ES)	RXQ18ARY6(ES)	RXQ18ARY6(ES)
3-phase, 380-415 V, 50 Hz						
3,62,000	3,82,000	3,99,000	4,20,000	4,40,000	4,57,000	4,78,000
106	112	117	123	129	134	140
4~100		3~100		4~100	3~100	
Ivory white (5Y7.5/1)						
Hermetically Sealed Scroll Type						
2+2		1+1+2			1+2+2	
257+297	297+297	191+191+257	191+191+297	257+257+257		
(1,657X1,240X765)+ (1,657X1,240X765)		(1,657X930X765)+ (1,657X930X765)+ (1,657X1,240X765)		(1,657X1,240X765)+ (1,657X1,240X765)+ (1,657X1,240X765)		
260+285	285+285	175+175+260	175+175+285	220+220+260	220+260+260	220+260+260
66	68	65	67	65		
10 ~ 49						
R410A						
8.4+11.8	11.8+11.8	6.8+6.8+8.4	6.8+6.8+11.8	7.4+7.4+11.8	7.4+8.2+8.4	7.4+8.4+8.4
Ø 19.1						
Ø 41.3						

**Note: Specifications are based on the following conditions:**

- Cooling: Indoor temp.: 27°CDB, 19°CWB, Outdoor temp.: 35°CDB, Equivalent piping length: 7.5m, Level difference: 0m.
- Sound level: Anechoic chamber conversion value, measured at a point 1m in front of the unit at a height of 1.5m.  
During actual operation, these values are normally somewhat higher as a result of ambient conditions.
- (ES) for anticorrosion treated outdoor unit.

## Outdoor Units



### VRV X (Cooling Only)

							
<b>MODEL</b>			<b>RXQ52ARY6(ES)</b>	<b>RXQ54ARY6(ES)</b>	<b>RXQ56ARY6(ES)</b>	<b>RXQ58ARY6(ES)</b>	<b>RXQ60ARY6(ES)</b>
<b>Combination units</b>			<b>RXQ16ARY6(ES)</b>	<b>RXQ18ARY6(ES)</b>	<b>RXQ18ARY6(ES)</b>	<b>RXQ18ARY6(ES)</b>	<b>RXQ20ARY6(ES)</b>
			<b>RXQ18ARY6(ES)</b>	<b>RXQ18ARY6(ES)</b>	<b>RXQ18ARY6(ES)</b>	<b>RXQ20ARY6(ES)</b>	<b>RXQ20ARY6(ES)</b>
			<b>RXQ18ARY6(ES)</b>	<b>RXQ18ARY6(ES)</b>	<b>RXQ20ARY6(ES)</b>	<b>RXQ20ARY6(ES)</b>	<b>RXQ20ARY6(ES)</b>
<b>Power supply</b>			3-phase, 380–415 V, 50 Hz				
<b>Cooling capacity</b>	<b>Btu/h</b>		4,95,000	5,12,000	5,32,000	5,53,000	5,73,000
		<b>kW</b>	145	150	156	162	168
<b>Capacity control</b>	<b>%</b>		3~100			2~100	
<b>Casing colour</b>			Ivory white (5Y7.5/1)				
<b>Compressor</b>	<b>Type</b>		Hermetically Sealed Scroll Type				
	<b>No. of compressors</b>		2+2+2				
<b>Airflow rate</b>		<b>m<sup>3</sup>/min</b>	257+257+257			257+297+297	
<b>Dimensions (HxWxD)</b>		<b>mm</b>	(1,657X1,240X765 + 1,657X1,240X765 + 1,657X1,240X765)				
<b>Machine weight</b>		<b>kg</b>	260+260+260		260+260+285	260+285+285	285+285+285
<b>Sound level</b>		<b>dBA</b>	65	66	68	69	70
<b>Operation range</b>	<b>Cooling</b>	<b>°CDB</b>	10 ~ 49				
<b>Refrigerant</b>	<b>Type</b>		R410A				
	<b>Charge</b>	<b>kg</b>	8.2+8.4+8.4	8.4+8.4+8.4	8.4+8.4+11.8	8.4+11.8+11.8	11.8+11.8+11.8
<b>Piping connections</b>	<b>Liquid</b>	<b>mm</b>	ø 19.1				
	<b>Gas</b>	<b>mm</b>	ø 41.3				

**Note: Specifications are based on the following conditions:**

- Cooling: Indoor temp.: 27°CDB, 19°CWB, Outdoor temp.: 35°CDB, Equivalent piping length: 7.5m, Level difference: 0m.
- Sound level: Anechoic chamber conversion value, measured at a point 1m in front of the unit at a height of 1.5m.  
During actual operation, these values are normally somewhat higher as a result of ambient conditions.
- (ES) for anticorrosion treated outdoor unit.

## VRV X (Heat Pump)



							
MODEL		RXYQ6ARY6	RXYQ8ARY6	RXYQ10ARY6	RXYQ12ARY6	RXYQ14ARY6	RXYQ16ARY6
Combination units		—	—	—	—	—	—
Power supply		3-phase, 380-415 V, 50 Hz					
Cooling capacity	Btu/h	54,600	76,400	95,500	1,14,000	1,36,000	1,54,000
	kW	16.0	22.4	28.0	33.5	40.0	45.0
Heating capacity	Btu/h	61,400	85,300	1,07,000	1,28,000	1,54,000	1,71,000
	kW	18.0	25.0	31.5	37.5	45.0	50.0
Capacity control	%	25-100	20-100	13-100	12-100	11-100	10-100
Casing colour		Ivory white (5Y7.5/1)					
Compressor	Type	Hermetically Sealed Scroll Type					
	No. of compressors	1				2	
Airflow rate	m <sup>3</sup> /min	119	178		191	257	
Dimensions (HxWxD)	mm	1,657X930X765				1,657X1,240X765	
Machine weight	kg	180		195		265	
Sound level	dB(A)	56		57		60	
Operation range	Cooling	°CDB		-5 ~ 49			
	Heating	°CWB		-20 ~ 15.5			
Refrigerant	Type	R410A					
	Charge	kg	6.9	7.0	7.4	7.6	9.1
Piping connections	Liquid	mm	ø 9.5			ø 12.7	
	Gas	mm	ø 19.1		ø 22.2	ø 28.6	

**Note: Specifications are based on the following conditions:**

- Cooling: Indoor temp.: 27°CDB, 19°CWB, Outdoor temp.: 35°CDB, Equivalent piping length: 7.5m, Level difference: 0.
- Heating: Indoor temp.: 20°CDB, Outdoor temp.: 7°CDB, 6°CWB, Equivalent piping length: 7.5m, Level difference: 0m.
- Sound level: Anechoic chamber conversion value, measured at a point 1m in front of the unit at a height of 1.5m. During actual operation, these values are normally somewhat higher as a result of ambient conditions.

## Outdoor Units

### VRV X (Heat Pump)

						
<b>MODEL</b>			<b>RXYQ18ARY6</b>	<b>RXYQ20ARY6</b>	<b>RXYQ22ARY6</b>	<b>RXYQ24ARY6</b>
<b>Combination units</b>			—	—	<b>RXYQ10ARY6</b>	<b>RXYQ12ARY6</b>
			—	—	<b>RXYQ12ARY6</b>	<b>RXYQ12ARY6</b>
			—	—	—	—
Power supply			3-phase, 380–415 V, 50 Hz			
Cooling capacity	Btu/h		1,71,000	1,91,000	2,10,000	2,29,000
	kW		50.0	56.0	61.5	67.0
Heating capacity	Btu/h		1,91,000	2,15,000	2,35,000	2,56,000
	kW		56.0	63.0	69.0	75.0
Capacity control	%		10-100	7-100	6-100	
Casing colour			Ivory white (5Y7.5/1)			
Compressor	Type		Hermetically Sealed Scroll Type			
	No. of compressors		2		1+1	
Airflow rate	m <sup>3</sup> /min		257	297	178+191	191+191
Dimensions (HxWxD)	mm		1,657X1,240X765		(1,657X930X765)+(1,657X930X765)	
Machine weight	kg		285	305	195+195	
Sound level	dBA		61	65	61	62
Operation range	Cooling	°CDB	-5 ~ 49			
	Heating	°CWB	-20 ~ 15.5			
Refrigerant	Type		R410A			
	Charge	kg	11.8		7.4+7.6	7.6+7.6
Piping connections	Liquid	mm	ø 15.9			
	Gas	mm	ø 28.6			ø 34.9

**Note: Specifications are based on the following conditions:**

- Cooling: Indoor temp.: 27°CDB, 19°CWB, Outdoor temp.: 35°CDB, Equivalent piping length: 7.5m, Level difference: 0.
- Heating: Indoor temp.: 20°CDB, Outdoor temp.: 7°CDB, 6°CWB, Equivalent piping length: 7.5m, Level difference: 0m.
- Sound level: Anechoic chamber conversion value, measured at a point 1m in front of the unit at a height of 1.5m.  
During actual operation, these values are normally somewhat higher as a result of ambient conditions.

## VRV X (Heat Pump)



<b>MODEL</b>			<b>RXYQ26ARY6</b>	<b>RXYQ28ARY6</b>	<b>RXYQ30ARY6</b>	<b>RXYQ32ARY6</b>	<b>RXYQ34ARY6</b>	<b>RXYQ36ARY6</b>
<b>Combination units</b>			<b>RXYQ12ARY6</b>	<b>RXYQ12ARY6</b>	<b>RXYQ12ARY6</b>	<b>RXYQ16ARY6</b>	<b>RXYQ16ARY6</b>	<b>RXYQ16ARY6</b>
			<b>RXYQ14ARY6</b>	<b>RXYQ16ARY6</b>	<b>RXYQ18ARY6</b>	<b>RXYQ16ARY6</b>	<b>RXYQ18ARY6</b>	<b>RXYQ20ARY6</b>
			—	—	—	—	—	—
Power supply			3-phase, 380-415 V, 50 Hz					
Cooling capacity		Btu/h	2,47,000	2,68,000	2,85,000	3,05,000	3,24,000	3,45,000
		kW	73.5	78.5	83.5	90.0	95.0	101.0
Heating capacity		Btu/h	—	2,99,000	3,19,000	3,41,000	3,62,000	3,86,000
		kW	82.5	87.5	93.5	100.0	106.0	113.0
Capacity control		%	5-100					4-100
Casing colour			Ivory white (5Y7.5/1)					
Compressor		Type	Hermetically Sealed Scroll Type					
		No. of compressors	1+2			2+2		
Airflow rate		m <sup>3</sup> /min	191+257			257+257		257+297
Dimensions (HxWxD)		mm	(1,657X930X765)+(1,657X1,240X765)			(1,657X1,240X765)+(1,657X1,240X765)		
Machine weight		kg	195+265		195+285	265+265	265+285	265+305
Sound level		dB(A)	63				64	66
Operation range		Cooling	°CDB		-5 ~ 49			
		Heating	°CWB		-20 ~ 15.5			
Refrigerant		Type		R410A				
		Charge	kg	7.6+9.1	7.6+9.3	7.6+11.8	9.3+9.3	9.3+11.8
Piping connections		Liquid	mm		ø 19.1			
		Gas	mm		ø 34.9			

**Note: Specifications are based on the following conditions:**

- Cooling: Indoor temp.: 27°CDB, 19°CWB, Outdoor temp.: 35°CDB, Equivalent piping length: 7.5m, Level difference: 0.
- Heating: Indoor temp.: 20°CDB, Outdoor temp.: 7°CDB, 6°CWB, Equivalent piping length: 7.5m, Level difference: 0m.
- Sound level: Anechoic chamber conversion value, measured at a point 1m in front of the unit at a height of 1.5m.  
During actual operation, these values are normally somewhat higher as a result of ambient conditions.

## Outdoor Units

### VRV X (Heat Pump)

					
<b>MODEL</b>		<b>RXYQ38ARY6</b>	<b>RXYQ40ARY6</b>	<b>RXYQ42ARY6</b>	<b>RXYQ44ARY6</b>
<b>Combination units</b>		<b>RXYQ18ARY6</b>	<b>RXYQ20ARY6</b>	<b>RXYQ12ARY6</b>	<b>RXYQ12ARY6</b>
		<b>RXYQ20ARY6</b>	<b>RXYQ20ARY6</b>	<b>RXYQ12ARY6</b>	<b>RXYQ12ARY6</b>
		—	—	<b>RXYQ18ARY6</b>	<b>RXYQ20ARY6</b>
<b>Power supply</b>		3-phase, 380–415 V, 50 Hz			
<b>Cooling capacity</b>	Btu/h	3,62,000	3,82,000	3,99,000	4,20,000
	kW	106.0	112.0	117.0	123.0
<b>Heating capacity</b>	Btu/h	4,06,000	4,30,000	4,47,000	4,71,000
	kW	119.0	126.0	131.0	138.0
<b>Capacity control</b>	%	4 - 100	3 - 100	4 - 100	3 - 100
<b>Casing colour</b>		Ivory white (5Y7.5/1)			
<b>Compressor</b>	Type	Hermetically Sealed Scroll Type			
	No. of compressors	2+2		1+1+2	
<b>Airflow rate</b>	m <sup>3</sup> /min	257+297	297+297	191+191+257	191+191+297
<b>Dimensions (HxWxD)</b>	mm	(1,657X1,240X765)+ (1,657X1,240X765)		(1,657X930X765)+ (1,657X930X765)+ (1,657X1,240X765)	
<b>Machine weight</b>	kg	285+305	305+305	195+195+285	200+200+325
<b>Sound level</b>	dBA	66	68	65	67
<b>Operation range</b>	Cooling	°CDB -5 ~ 49			
	Heating	°CWB -20 ~ 15.5			
<b>Refrigerant</b>	Type	R410A			
	Charge	kg	11.8+11.8		7.6+7.6+11.8
<b>Piping connections</b>	Liquid	mm	Ø 19.1		
	Gas	mm	Ø 41.3		

**Note: Specifications are based on the following conditions:**

- Cooling: Indoor temp.: 27°CDB, 19°CWB, Outdoor temp.: 35°CDB, Equivalent piping length: 7.5m, Level difference: 0.
- Heating: Indoor temp.: 20°CDB, Outdoor temp.: 7°CDB, 6°WB, Equivalent piping length: 7.5m, Level difference: 0m.
- Sound level: Anechoic chamber conversion value, measured at a point 1m in front of the unit at a height of 1.5m.  
During actual operation, these values are normally somewhat higher as a result of ambient conditions.

## VRV X (Heat Pump)

RXYQ46ARY6	RXYQ48ARY6	RXYQ50ARY6	RXYQ52ARY6	RXYQ54ARY6	RXYQ56ARY6	RXYQ58ARY6	RXYQ60ARY6	
RXYQ14ARY6	RXYQ16ARY6	RXYQ16ARY6	RXYQ16ARY6	RXYQ18ARY6	RXYQ18ARY6	RXYQ18ARY6	RXYQ20ARY6	
RXYQ16ARY6	RXYQ16ARY6	RXYQ16ARY6	RXYQ18ARY6	RXYQ18ARY6	RXYQ18ARY6	RXYQ20ARY6	RXYQ20ARY6	
RXYQ16ARY6	RXYQ16ARY6	RXYQ18ARY6	RXYQ18ARY6	RXYQ18ARY6	RXYQ20ARY6	RXYQ20ARY6	RXYQ20ARY6	
3-phase, 380-415 V, 50 Hz								
4,44,000	4,61,000	4,78,000	4,95,000	5,12,000	5,32,000	5,53,000	5,73,000	
130.0	135.0	140.0	145.0	150.0	156.0	162.0	168.0	
4,95,000	5,12,000	5,32,000	5,53,000	5,73,000	5,97,000	6,21,000	6,45,000	
145.0	150.0	156.0	162.0	168.0	175.0	182.0	189.0	
3 - 100						2 - 100		
Ivory white (5Y7.5/1)								
Hermetically Sealed Scroll Type								
2+2+2								
257+257+257		257+257+257		257+257+257		257+257+297	257+297+297	297+297+297
(1,657X1,240X765)+ (1,657X1,240X765)+ (1,657X1,240X765)			(1,657X1,240X765 + 1,657X1,240X765 + 1,657X1,240X765)					
195+195+305	265+265+265	265+265+285	265+285+285	285+285+285	285+285+305	285+305+305	305+305+305	
65				66	68	69	70	
-5 ~ 49								
-20 ~ 15.5								
R410A								
9.1+9.3+9.3	9.3+9.3+9.3	9.3+9.3+11.8	9.3+11.8+11.8	11.8+11.8+11.8				
Ø 19.1								
Ø 41.3								

**Note: Specifications are based on the following conditions:**

- Cooling: Indoor temp.: 27°CDB, 19°CWB, Outdoor temp.: 35°CDB, Equivalent piping length: 7.5m, Level difference: 0.
- Heating: Indoor temp.: 20°CDB, Outdoor temp.: 7°CDB, 6°WB, Equivalent piping length: 7.5m, Level difference: 0m.
- Sound level: Anechoic chamber conversion value, measured at a point 1m in front of the unit at a height of 1.5m.  
During actual operation, these values are normally somewhat higher as a result of ambient conditions.



---

OUTDOOR UNIT  
COMBINATIONS  
& OPTIONS LIST

# OUTDOOR UNIT COMBINATIONS



## VRV X

HP	Capacity index	Model name	Combination for cooling only	Combination for heat pump	Outdoor unit multi connection piping kit *1	Total capacity index of connectable indoor units*2	Maximum number of connectable indoor units*2
6	150	RX(Y)Q6A	RXQ6A	RXYQ6A	—	75 to 195 (300)	9 (15)
8	200	RX(Y)Q8A	RXQ8A	RXYQ8A	—	100 to 260 (400)	13 (20)
10	250	RX(Y)Q10A	RXQ10A	RXYQ10A	—	125 to 325 (500)	16 (25)
12	300	RX(Y)Q12A	RXQ12A	RXYQ12A	—	150 to 390 (600)	19 (30)
14	350	RX(Y)Q14A	RXQ14A	RXYQ14A	—	175 to 455 (700)	22 (35)
16	400	RX(Y)Q16A	RXQ16A	RXYQ16A	—	200 to 520 (800)	26 (40)
18	450	RX(Y)Q18A	RXQ18A	RXYQ18A	—	225 to 585 (900)	29 (45)
20	500	RX(Y)Q20A	RXQ20A	RXYQ20A	—	250 to 650 (1,000)	32 (50)
22	550	RX(Y)Q22A	RXQ10A + RXQ12A	RXYQ10A + RXYQ12A	BHFFP22P1006	275 to 715 (880)	35 (44)
24	600	RX(Y)Q24A	RXQ12A x 2	RXYQ12A x 2		300 to 780 (960)	39 (48)
26	650	RX(Y)Q26A	RXQ12A + RXQ14A	RXYQ12A + RXYQ14A		325 to 845 (1,040)	42 (52)
28	700	RX(Y)Q28A	RXQ12A + RXQ16A	RXYQ12A + RXYQ16A		350 to 910 (1,120)	45 (56)
30	750	RX(Y)Q30A	RXQ12A + RXQ18A	RXYQ12A + RXYQ18A		375 to 975 (1,200)	48 (60)
32	800	RX(Y)Q32A	RXQ14A + RXQ18A	RXYQ16A + RXYQ18A		400 to 1,040 (1,280)	52 (64)
34	850	RX(Y)Q34A	RXQ16A + RXQ18A	RXYQ16A + RXYQ18A		425 to 1,105 (1,360)	55 (64)
36	900	RX(Y)Q36A	RXQ18A x 2	RXYQ16A + RXYQ20A		450 to 1,170 (1,440)	58 (64)
38	950	RX(Y)Q38A	RXQ18A + RXQ20A	RXYQ18A + RXYQ20A		475 to 1,235 (1,520)	61 (64)
40	1,000	RX(Y)Q40A	RXQ20A x 2	RXYQ20A x 2		500 to 1,300 (1,600)	64 (64)
42	1,050	RX(Y)Q42A	RXQ12A x 2 + RXQ18A	RXYQ12A x 2 + RXYQ18A		525 to 1,365 (1,665)	
44	1,100	RX(Y)Q44A	RXQ12A x 2 + RXQ20A	RXYQ12A x 2 + RXYQ20A		550 to 1,430 (1,740)	
46	1,150	RX(Y)Q46A	RXQ14A + RXQ14A + RXQ18A	RXYQ14A + RXYQ16A + RXYQ18A		575 to 1,495 (1,795)	
48	1,200	RX(Y)Q48A	RXQ14A + RXQ16A + RXQ18A	RXYQ16A x 3		600 to 1,560 (1,860)	
50	1,250	RX(Y)Q50A	RXQ14A + RXQ18A + RXQ18A	RXYQ16A + RXYQ16A + RXYQ18A	625 to 1,625 (1,925)		
52	1,300	RX(Y)Q52A	RXQ16A + RXQ18A x 2	RXYQ16A + RXYQ18A x 2	650 to 1,690 (1,990)		
54	1,350	RX(Y)Q54A	RXQ18A x 3	RXYQ18A x 3	675 to 1,755 (1,995)		
56	1,400	RX(Y)Q56A	RXQ18A x 2 + RXQ20A	RXYQ18A x 2 + RXYQ20A	700 to 1,820 (1,990)		
58	1,450	RX(Y)Q58A	RXQ18A + RXQ20A x 2	RXYQ18A + RXYQ20A x 2	725 to 1,885 (1,995)		
60	1,500	RX(Y)Q60A	RXQ20A x 3	RXYQ20A x 3	750 to 1,950 (1,995)		

**Note:** \*1 For multiple connection of 22 HP systems and above, the outdoor unit multi connection piping kit (separately sold) is required.

\*2 Values inside brackets are based on connection of indoor units rated at maximum capacity, 200% for single outdoor units, 160% for double outdoor units, and 130% for triple outdoor units. Refer to page 17 for notes on connection capacity of indoor units.

## VRV Indoor Units

### Ceiling Mounted Cassette Round Flow & Round Flow With Sensing (Optional)

No.	Item		Type	FXFSQ25A FXFSQ32A FXFSQ40A	FXFSQ50A FXFSQ63A FXFSQ80A	FXFSQ100A FXFSQ125A FXFSQ140A
1	Decoration panel	Standard panel	Fresh white	BYCQ125EAF6 *		
			Black	BYCQ125EAK *		
		Designer panel <sup>1</sup>	Fresh white	BYCQ125EAPF *		
		Auto grille panel <sup>2,3</sup>	Fresh white	BYCQ125EASF *		
		Sensing panel	Fresh white	BYCQ140EEF6 *		
Black	BYCQ125EEK *					
2	Sealing material of air discharge outlet <sup>4</sup>		For usage of 3-4-way flow	KDBH551C160		
			For usage of 2-way flow	KDBH552C160		
3	Panel spacer			KDBP55H160FA		
4	Fresh air intake kit		Chamber type <sup>5,6</sup>	Without T-duct joint	KDDP55B160 (Components: KDDP55C160-1, KDDP55B160-2) <sup>8</sup>	
				With T-duct joint	KDDP55B160K (Components: KDDP55C160-1, KDDP55B160K2) <sup>8</sup>	
			Direct installation type <sup>7</sup>	KDDP55X160A		
5	High-efficiency filter unit <sup>9</sup> (Including filter chamber)		(Colorimetric method 65%)	KAFP556C80	KAFP556C160	
			(Colorimetric method 90%)	KAFP557C80	KAFP557C160	
6	Replacement high-efficiency filter <sup>9,10</sup>		(Colorimetric method 65%)	KAFP552B80	KAFP552B160	
			(Colorimetric method 90%)	KAFP553B80	KAFP553B160	
7	Filter chamber			KDDFP55C160		
8	Replacement long-life filter			KAFP551K160		
9	Replacement long-life filter (Auto grille panel)			KAFP551H160		
10	Ultra long-life filter unit (Including filter chamber) <sup>9</sup>			KAFP55C160		
11	Replacement ultra long-life filter <sup>9,10</sup>			KAFP55H160H		
12	Branch duct chamber <sup>4</sup>			KDJP55C80	KDJP55C160	
13	Insulation kit for high humidity <sup>9,11</sup>			KDTP55K80	KDTP55K160	

**Note:**

- When installing designer panel, body height (ceiling required dimension) is 42 mm higher than standard panel. Designer panel cannot operate 2 and 3 way flow.
  - A dedicated wireless remote controller (BRC16A2) for the auto grille panel is included for lowering and raising the suction grille.
  - When installing auto grille panel, body height (ceiling required dimension) is 55 mm higher than standard panel.
  - Circulation airflow is not available with this option.
  - When installing a fresh air intake kit (chamber type), two air outlet corners are closed.
  - It is recommended that the volume of outdoor air introduced through the kit is limited to 10% of the maximum airflow rate of the indoor unit. Introducing higher quantities will increase the operating sound and may also influence temperature sensing.
  - The volume of fresh air for direct installation type is approximately 1% of the indoor unit airflow. The chamber type is recommended when more fresh air is necessary.
  - Please order using the names of both components instead of set name.
  - This option cannot be installed to designer panel and auto grille panel.
  - Filter chamber is required.
  - Please use in case temperature/humidity inside ceiling may get over 30°C, 80% RH.
- \*These panels do not contain the sensing function.

### Ceiling Mounted Cassette (Compact Multi Flow) Type

FOR UNIT	MODEL
Grid ceiling panel	BYFQ60CAW
Decoration panel	BYFQ60B3W1* <sup>1</sup>
Relay wire harness adaptor for decoration panel* <sup>1</sup>	BER01A1
Sensor kit for grid ceiling panel	BRYQ60AAW
Sealing material for air discharge outlet	BDBHQ44C60
Replacement long life filter	KAF441C60
Fresh air intake kit	KDDQ44XA60

**Notes:**

- Option relay wire harness adaptor (BER01A1) is necessary when installing decoration panel (BYFQ60B3W1).
- Installation box\*<sup>2</sup> is necessary for each adaptor marked \*.
- Up to 2 adaptors can be fixed for each installation box.
- Only one installation box can be installed for each indoor unit.

## Ceiling Mounted Cassette (Double Flow) Type

No.	Item	Type	FXCQ25A	FXCQ32A FXCQ40A	FXCQ50A	FXCQ63A	FXCQ80A	FXCQ125A
1	Decoration panel		BYBCQ40CF		BYBCQ63CF		BYBCQ125CF	
2	Filter related	High efficiency filter*1	65%	KAFP532B50	KAFP532B80	KAFP532B160		
			90%	KAFP533B50	KAFP533B80	KAFP533B160		
		Filter chamber bottom suction	KDDFP53B50		KDDFP53B80		KDDFP53B160	
	Long-life replacement filter	KAFP531B50		KAFP531B80		KAFP531B160		
3	Remote controller	Wireless	H/P		BRC7M65			
4	Navigation remote controller (Wired remote controller)		BRC1E63					

Note: \* 1 Filter chamber is required if installing high efficiency filter.

## Ceiling Mounted Cassette Corner Type

Item	MODEL			
	FXKQ32AV16	FXKQ40AV16	FXKQ50AV16	FXKQ63AV16
Decoration panel	BYKQ63AHW (Surface colour: White / Base colour: Dark gray)			
	BYKQ63AHS (Surface colour: Silver / Base colour: Dark gray)			
	BYKQ63AW (Surface Colour: White/ Base Colour: White)			
PM2.5 filter	Initial installation kit (Frame + PM 2.5 filter) Model: BAF25A6			
	Only PM 2.5 filter replacement Part No.: 3P454777-3			
Spacer Kit	BKF25A6 / BKF25CA6 / BKF50CA6 / BKF75SA6			

C: 4D138977A

## Slim Ceiling Mounted Duct Type (700 mm width type)

No.	Item	Type	FXDQ20PD	FXDQ25PD	FXDQ32PD
1	Insulation kit for high humidity			KDT25N32	

## Slim Ceiling Mounted Duct Type (900/1,100 mm width type)

No.	Item	Type	FXDQ40ND	FXDQ50ND	FXDQ63ND
1	Insulation kit for high humidity		KDT25N50		KDT25N63

## High Static Ceiling Mounted Duct Type

No.	Item	Type	FXMQ20P FXMQ25P FXMQ32P	FXMQ40PBV36	FXMQ50PBV36 FXMQ63PBV36 FXMQ80PBV36	FXMQ100PBV36 FXMQ125PBV36 FXMQ140PBV36
1	Drain pump kit		-			
2	High efficiency filter	65%	KAF372AA36	KAF372AA56	KAF372AA80	KAF372AA160
		90%	-	KAF373AA56	KAF373AA80	KAF373AA160
3	Filter chamber		-	BDDF37A40~6	BDDF37A80~6	BDDF37A140~6
4	Long-life replacement filter		-	KAF371AA56	KAF371AA80	KAF371AA160
5	Long-life filter chamber kit		-	KAF375AA56	KAF375AA80	KAF375AA160
6	Service panel	White	-	KTBJ25K56W	KTBJ25K80W	KTBJ25K160W
		Fresh white	KTBJ25K36F	KTBJ25K56F	KTBJ25K80F	KTBJ25K160F
		Brown	-	KTBJ25K56T	KTBJ25K80T	KTBJ25K160T
7	Air discharge adaptor		KDAJ25K36A	KDAJ25K56A	KDAJ25K71A	KDAJ25K140A
8	Suction flange		-	BDF37A40~6	BDF37A80~6	BDF37A140~6

## VRV Indoor Units

### Ceiling Suspended Type

No.	Item	Type	FXHQ32MA	FXHQ63MA	FXHQ100MA
1	Drain pump kit		KDU50N60VE	KDU50N125VE	
2	Replacement long-life filter (Resin net)		KAF501DA56	KAF501DA80	KAF501DA112
3	L-type piping kit (for upward direction)		KHFP5MA63	KHFP5MA160	

### Floor Standing Type/Concealed Floor Standing Type

No.	Item	Type	FXLQ32MA/FXNQ32MA	FXLQ50MA/FXNQ50MA	FXLQ63MA/FXNQ63MA
1	Long-life replacement filter		KAFJ361K45	KAFJ361K71	

### Mid Static Ceiling Mounted Duct Type

No.	Item	Type	Duct Type	
			FXMQ40ARV16, FXMQ50ARV16	FXMQ63ARV16, FXMQ80ARV16, FXMQ100ARV16
1	High efficiency filter	65% Type	KAF372AA56	KAF372AA80
2	Filter chamber	Type	BDDF37A40~6	BDDF37A80~6
3	Long-life replacement filter	Type	KAF371AA56	KAF371AA80
4	Suction flange		BDF37A40~6	BDF37A80~6
			KTBJ25K56W	KTBJ25K80W
5	Service panel		KTBJ25K56F	KTBJ25K80F
			KTBJ25K56T	KTBJ25K80T
6	Air discharge adaptor		KDAJ25K56A	KDAJ25K71A

### Floor Standing Duct Type

No.	Item	Type	FXVQ125N	FXVQ200N	FXVQ250N	FXVQ400N	FXVQ500N	
1	Replacement long life filter		KAFJ261M140	KAFJ261M224	KAFJ261M280	KAFJ261N450	KAFJ261N560	
2	Ultra long-life filter			—		KAFSJ9A400	KAFSJ9A560	
3	Discharge and Suction Front suction filter chamber for high efficiency filter	Filter chamber for high efficiency filter *1	65% KDDF-92A140	KDDF-92A200	KDDF-92A280	KDDF-92A400	KDDF-92A560	
4		90% KDDF-93A140	KDDF-93A200	KDDF-93A280	KDDF-93A400	KDDF-93A560		
5		Front suction base flange	KD-9A140	KD-9A200	KD-9A280	KD-9A400	KD-9A560	
6		Suction grille	KDGF-9A140	KDGF-9A200	KDGF-9A280	KDGF-9A400	KDGF-9A560	
7		Replacement filter *2	Long-life filter *3	KAF-91B140	KAF-91B200	KAF-91B280	KAF-91B400	KAF-91B560
8			High efficiency filter	65% KAF-92B140	KAF-92B200	KAF-92B280	KAF-92B400	KAF-92B560
9			90% KAF-93B140	KAF-93B200	KAF-93B280	KAF-93B400	KAF-93B560	
10		Plenum chamber *4		KPCJ140A	KPC5J	KPC8J	KPCJ400A	KPC15JA
11		Pulley for plenum chamber *4		KPP8JA	KPP9JA	KPP10JA	—	
12		Fresh air intake kit		KD106D10			KDFJ906A560	
13	Rear suction kit		KDFJ905A140	KDFJ905A200	KDFJ905A280	KDFJ905A400	KDFJ905A560	
14	Discharge grille for plenum side		KD101A10			KD101A20		
15	Wood base		KKWJ9A140	KWF1G5P	KWF1G8P	KKWJ9A400	KWF1G15	
16	Vibration isolating frame		K-ABSG1406A	K-ABSG1407A	K-ABSG1408A	K-ABSG1409A	K-ABSG1410A	

\*1 A front suction base flange and suction grille are required (option).

\*3 Different from the filter attached as standard.

\*2 A filter chamber for high efficiency is required (option).

\*4 Use the plenum chamber and pulley for plenum chamber in combination.

### Clean Room Air Conditioner

No.	Item	Type	FXBQ40PVE	FXBQ50PVE	FXBQ63PVE	FXBQ63PVE
1	Outlet unit		—			BAF82A63
2	Filter	HEPA filter	BAFH82A50		BAFH82A63	
3	Panel	Ceiling intake type	BYB82A50C		BYB82A63C	BYB82A63CP
4		Floor-level intake type	BYB82A50W		BYB82A63W	BYB82A63WP
5	Outside air intake duct flange		KDFJ82A80			

## VRV X

Optional Accessories		RX(Y)Q6ARY6 RX(Y)Q8ARY6 RX(Y)Q10ARY6	RX(Y)Q12ARY6	RX(Y)Q14ARY6 RX(Y)Q16ARY6
Distributive piping	REFNET header	KHRP26M22H, (Max. 4 branch) KHRP26M33H (Max. 8 branch)	KHRP26M22H, KHRP26M33H, KHRP26M72H (Max. 4 branch) (Max. 8 branch) (Max. 8 branch)	
	REFNET joint	KHRP26A22T KHRP26A33T	KHRP26A22T, KHRP26A33T, KHRP26A72T	

Optional Accessories		RX(Y)Q18ARY6 RX(Y)Q20ARY6
Distributive piping	REFNET header	KHRP26M22H, KHRP26M33H, KHRP26M72H (Max. 4 branch) (Max. 8 branch) (Max. 8 branch)
	REFNET joint	KHRP26A22T, KHRP26A33T, KHRP26A72T

Optional Accessories		RX(Y)Q22ARY6	RX(Y)Q24ARY6	RX(Y)Q26ARY6 RX(Y)Q28ARY6 RX(Y)Q30ARY6 RX(Y)Q32ARY6	RX(Y)Q34ARY6 RX(Y)Q36ARY6 RX(Y)Q38ARY6 RX(Y)Q40ARY6
Distributive piping	REFNET header	KHRP26M22H (Max. 4 branch), KHRP26M33H (Max. 8 branch), KHRP26M72H (Max. 8 branch),	KHRP26M22H, KHRP26M33H, KHRP26M72H, KHRP26M73H (Max. 4 branch) (Max. 8 branch) (Max. 8 branch) (Max. 8 branch)		
	REFNET joint	KHRP26A22T, KHRP26M33T, KHRP26M72T,	KHRP26A22T, KHRP26A33T, KHRP26A72T, KHRP26A73T		
Pipe size reducer		—		KHRP26M73TP, KHRP26M73HP	
Outdoor unit connection piping kit		BHFP22P1006			

Optional Accessories		RX(Y)Q42ARY6 RX(Y)Q44ARY6	RX(Y)Q46ARY6 RX(Y)Q48ARY6 RX(Y)Q50ARY6 RX(Y)Q52ARY6 RX(Y)Q54ARY6 RX(Y)Q56ARY6 RX(Y)Q58ARY6 RX(Y)Q60ARY6
Distributive piping	REFNET header	KHRP26M22H, KHRP26M33H, KHRP26M72H, KHRP26M73H (Max. 4 branch) (Max. 8 branch) (Max. 8 branch) (Max. 8 branch)	
	REFNET joint	KHRP26A22T, KHRP26A33T, KHRP26A72T, KHRP26A73T	
Pipe size reducer		KHRP26M73TP, KHRP26M73HP	
Outdoor unit connection piping kit		BHFP22P1516	



**VRV X**

**CONTROL  
SYSTEMS**

# Reiri OFFICE | HOME | HOTEL

## Reiri for Office

Reiri for Office is the ideal building management solution for all sizes of commercial buildings, especially for small to medium-sized buildings, regardless of location. This smart building solution provides affordable and scalable building control and energy management, allowing users greater control and automation of building utilities such as air-conditioning and lighting, and to monitor and manage energy performance and indoor air quality.



Expanded Features



Reiri for Office  
DCPF01



Reiri for Office  
Controller Extension  
DCPF05



Reiri for Office  
Multisite Extension  
DCPF10

## Reiri for Home



Reiri for Home is the complete smart home solution with seamless integration capabilities, allowing users to control and monitor all smart home devices conveniently from just a single mobile app. From security and safety enhancements to indoor air quality and energy management, Reiri for Home is the ideal home automation system for every homeowner.



Reiri for Home  
DCPH01



Reiri for Home  
Lite Version  
DCPH02

## Reiri for Hotel

Reiri for Hotel effectively saves energy and cost while prioritizing guests' comfort and satisfaction. With this smart hotel solution, energy consumption is optimised without compromising on the guests' in-room comfort. Hotel managers and staff are also able to conveniently monitor the status and manage the settings of every room.



Reiri for Hotel  
DCPL01



Reiri for Resort  
DCPRO1



### CONNECTABLE

Various types of equipment in a building can be controlled by a single controller.

**Individual Air-conditioning Control**  
From VRV to SkyAir to Split Units, conveniently manage all air-conditioning needs with flexible and precise control when connected to Reiri.

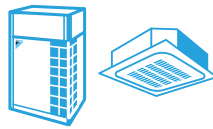

**Lighting Control** **DALI Compatible**  
Monitor and control DALI-compatible LED lighting systems from a single controller with enhanced automation through interlocking functions with air-conditioners and other connectable devices.

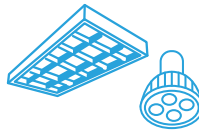

**Smart Devices**  
Connect to a wide variety of smart devices, ranging from IP cameras to locks and sensors, and access all of them from just one Reiri app.

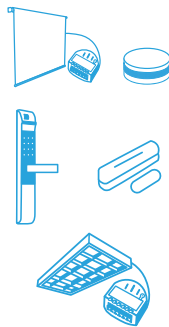



## BENEFITS OF REIRI

### Energy Saving

By automating air-conditioning and lighting controls through available functions such as scheduling and interlocking, energy consumption is greatly minimized while maximising comfort and efficiency.

### Energy and Cost Management

Easily monitor and analyse energy consumption with data trend graphs, reports and even real-time energy monitoring display. Tenant billing management is also available for effective cost management.

### Integration Capabilities

Reiri is able to integrate and connect to various sensors and smart devices, thus making it the ideal all-in-one platform to monitor and control every room's indoor environment, such as temperature, humidity, indoor air quality and illuminance.

Energy-efficient control of air-conditioning and lighting is the key to cutting energy costs.

Electricity consumption ratio in typical office buildings.

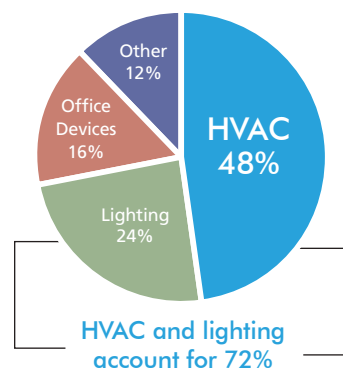

Source: Agency for Natural Resources and Energy, Government of Japan



For More information  
'Scan Me'



For More information  
'Scan Me'

## Individual Control Systems for VRV Indoor Units

### Navigation remote controller (Wired remote controller) (Optional)



**BRC1E63 & BRC1F61 (Only for FXEQ Series)**

#### Clear display

- **Dot matrix display**

A combination of fine dots enables various icons. Large text display is easy to see.

- **Backlight display**

Backlight display helps operating in dark rooms.

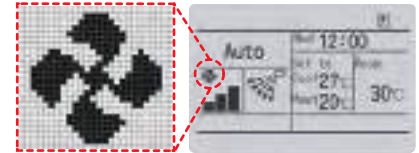

#### Simple operation

- **Large buttons and arrow keys**

Large buttons and arrow keys enable easy operation. Basic setting such as fan speed and temperature can be intuitively operated. For other settings, just select the function from the menu list.



- **Guide on display**

The display gives an explanation of each setting for easy operation.

### Energy saving

- **Set point range set**

- Saves energy by limiting the min. and max. set temperature.
- Avoids excessive cooling or heating.
- This function is convenient when the remote controller is installed at a place where any number of people may operate it.

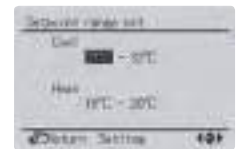

- **Set point auto-reset**

- Even if the set temperature is changed, it returns to the preset temperature after a preset period of time.
- Period selectable from 30 min/60 min/90 min/120 min.



- **Off timer**

- Turns off the air conditioner after a preset period of time.
- Period can be preset from 30 to 180 minutes in 10-minute increments.

#### Restaurant sample

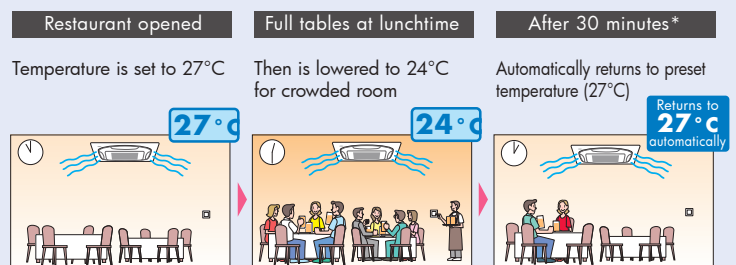

\*Setting possible for after 30, 60, 90, and 120 minutes.

## Convenience

### ● Setback (default: OFF)

Maintains the room temperature in a specific range during an unoccupied period by temporarily starting air conditioner that was turned OFF.

Ex) Setback temperature **Cooling : 35°C** Recovery differential **Cooling : -2°C**  
 When the room temperature goes above 35°C, the air conditioner starts operating in Cooling automatically.  
 When room temperature reaches 33°C, the air conditioner turns OFF.

	Setback temperature	Recovery differential
<b>Cooling</b>	<b>33 — 37 °C</b>	<b>-2 — -8 °C</b>

### ● Weekly schedule

- Five actions per day can be scheduled for each day of the week.
- The holiday function will disable schedule timer for the days that have been set as holiday.
- Three independent schedules can be set (e.g. summer, winter, mid-season).

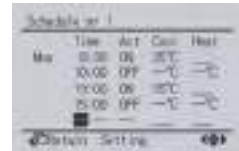

### College classroom sample (a summer Monday case)

1) 8:30 ON

The first period starts and the air conditioner starts the cooling operation.

ON

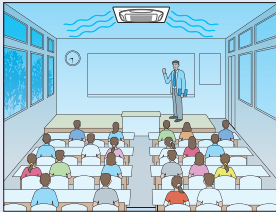

2) 10:00 OFF

In the second period, the classroom is unoccupied and the air conditioner stops.

OFF

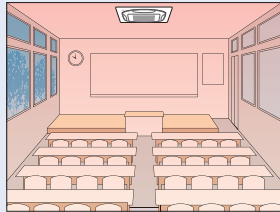

3) 13:00 ON

When the third period starts, the air conditioner operation starts again.

ON

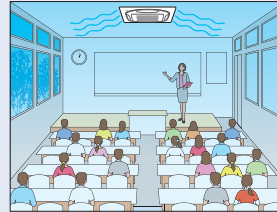

4) 15:00 OFF

After the third period, the classroom becomes vacant again and the air conditioner stops.

OFF

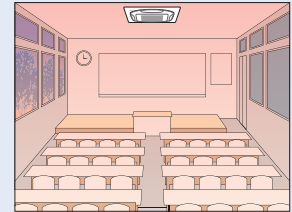

## Comfort

### ● Individual airflow direction (\*1)

Airflow direction of each of the four air outlets can be controlled individually. (Positions 0 to 4, Swing, and No individual settings are selectable).

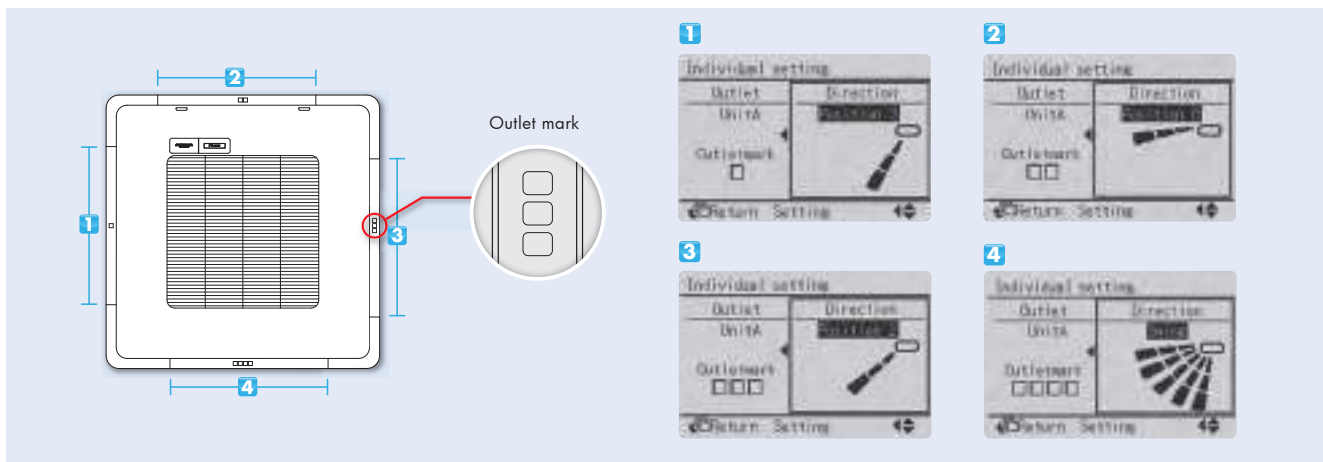

### ● Auto airflow rate (\*2)

Airflow rate is automatically controlled in accordance with the difference between room temperature and set temperature.

\*1 Only available for VRV 4-Way Flow Ceiling Suspended type FXUQ-A series.  
 \*2 Only available for VRV 4-Way Flow Ceiling Suspended type FXUQ-A series.

## Individual Control Systems for VRV Systems

### Stylish remote controller (Option) - Madoka



BRC1H61W (White)



BRC1H61K (Black)

A complete redesigned controller focused to enhance user experience



For More information  
'Scan Me'

### Product Features

- Combines refinement and simplicity.
- Echoes the distinct blue circle and simplicity of design.
- Two attractive colours to match any interior.
- Compact, measures only 85 x 85 mm.



### User-friendly interface

- Just three buttons and a large-figure display.
- Customisable display.
- Direct access to basic functions (ON/OFF, Operation mode, temperature setting, Airflow rate, Airflow direction).



### Easy setting via Bluetooth App with smartphone (for Installer/Facility Manager)

#### Keep hotel room comfortable

- Improved setback function by setting the lower temperature limit in cooling mode.

#### Shorter installation time

- Easy to create multiple remote control and field settings via App.
- Prepare a setting in advance at the office and immediately send it to the on-site remote controller.
- Save and reuse settings.



<App screen image>

## Stylish remote controller (Option)

### Easy operation with new intuitive design

#### Simple operation

Using only six buttons, users have direct access to basic functions. This enables them to easily set comfort to their preference.

- ON/OFF
- Operation mode
- Temperature setting
- Airflow rate (5-step & Auto)\*
- Up and down airflow direction (5-step & Swing)\*
- ON/OFF timer



BRC2E61

#### Intuitive design

- By using pictograms, the user- friendly interface enables convenient and easy operation.

#### Compact size

- Measuring only 85 x 85 mm, the new remote controller is extremely compact and complements any interior design.

## Wireless remote controller (Option)



Signal receiver unit  
(Installed type)

- The same operation mode and setting as with wired remote controllers are possible.  
\*Individual airflow direction, auto air-flow rate and sensor control can be set only via wired remote controller BRC1E62. They cannot be set via other remote controllers.
- A compact signal receiver unit (separate type) to be mounted into wall or ceiling is included.
- A signal receiver unit (installed type) for a Ceiling Mounted Cassette (Round Flow, Compact Multi Flow, Double Flow) type, Ceiling Suspended Type and Wall Mounted type is mounted into the Indoor unit.



Signal receiver unit can be installed on the panel.  
Ex. Ceiling Mounted Cassette (Round Flow) type

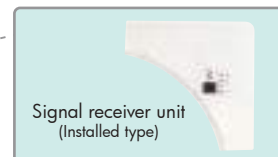

Signal receiver unit  
(Installed type)

\*Wireless remote controller and signal receiver unit are sold as a set.  
\*Refer to page 90 for the name of each model.

## Wide variation of remote controller for VRV indoor unit

	FXFQ-AVM FXFQ-S	FXZQ	FXCQ	FXUQ	FXEQ	FXDQ	FXMQ	FXHQ	FXAQ	FXL(N)Q	FXVQ
<b>Navigation remote controller</b> (Wired remote controller) BRC1E63	●	●	●	●	●	●	●	●	●	●	
<b>Wired remote controller</b> (BRC2E61)		●	●	●	●	●	●	●	●	●	
<b>Wireless remote controller*</b>	●	●	●	●	●	●	●	●	●	●	

## Centralised Control Systems for VRV Indoor Units

- Up to 64 groups of indoor units (128 units) can be centrally controlled.
- Optional controllers for centralised control can be combined freely, and system can be designed in accordance with building scale and purpose.
- System integrated with various air conditioning peripheral equipment such as Heat Reclaim Ventilator is easy.
- Wiring can be run up to a length of 2km, and adapts easily to large-scale system expansion.

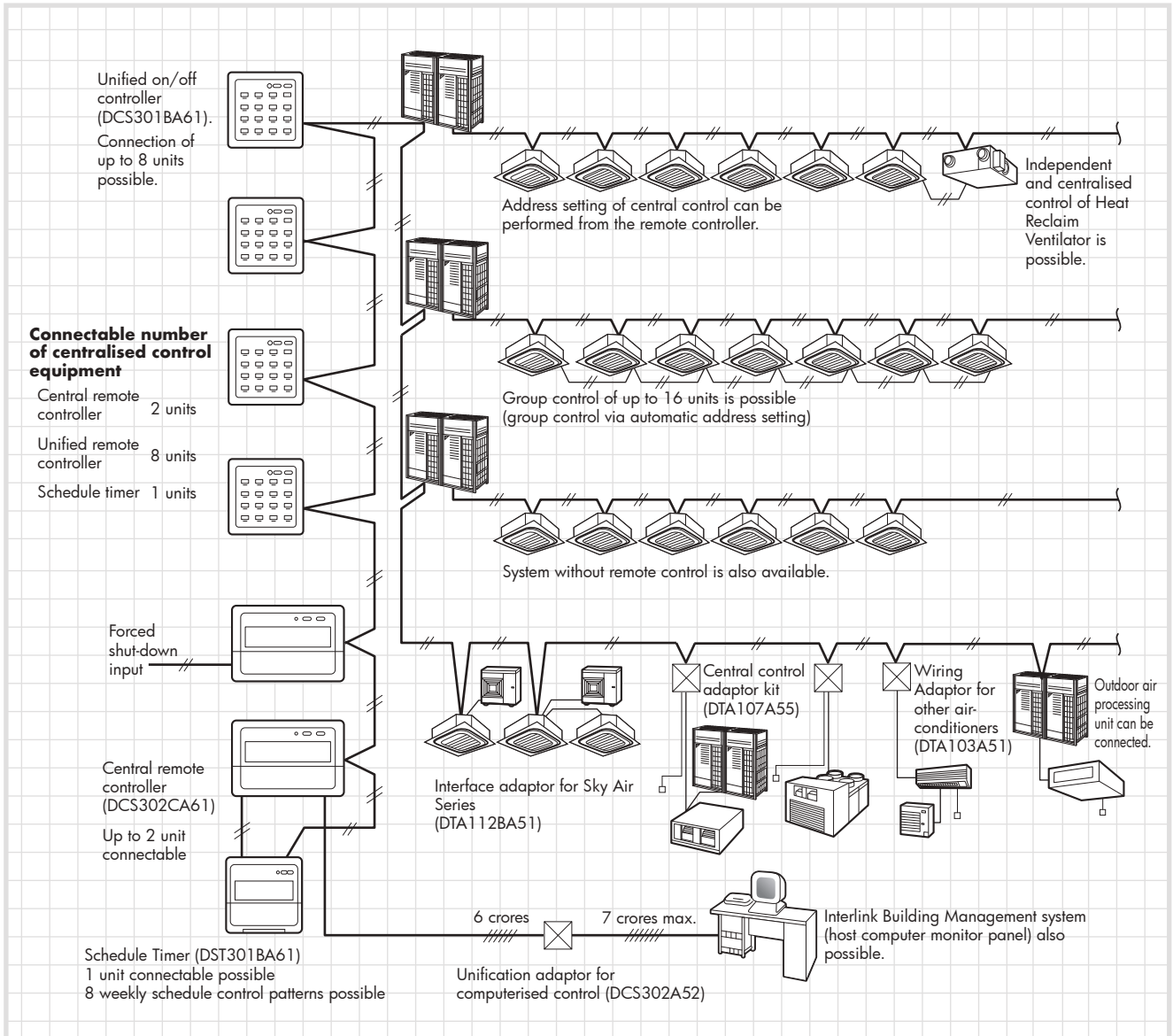

• Certain indoor units limit the functions of some control systems.

## Residential remote controller (Optional)



DCS303A51

**Max. 16 groups of indoor units can be easily controlled with the large LCD Panel.**

- Max. 16 group (128 indoor units) are controllable.
- Backlight and large LCD panel for easy readability.
- ON/OFF, temperature setting and scheduling can be controlled individually for indoor units.
- All indoor units can be turned on or off at once with "ALL" button.
- Outside temperature display.

\*For residential use only. Cannot be used with other centralised control equipment.

## Central remote controller (Optional)



DCS302CA61

**Max. 64 groups (zones) of indoor units can be controlled individually same as LCD remote controller.**

- Max. 64 group (128 indoor units) are controllable.
- Max. 128 group (128 indoor units) are controllable by using 2 central remote controllers, which can be controlled from 2 different places.
- Zone control.
- Malfunction code display.
- Max. wiring length of 1,000m (Total: 2,000m).
- Airflow volume and direction can be controlled individually for indoor units in each group operation.
- Ventilation volume and mode can be controlled for Heat Reclaim Ventilator.
- Up to 4 ON/OFF pairs can be set per day by connecting a schedule timer.

## Unified ON/OFF controller (Optional)



DCS301BA61

**Max. 16 groups of indoor units can be operated simultaneously/individually.**

- Max. 16 group (128 indoor units) are controllable.
- 2 remote controllers can be used to control 2 different places.
- Operating status indication (Normal Operation, Alarm).
- Centralised control indication.
- Max. wiring length of 1,000m (Total: 2,000m).
- Compact size casing (Thickness: 16mm).

## Schedule timer (Optional)



DST301BA61

**Max. 128 indoor units can be operated as programmed schedule.**

- Max. 128 indoor units are controllable.
- When used in combination with a central remote controller, a maximum of 8 weekly schedule patterns can be set, while the central controller can be used to select desired zones. Up to 2 ON/OFF pairs can be set per day.
- Max. 8 hours back-up power supply.
- Max. wiring length of 1,000m (Total: 2,000m).
- Compact size casing (Thickness: 16mm).

## Advanced Control Systems for VRV Indoor Units



**One touch selection enables flexible control of equipment in a building.**



For More information  
'Scan Me'



DCM601A51

Various types of equipment in a building can be controlled by a single controller.

### Individual air-conditioning control

The flexible control achieved by the VRV system precisely meets different air conditioning needs in each room (e.g. offices, conference rooms, hotel rooms).



### Lighting control

**DALI-compatible**

DALI-compatible LED lighting systems can be controlled and monitored. Lighting control is enhanced through an interlock function with air conditioners and other functions.

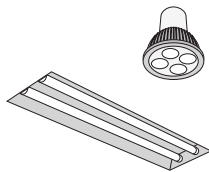

### Air conditioning control for large spaces

Air handling units can also be controlled. Large spaces, such as entrance halls and shopping malls, can be easily controlled to ensure comfort.

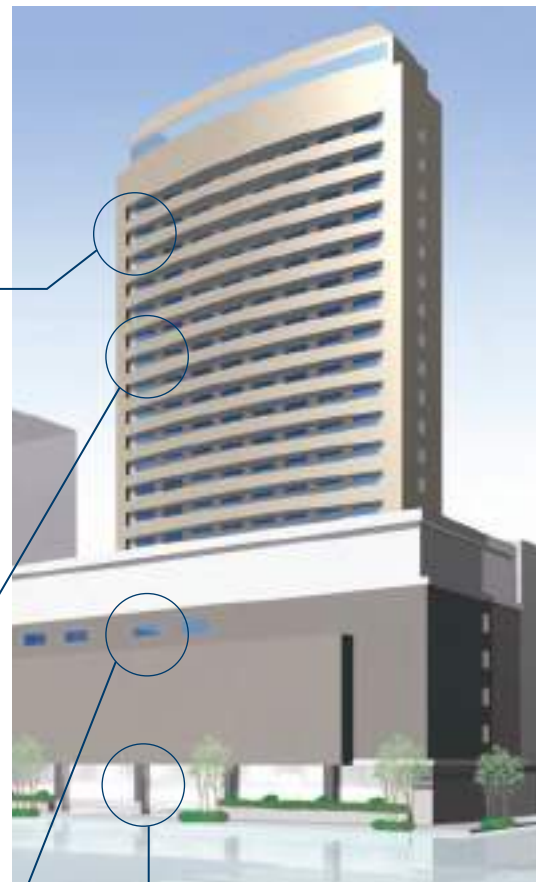

### Building equipment control

Various types of equipment other than air conditioners, including ventilators, fans, and pumps, can also be controlled.

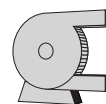

Pump



Fan

## For Energy Saving & Comfort

### Intelligent Touch Manager maximises the advantages of VRV features

Intelligent Touch Manager is an advanced multi-zone controller that provides the most cost-effective way to control and monitor the Daikin VRV system.

The 10.4" LCD touch screen is easy to use with three different screen views to include the floor plan layout view, icon view and list view and menus for system configurations.

It is also easy to use with standardised remote Web Access from your PC.

It can manage a total of 650 management points consisting of up to 512 Daikin indoor unit groups (up to 1024 indoor units) along with building equipment control / monitoring with Digital Inputs / Output (Di/Dio), Analog Inputs / Output (Ai/Ao) and Pulse input (Pi) optional devices.

#### Schedule the operation time for each application.

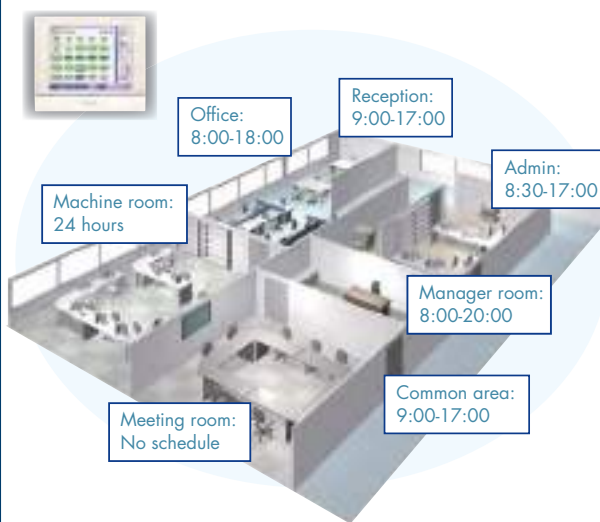

#### Define the set point range that users can change.

With Remote controller



With Control System

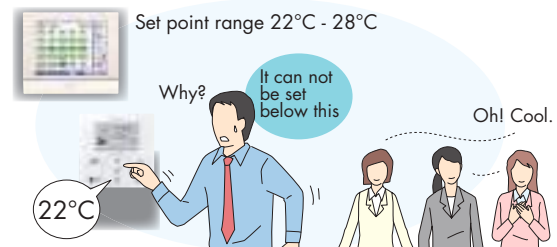

#### Turn the unit OFF, if a user didn't.

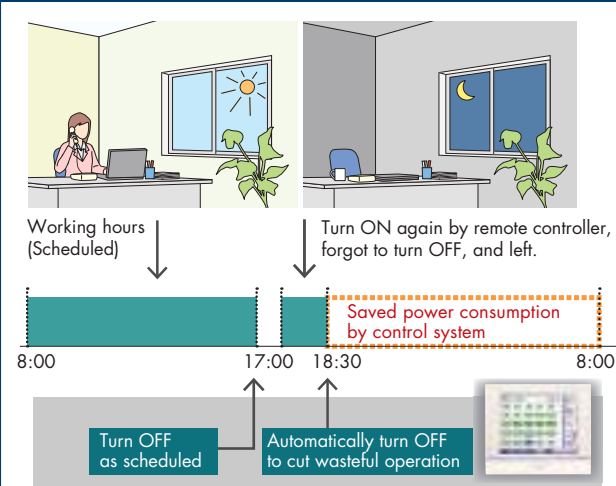

#### Reset set point regularly.

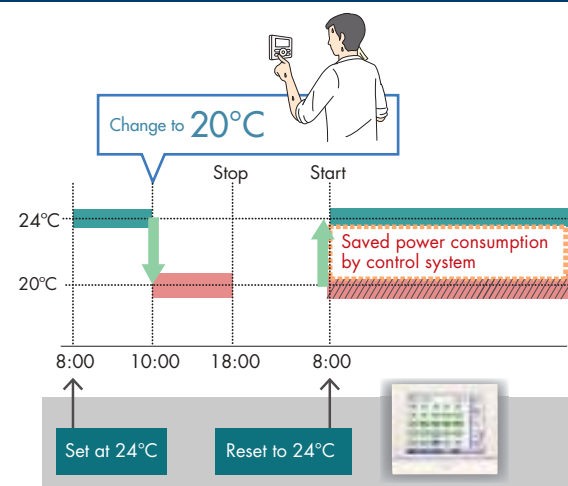

## Advanced Control Systems for VRV Indoor Units

In addition to switching lights on and off, advanced lighting control, such as illuminance adjustment, can be achieved.

### Lighting control (Optional)

Connection to DALI - compatible lighting control system

Simple wiring (daisy chain) enables management of LED lighting by the *Intelligent Touch Manager*.

Various air conditioning and lighting control is enabled through the interlock with occupancy sensors and illuminance sensors.

**DALI-compatible**

Please contact your local sales office for details.

Lighting control achieved by the *Intelligent Touch Manager*.

[Operation]

- Switch-on/switch-off operation.
- Illuminance (1–100%) control.
- Various illuminance patterns can be registered.
- Registered pattern can be selected from *Intelligent Touch Manager*.

[Monitoring]

- Switch-on/switch-off status monitoring.
- Lighting abnormality monitoring.
- Illuminance monitoring.
- DALI occupancy sensor monitoring.
- DALI illuminance sensor monitoring.

Air conditioning and lighting for which power consumption is high can be efficiently controlled to promote energy conservation and cost reduction!

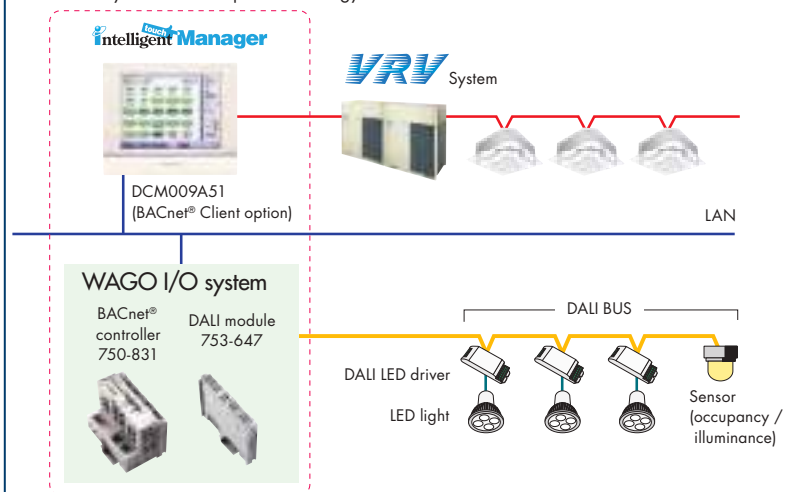

[Overview of control]

- Up to 5 DALI modules can be connected to a single BACnet® controller.
- Up to 64 DALI LED drivers (64 addresses) can be connected to a single DALI module.
- 64 DALI addresses can be freely assigned to up to 16 groups using a single DALI module.

(Each group corresponds to a management point of the *Intelligent Touch Manager*.)

- Up to 16 scenes can be set to a single DALI module.
- Up to 12 sensors (occupancy, illuminance) can be connected to a single DALI module.

- DALI BAS simplifies wiring and setting work by daisy chain wiring and automatic address setting.

## Easy maintenance and energy saving by lighting control.

### Case 1

Switch-on / switch-off and illuminance are controlled based on a schedule to cut wasteful power consumption.

- Failing to switch off lights is prevented.

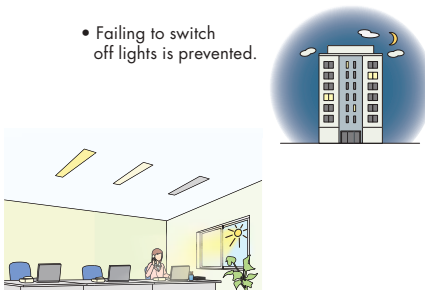

- Optimal illuminance reduces energy.

### Case 2

Occupancy sensors are used to eliminate both wasteful lighting and air conditioning.

When a room is unoccupied, the air conditioning stops and the lighting is switched off.

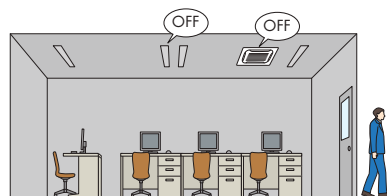

### Case 3

Lighting abnormalities (e.g. burned-out bulbs) can be checked on the *Intelligent Touch Manager* screen.

Lighting maintenance becomes easier and quicker.

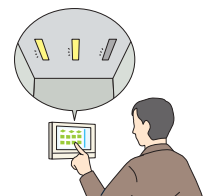

The layout screen enables quick identification of specific locations.

## Tenant Management (PPD Option)

### Reporting the power consumption of VRV system for each tenant.

#### With the PPD function, power consumption can be calculated for each indoor unit (Optional)

The energy consumption is proportionally calculated for each indoor unit. The data can be used for energy management and calculation of air conditioning usage fees for respective tenants.

Operational information of individual indoor units are monitored, based on distribution of power consumption of outdoor units.

Daikin's PPD keeps track of power distribution for each indoor unit. It performs air conditioning billing calculations quickly and automatically.

**It is easy to output PPD data.**

PPD data is output in CSV format to a PC or USB memory device and can be freely processed and managed.

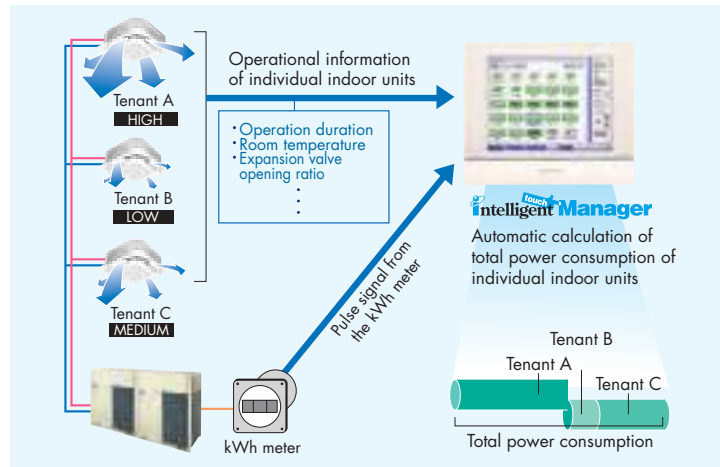

\*PPD (Power Proportional Distribution) is Daikin's proprietary calculation method.

### Air conditioning bills can be issued by one click.

#### Electricity bills can be easily calculated for each tenant (Optional)

The power consumption of VRV controlled by the Intelligent Touch Manager can be easily managed for each tenant using a PC. The electricity bill settings facilitate billing work through easy calculation and issuance of VRV electricity bills.

**[ Main functions ]**

- Register tenants.
- Set the electricity unit price for 5 time zones.
- Calculate power consumption and electricity charge for each tenant.
- Show aggregation results in the specified period for each tenant.
- Output the results (Printout and CSV file).

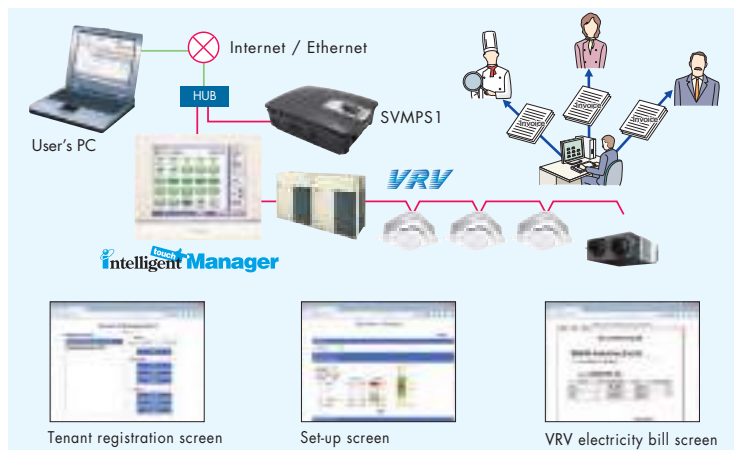

## Advanced Control Systems for VRV Indoor Units

### System Structure

#### Intelligent Touch Manager System Overview

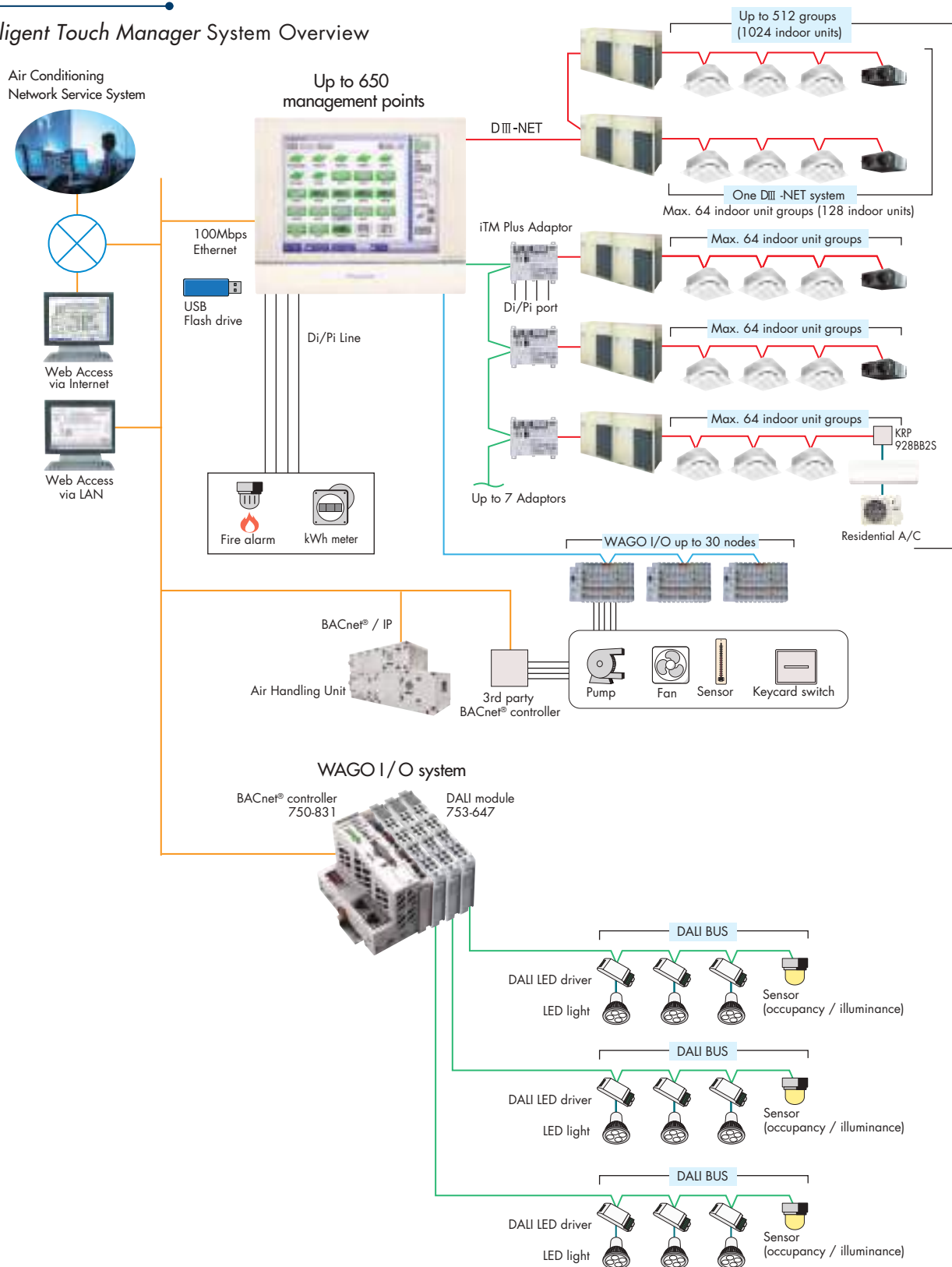

# Air Conditioning Network Service System

## Preventive Maintenance

The *Intelligent Touch Manager* can be connected to Daikin's own Air Conditioning Network Service System for remote monitoring and verification of operation status for VRV system. By its ability to predict malfunctions, this service provides customers with additional peace of mind.

## Enhanced convenience with link to the Air Conditioning Network Service System

The *Intelligent Touch Manager* connects seamlessly to Daikin's 24-hour Air Conditioning Network Service System.

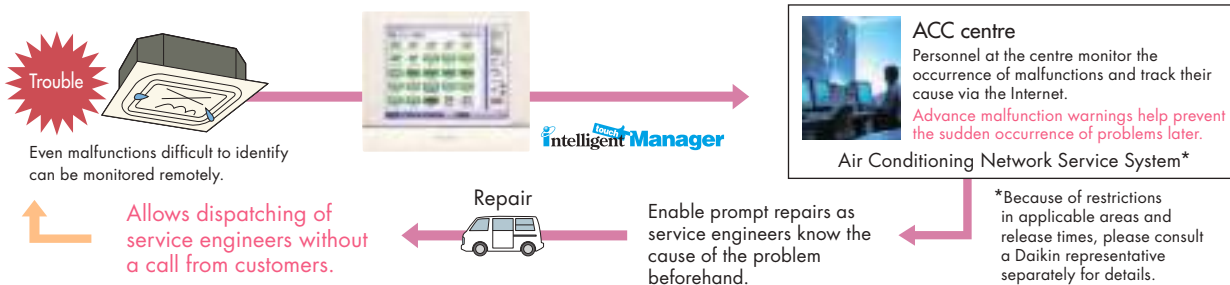

## Daikin Offers a Variety of Control Systems

### Convenient controllers that offer more freedom to administrators



DCS601C51

### Intelligent Controller

Ease of use and expanded control functions

The user-friendly controller features colours, multilingual function, and icons in the display for ease of understanding. A wide variety of control methods can be accommodated, permitting administrators to monitor and operate the system even when they are away from the controller.

### Connect VRV system to your BMS via BACnet® or LONWORKS®

Compatible with BACnet® and LONWORKS®, the two leading open network communication protocols, Daikin offers interfaces that provide a seamless connection between VRV system and your BMS.

Dedicated interfaces make Daikin air conditioners freely compatible with open networks



DMS502B51  
(Interface for use in BACnet®)

**BACnet®**  
Seamless connection between VRV system and BACnet® open network protocol.



DMS504B51  
(Interface for use in LONWORKS®)

**LONWORKS®**  
Facilitating the network integration of VRV system and LONWORKS®

Notes: 1. BACnet® is a registered trademark of American Society of Heating, Refrigerating and Air-Conditioning Engineers (ASHRAE).  
2. LONWORKS® is a trademark of Echelon Corporation registered in the United States and other countries.

## Modbus Interface Adaptor

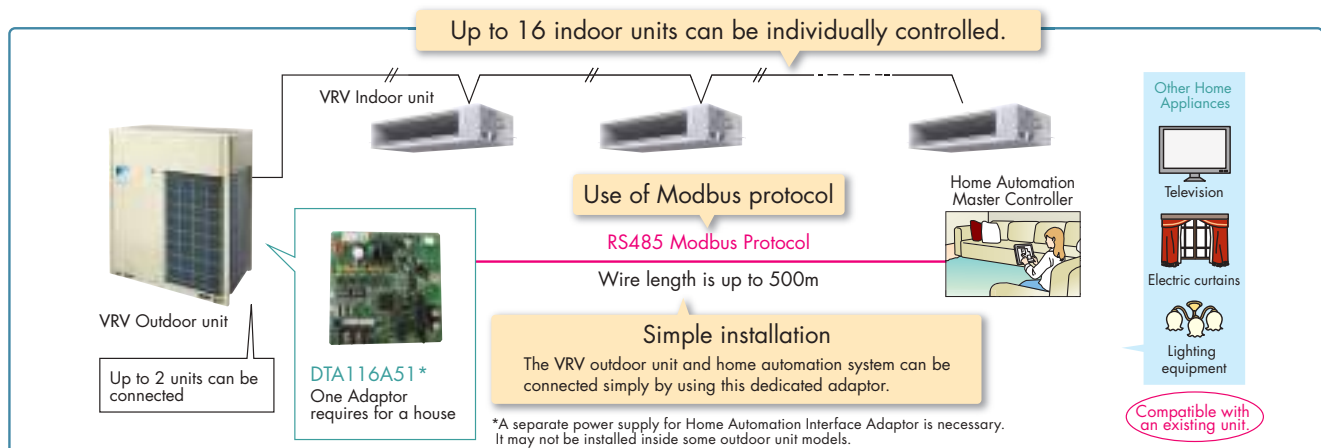

## Integrated Building Monitoring System

The high speed transmission of DIII-NET enables more advanced control of the VRV system, providing you with enhanced comfort.

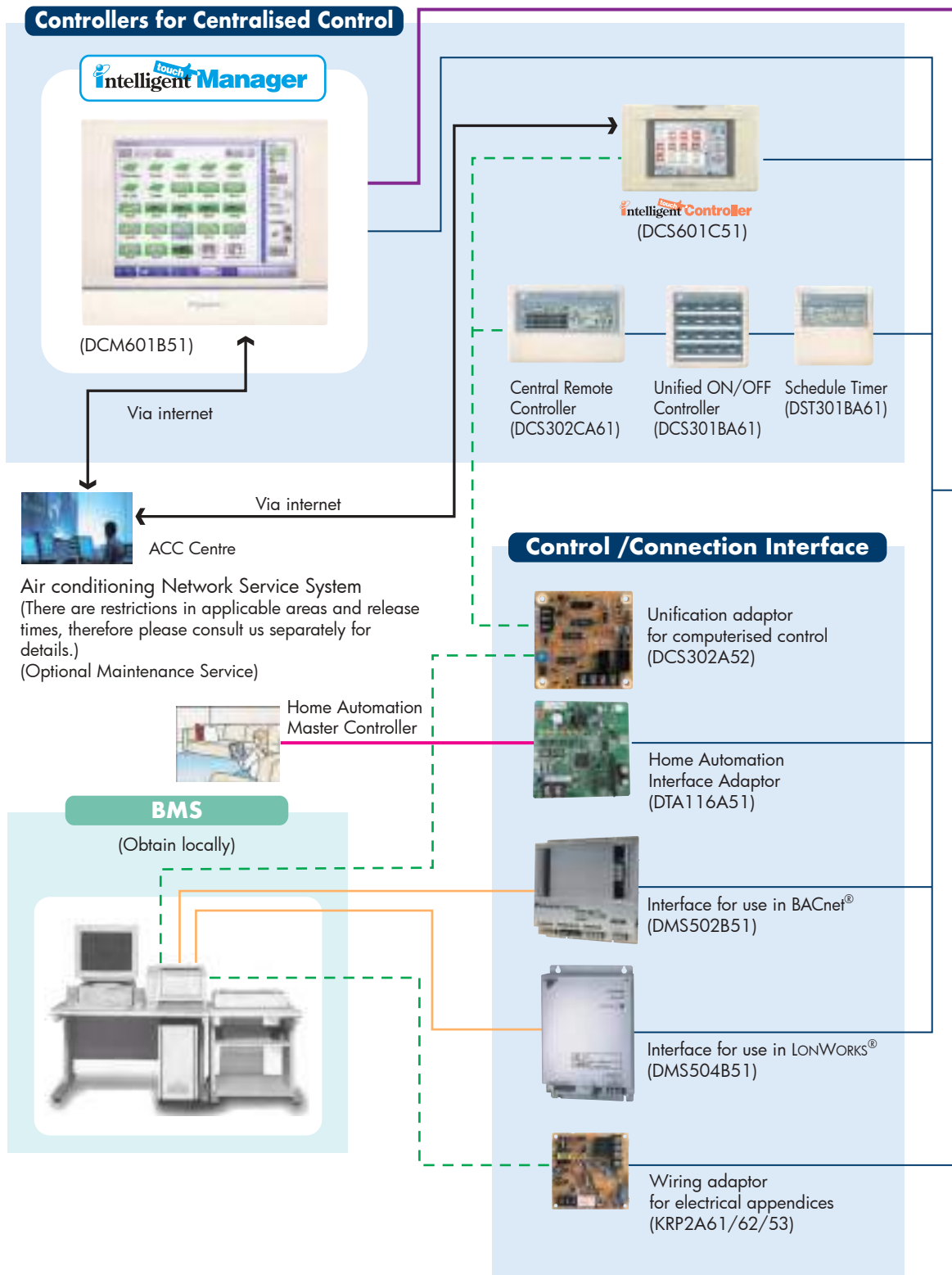

# Integrated Building Monitoring System

- DIII-NET Line
- BACnet®/Ethernet or LONWORKS® Network Communication Line
- - - Contact Signal Line
- RS485 Modbus Line
- WAGO Connection

The DIII-NET system provides for:

- Close control and monitoring by integrating a wide variety of air conditioners in the entire building.
- Saving the in-building cabling using non-polar, two-wire cables. Easier wiring work with tremendously fewer wiring errors.
- Additional set-ups readily up and running. An extendable cabling up to 2 km in total.
- Different control equipment flexibly joined in the system for hierarchical risk diversification.
- Daikin's total heat exchangers and other devices all under integral control.

## DIII-NET

(High Speed Multiple Transmission)

Our unique high speed multiple transmission system links air conditioners and various other building equipment in accordance with applications, scale and conditions and transmits vast amounts of information between them.

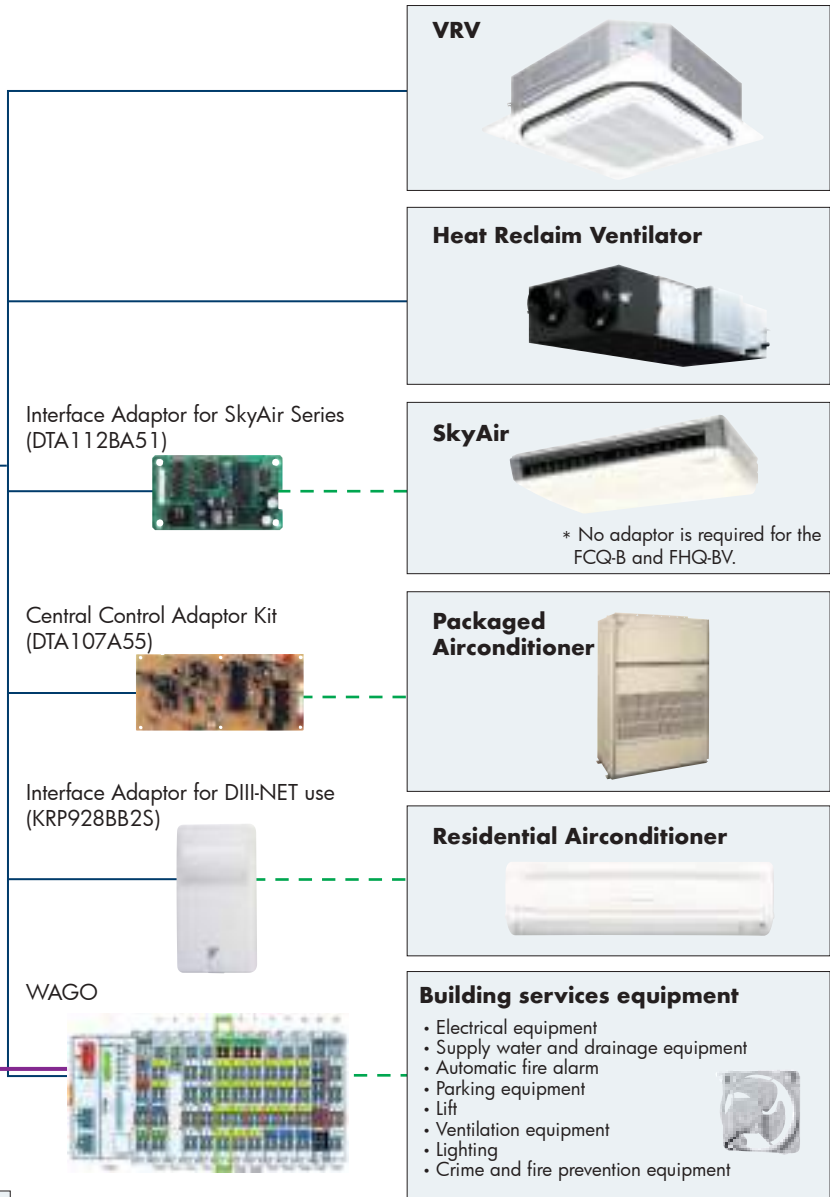

**Caution:**  
Limitation may apply to some models and functions. Please contact your local sales office for details. Consultation is necessary before employing this control system. Please contact your local sales office before making a purchase.

**Note:** BACnet® is a registered trademark of American Society of Heating, Refrigerating and Air-Conditioning Engineers (ASHRAE). LONWORKS® is a trademark of Echelon Corporation registered in the United States and other countries.

## Option List

### Operation Control System Optional Accessories

#### For VRV indoor unit use

No.	Item	Type		FXFSQ-A (For Black Panel)	FXFSQ-A	FXZQ-M	FXUQ-A	FXCQ-M	FXKQ-AV	FXDQ-PD FXDQ-ND
		Wireless	Receiver Handset							
1	Remote controller	Wireless	Receiver Handset	BRC7M634K	BRC7M632F-6	BRC7M630W-6	BRC7CB58	BRC7M65	BRC63AV	BRC4M61-6
		Wired			BRC4M150W16				BRC4M150W16	
2	Navigation remote controller (Wired remote controller)			BRC1E63				BRC2E61		
3	Simplified remote controller (Exposed type)							BRC1E63 Note 7		
4	Remote controller for hotel use (Concealed type)									BRC2C51
5	Adaptor for wiring				★KRP1C63	★KRP1BA57		★KRP1B61	KRP1B61	★KRP1B56
6-1	Wiring adaptor for electrical appendices (1)				★KRP2A62	★KRP2A62		★KRP2A61	KRP2A61	★KRP2A53
6-2	Wiring adaptor for electrical appendices (2)				★KRP4AA53	★KRP4AA53	★KRP4AA53	★KRP4AA51	KRP4AA51	★KRP4A54
7	Remote sensor (for indoor temperature)				KRCS01-4B			KRCS01-1B		
8	Installation box for adaptor PCB ☆				Note 2, 3 KRP1H98	Note 4, 6 KRP1BA101	KRP1BA97	Note 2, 3 KRP1B96		Note 4, 6 KRP1BA101
9	External control adaptor for outdoor unit				★DTA104A62	★DTA104A62		★DTA104A61	DTA104A61	★DTA104A53
10	Adaptor for multi tenant				★DTA114A61					

No.	Item	Type		FXMQ-P/ FXMQ-ARV	FXMQ-NVE	FXHQ-MA/AVM	FXAQ-A	FXLQ-MA FXNQ-MA	FXVQ-N
		Wireless	Receiver Handset						
1	Remote controller	Wireless	Receiver Handset	BRC4M61-6		BRC7EA63W9 /BRC7M53	BRC7N618-6	BRC4M61-6	
		Wired		BRC4M150W16			BRC4M150W16		
2	Navigation remote controller (Wired remote controller)					BRC1E63 Note 7			BRC2E61 Note 8
3	Wired remote controller with weekly schedule timer					BRC1D61			BRC1E63 Note 9
4	Simplified remote controller (Exposed type)			BRC2C51	BRC2C51			BRC2C51	
5	Remote controller for hotel use (Concealed type)			BRC3A61	BRC3A61			BRC3A61	
6	Adaptor for wiring			★KRP1C64	KRP1B61	KRP1BA54		KRP1B61	KRP1C67
7-1	Wiring adaptor for electrical appendices (1)			★KRP2A61	KRP2A61	★KRP2A61	★KRP2A61	KRP2A61	
7-2	Wiring adaptor for electrical appendices (2)			★KRP4AA51	KRP4AA51	★KRP4AA52	★KRP4AA52	KRP4AA51	KRP2A62
8	Remote sensor (for indoor temperature)						KRCS01-1B		
9	Installation box for adaptor PCB ☆			Note 1 KRP4A96		Note 3 KRP1CA93	Note 1 KRP4AA93		
10	External control adaptor for outdoor unit			★DTA104A61	DTA104A61	★DTA104A62	★DTA104A61	DTA104A61	DTA104A62
11	Adaptor for multi tenant			★DTA114A61			★DTA114A61		
12	External control adaptor for cooling / heating								KRP6A1
13	Remote controller with key								KRC837-1

#### Function List

		Round Flow with Sensing Type
		FXFSQ-A
Remote controller	Wired	BRC1E63
	Wireless	—
Dual sensors *1		○
Direct airflow *1		○
Sensing sensor low mode *1		○
Sensing sensor stop mode *1		○
Circulation airflow		○
Individual airflow direction control		○
Switchable 5 step fan speed		○
Auto-airflow rate		○
Auto-swing		○
Swing pattern selection		○
High ceiling application		○

#### Notes:

1. Installation box ☆ is necessary for each adaptor marked ★.
2. Up to 2 adaptors can be fixed for each installation box.
3. Only one installation box can be installed for each indoor unit.
4. Up to 2 installation boxes can be installed for each indoor unit.
5. Installation box ☆ is necessary for second adaptor.
6. Installation box ☆ is necessary for each adaptor.
7. Individual airflow direction, auto airflow rate and sensing sensor control can be set only via wired remote controller BRC1E63. Cannot be set via other remote controllers.
8. Since the control panel is equipped as standard, use the option for 2 remote control system.
9. When using BRC1E63, be sure to remove the control panel and since BRC1E63 cannot be stored inside the indoor unit, please place it separately.

For Control			Model
Remote controller (for grid ceiling panel)	Wireless	Heat Pump	BRC7M530W
Remote controller (for decoration panel)	Wireless	Heat Pump	BRC7E530W
Navigation remote controller			BRC1E63
Simplified remote controller			BRC2E61
Adaptor for wiring (operation status output)			★BRP11B62
Wiring adaptor for electrical appendices (1)			★KRP2A62
Wiring adaptor for electrical appendices (2)			★KRP4AA53
Remote sensor (for indoor temperature)			BRC501A-5
Installation box for adaptor printed circuit board*2			KRP1BB101 (Note 3, 4)
External control adaptor for outdoor unit			★DTA104A62
Multi tenant unit (24V free type) for indoor			★BRP114A61

## System Configuration

No.	Item	Type	Model No.	Function
1	Residential central remote controller		Note 2 DCS303A51	• Up to 16 groups of indoor units (128 units) can be easily controlled using the large LCD panel. ON/OFF, temperature settings and scheduling can be controlled individually for indoor units.
2	Central remote controller		DCS302CA61	• Up to 64 groups of indoor units (128 units) can be connected, and ON/OFF, temperature setting and monitoring can be accomplished individually or simultaneously. Connectable up to 2 controllers in one system.
2-1	Electrical box with earth terminal (3 blocks)		KJB311AA	
3	Unified ON/OFF controller		DCS301BA61	• Up to 16 groups of indoor units (128 units) can be turned, ON/OFF individually or simultaneously, and operation and malfunction can be displayed. Can be used in combination with up to 8 controllers.
3-1	Electrical box with earth terminal (2 blocks)		KJB212AA	
3-2	Noise filter (for electromagnetic interface use only)		KEK26-1A	
4	Schedule timer		DST301BA61	• Programmed time weekly schedule can be controlled by unified control for up to 64 groups of indoor units (128 units). Can turn units ON/OFF twice per day.
5	5-room centralised controller for residential indoor units	For CDXS, FDK(X)S, FTK(X)S	Note 3 KRC72A	• Up to 5 indoor units can be controlled. This is a low cost system which can only control ON/OFF.
6	Interface adaptor for residential indoor units	For CDXS, FDK(X)S, FTK(X)S	KRP928BB2S	• Adaptors required to connect products other than those of the VRV System to the high-speed DIII-NET communication system adopted for the VRV System.
7	Interface adaptor for SkyAir-series	For FCQ-B, FFQ-B, FHQ-BV, FBQ-B	★DTA112BA51	
8	Central control adaptor kit	For UAT(Y)-K(A), FD-K	★DTA107A55	
9	Wiring adaptor for other air-conditioner		★DTA103A51	
10	DIII-NET Expander Adaptor		DTA109A51	• Up to 1024 units can be centrally controlled in 64 different groups. • Wiring restrictions (max. length: 1,000m, total wiring length: 2,000m, max. number of branches: 16) apply to each adaptor. • Fixing plate for DTA109A51
10-1	Mounting plate		KRP4A92	

- Note:** 1. Installation box for ★ adaptor must be obtained locally.  
2. For residential use only. Cannot be used with other centralised control equipment.  
3. A wiring adaptor (KRP413AB1S) is also required for each indoor unit.

## Building Management System

No.	Item				Model No.	Function	
1	Intelligent Touch Controller	Basic	Hardware	Intelligent Touch Controller	DCS601C51	• Air conditioning management system that can be controlled by a compact all-in-one unit.	
1-1		Option	Hardware	DIII-NET plus adaptor	DCS601A52	• Additional 64 groups (10 outdoor units) is possible.	
1-2	Electrical box with earth terminal (4 blocks)				KJB411A	• Wall embedded switch box.	
2	Intelligent Touch Manager	Basic	Hardware	Intelligent Touch Manager	DCM601B51	• Air conditioning management system that can be controlled by touch screen.	
2-1		Option	Hardware	iTM plus adaptor	DCM601A52	• Additional 64 groups (10 outdoor units) is possible. Max. 7 iTM plus adaptors can be connected to Intelligent Touch Manager.	
2-2				iTM power proportional distribution	DCM002A51	• Power consumption of indoor units are calculated based on operation status of the indoor unit and outdoor unit power consumption measured by kWh metre.	
2-3			Software	iTM energy navigator	DCM008A51	• Building energy consumption is visualised. Wasted air conditioning energy can be found out.	
2-4							
2-5	Di unit					DEC101A51	• 8 pairs based on a pair of ON/OFF input and abnormality input.
2-6	Dio unit					DEC102A51	• 4 pairs based on a pair of ON/OFF input and abnormality input.
3	Communication interface	*1 Interface for use in BACnet®			DMS502B51	• Interface unit to allow communications between VRV and BMS. Operation and monitoring of air conditioning systems through BACnet® communication.	
3-1		Optional DIII board			DAM411B51	• Expansion kit, installed on DMS502B51, to provide 2 more DIII-NET communication ports. Not usable independently.	
3-2		Optional Di board			DAM412B51	• Expansion kit, installed on DMS502B51, to provide 16 more wattmeter pulse input points. Not usable independently.	
4		*2 Interface for use in LONWORKS®			DMS504B51	• Interface unit to allow communications between VRV and BMS. Operation and monitoring of air conditioning systems through LonWorks® communication.	
5		Home Automation Interface Adaptor			DTA116A51	• Use of the Modbus protocol enables the connection of the VRV system with a variety of home automation systems from other manufacturers.	

- Notes:**  
\*1. BACnet® is a registered trademark of American Society of Heating, Refrigerating and Air-Conditioning Engineers (ASHRAE).  
\*2. LonWorks® is a trademark of Echelon Corporation registered in the United States and other countries.  
\*3. Installation box for ★ adaptor must be obtained locally.



## The Innovative Refrigerant Piping of next generation.

Daikin innovated next generation of quality and efficiency for VRV installation. It offers differentiated solutions in installation. It ensures quality installation with reduction of site work.



Header Pack

### Advantage

- Installation time saving: Up to 1/3 of conventional method.
- Easy to Install: Hanging points available.
- Safety: Consists of flaring method, no brazing required\*.
- Space saving: Header pack to Indoor unit soft drawn pipe, top side of refrigerant pipe doesn't need space for brazing torch movement.
- Quality Installation: Elimination of difficult process, enhancing quality installation.

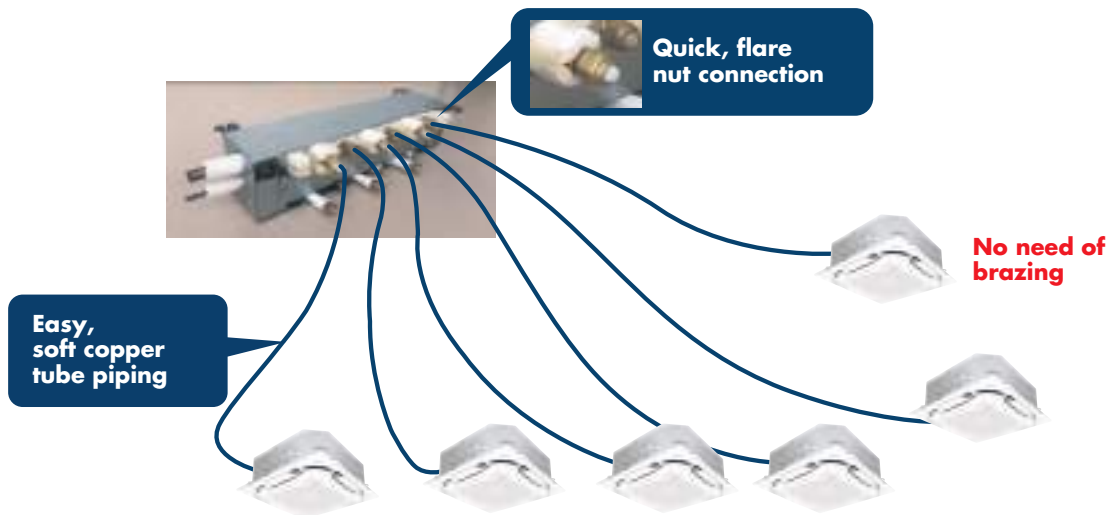

### Compact design to fit into narrow attic space

Light weight and the compact body give minimum damage on the building structure.

### Header Pack Line-up

Model Name	HP	Piping connections (Liquid/Gas mm)		Indoor unit total capacity index
		Outdoor unit side	Indoor unit side	
BHF6RHP6	6	Φ9.5/Φ15.9	(Φ9.5/Φ15.9)×1 (Φ6.4/Φ12.7)×3	<150
BHF8RHP6	8	Φ9.5/Φ19.1	(Φ9.5/Φ15.9)×3 (Φ6.4/Φ12.7)×3	150 ≤ X < 200
BHF10RHP6	10	Φ9.5/Φ22.2		200 ≤ X < 290
BHF16RHP6	16	Φ12.7/Φ28.6		290 ≤ X < 420



# DAIKIN GAS TIGHT JOINT (DGT)

## Non-brazed connection for Refrigerant piping

### Evolutionally - Advanced Feature

A combination of rubber packing and screwed metal body offers gas-tight and rigid connection without brazing. Patented "Leverage Method" mechanically holds the pipe and prevents it from pull-out.



Size  $\phi$  6.4 -  $\phi$  41.3

### Mechanism

Daikin DGT is a non-brazed connection suitable for piping. Pipes can be joined easily and quickly without brazing or using any special tools. It meets stringent safety requirements and provides leak-free tightness among various substantial benefits.

- Double edged claw catches the pipe to form tight mechanical sealing.
- 3 types of connectors suitable for most pipe sizes and applications.
- Unique mechanical and resin sealing prevent gas leak completely.
- It is durable up to 4 times (17.2MPa) of max. operating pressure.

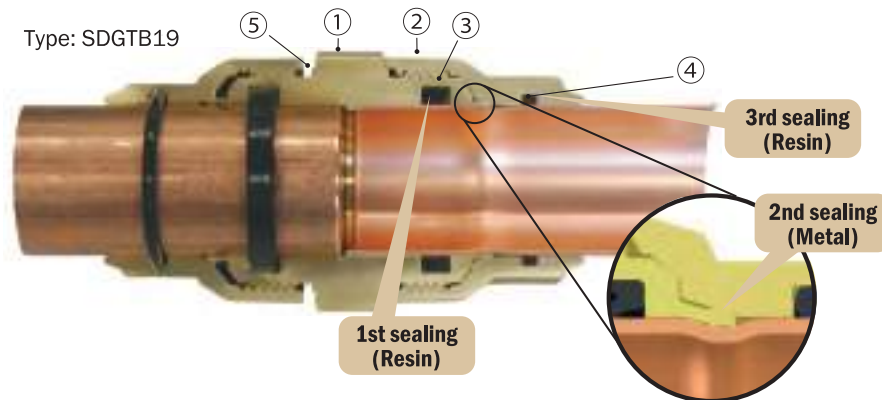

### System Reliability

- No risk of copper oxide or soot in pipes due to no brazing.
- Prevents early compressor failure and prolongs the lifespan of air-conditioners.

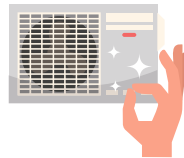

### Safety First

- As no brazing is required, fire hazards are completely eliminated during installation on site.
- No risk of handling high pressure and flammable gas.



### Time & Costs Savings



- No need to apply for hot work permit or station fire safety watchers onsite, thus saving time and cost with less administrative work.
- Simple installation process also reduces installation time.



## Daikin Gas Tight Joint Line up

(Matching for various piping sizes)

### Standard Joints (Connecting the same pipes)

Figure	Model Name	Dimension (mm)			Weight /pc (g)
		ND	AF	L	
	SDGTB06	φ 6.4	19.0	50.4	43
	SDGTB09	φ 9.5	22.2	55	79
	SDGTB12	φ 12.7	23.8	59	113
	SDGTB15	φ 15.9	29.7	74	210
	SDGTB19	φ 19.1	35.0	76.8	273
	SDGTB22	φ 22.2	38.0	83.4	292
	SDGTB28	φ 22.6	45.0	88	515
	BDGTA34	φ 34.9	51.1	101.5	686
	BDGTA41	φ 41.3	58.3	103.5	881

### Asymmetry Joints (Connecting different size pipes)

Figure	Model Name	Dimension (mm)			Weight /pc (g)	
		ND	AF	L		
	SDGTB0906	φ 9.5-6.4	22.2	19	52.7	67
	SDGTB1209	φ 12.7-9.5	23.8	22.2	57.5	101
	SDGTB1512	φ 15.9-12.7	29.7	23.8	65	164
	SDGTB1915	φ 19.1-15.9	35	29.7	76.8	244
	SDGTB2219	φ 22.2-19.1	38	35	81.5	358
	SDGTB2522	φ 25.2-22.2	41.8	38	85.8	444
	SDGTB2825	φ 28.6-25.4	45	41.8	88.1	505
	SDGTB3428	φ 34.9-28.6	51.1	45	101.5	645

# AIR TREATMENT EQUIPMENT LINE-UP

Our air treatment systems  
create a higher air quality  
environment

## Components of Indoor Air Quality

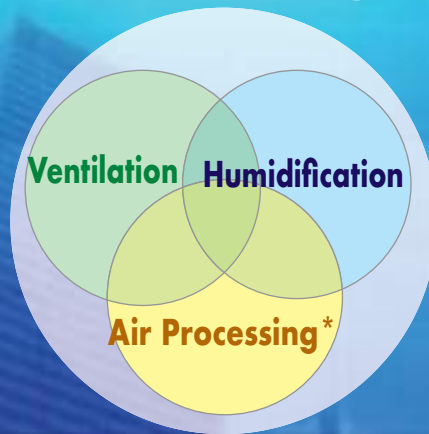

\*Refers to bringing outdoor air to near indoor temperature and delivering to a room.

A recent trend rapidly gaining popularity is the need for air treatment along with air conditioning. Our Outdoor Air Processing Unit can combine fresh air treatment and air conditioning, supplied from a single system. It adjusts the temperature of air from outdoors using a fixed discharge temperature control. Along with Outdoor Air Processing Units, we also offer Heat Reclaim Ventilator systems. The Heat Reclaim Ventilator VAM-GJ series units in particular have been praised for their compactness, energy conservation and extensive operation range of outdoor temperatures. This series provides higher enthalpy efficiency due to the greatly enhanced performance of the thin film element. Furthermore, improved external static pressure offers more flexibility for installation. The Heat Reclaim Ventilator VKM-GAM series units, equipped with a DX-coil and a humidifier, provide further advanced features, such as temperature adjustment to suit conditions indoors and to prevent cold air from blowing on people directly during heating operation. The series also realises significant energy savings by exercising heat recovery.

		Outdoor Air Processing Unit	Heat Reclaim Ventilator		
			VKM-GAM Type	VKM-GA Type	VAM-GJ Type
Connections with VRV X	Refrigerant Piping	Connectable	Connectable	Connectable	Not connectable
	Wiring	Connectable	Connectable	Connectable	Connectable
	After-Cool & After-Heat Control	Available	Available	Available	Not available
Heat Exchange Element		—	Energy savings obtained		Energy savings obtained
Humidifier		—	Fitted	—	—
High Efficiency Filter		Option	Option		Option
Ventilation System		Air supply only	Air supply & air exhaust		Air supply & air exhaust
Power Supply		220-240 V, 50 Hz	220-240 V, 50 Hz		220-240 V/220 V, 50 Hz
Airflow Rate					250 m <sup>3</sup> /h
				500 m <sup>3</sup> /h	500 m <sup>3</sup> /h
				800 m <sup>3</sup> /h	650 m <sup>3</sup> /h
				1000 m <sup>3</sup> /h	800 m <sup>3</sup> /h
		1260 m <sup>3</sup> /h			1000 m <sup>3</sup> /h
		1740 m <sup>3</sup> /h			1500 m <sup>3</sup> /h
		2340 m <sup>3</sup> /h			2000 m <sup>3</sup> /h

\*Refers to bringing outdoor air to near indoor temperature and delivering to a room.

## Outdoor Air Processing Unit

Combination of fresh air treatment and air conditioning, supplied from a single system.

### Lineup

Model Name	FXMQ125NFRV16	FXMQ200NFRV16	FXMQ250NFRV16
Capacity Index	125	200	250



Fresh air treatment and air conditioning can be achieved with a single system by using the heat pump technology - without the usual troublesome air supply and air discharge balance design. Fan coil units for air conditioning and an outdoor-air processing unit can be connected to the same refrigerant line. The results are enhanced design flexibility and a significant reduction in total system costs.

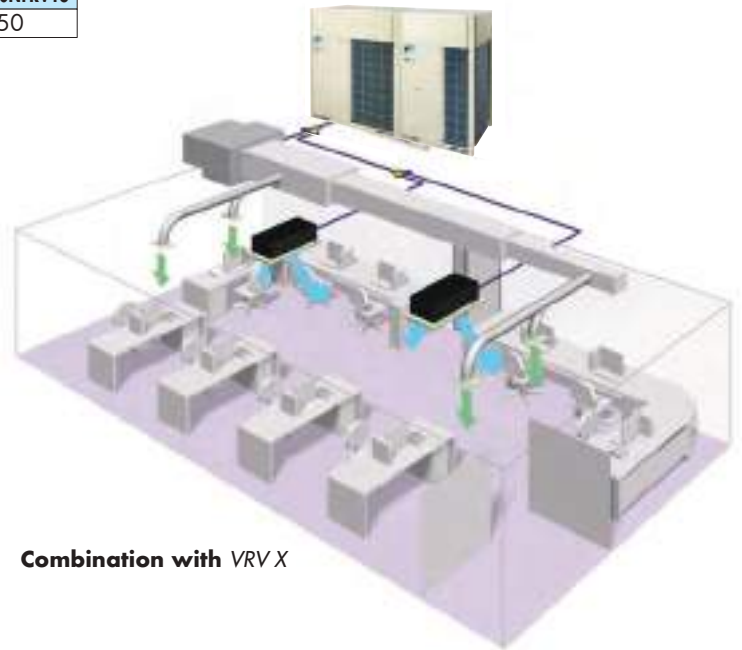

Combination with VRV X

Air conditioning and outdoor air processing can be accomplished using a single system.

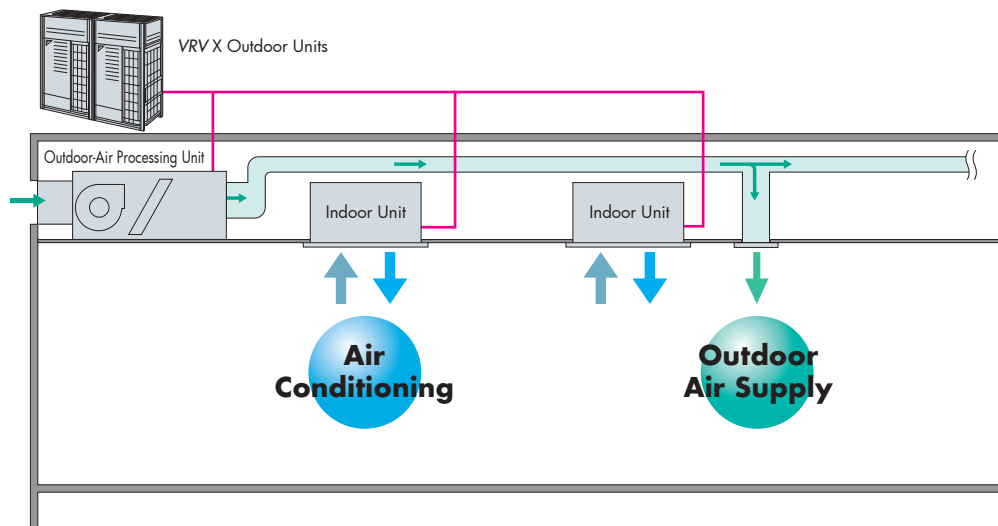

### Connection Conditions

The following restrictions must be observed in order to maintain the indoor units connected to the same system.

- When outdoor-air processing units are connected, the total connection capacity index must be 50% to 100% of the capacity index of the outdoor units.
- When outdoor air processing units and standard indoor units are connected, the total connection capacity index of the outdoor air processing units must not exceed 30% of the capacity index of the outdoor units.
- Outdoor air processing units can be used without indoor units.

## Standard Specifications

### Indoor unit

Type		Ceiling Mounted Duct Type			
Model		FXMQ125NFRV16	FXMQ200NFRV16	FXMQ250NFRV16	
Power supply		1-phase 220-240 V (also required for indoor units), 50 Hz			
Cooling capacity *1	kcal/h	12,000	19,300	24,100	
	Btu/h	47,800	76,400	95,500	
	kW	14.0	22.4	28.0	
Heating capacity *1	kcal/h	7,700	12,000	15,000	
	Btu/h	30,400	47,400	59,400	
	kW	8.9	13.9	17.4	
Casing		Galvanised steel plate			
Dimensions (HXWXD)		mm	440 x 1190 x 1090	440 x 1190 x 1090	
Fan	Motor output	kW	0.75		
	Airflow rate	m <sup>3</sup> /min	21	29	39
		cfm	741	1,024	1,377
External Static Pressure with Filter (PM10+PM50)	220 V/240 V	Pa	300	260	240
Refrigerant piping	Liquid	mm	ø9.5 (flare)		
	Gas	mm	ø15.9 (flare)	ø19.1 (brazing)	ø22.2 (brazing)
	Drain	mm	PS1B female thread		
Machine weight		k g	115		
Sound level *3	220 V/240 V	dBA	48	50	52
Connectable outdoor units *4 *5			6 HP and above		10 HP and above

Notes: \*1. Specifications are based on the following conditions;

- Cooling: Outdoor temp. of 33°CDB, 28°CWB (68% RH), and discharge temp. of 18°CDB.
- Equivalent reference piping length: 7.5 m (0 m horizontal)
- \*2 An intake filter is not supplied, so be sure to install the optional long-life filter or high-efficiency filter. Please mount it in the duct system of the suction side. Select a dust collection efficiency (gravity method) of 50% or more.
- \*3 Anechoic chamber conversion value, measured at a point 1.5 m downward from the unit centre. These values are normally somewhat higher during actual operation as a result of ambient conditions.
- \*4 It is possible to connect to the outdoor unit if the total capacity of the indoor units is 50% to 100% of the capacity index of the outdoor units.
- \*5 Local setting mode. Not displayed on the remote controller.
  - This equipment cannot be incorporated into the remote group control of the VRV X system.

## Heat Reclaim Ventilator with DX-Coil and Humidifier-VKM Series



For More information  
'Scan Me'

The Heat Reclaim Ventilator lineup features the DX-coil in response to recently diversifying outdoor air introduction requirements.

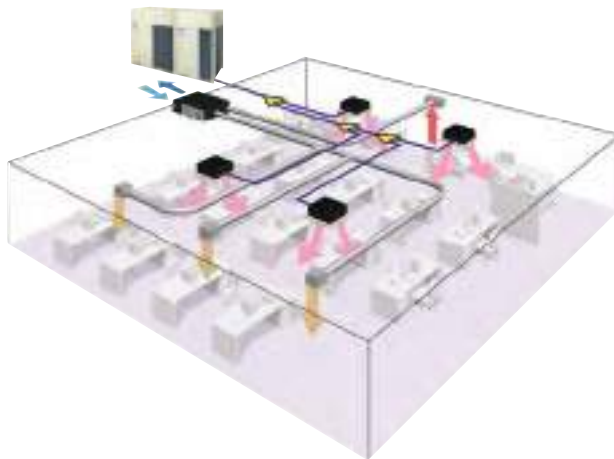

### Line-up

	With DX Coil & Humidifier Type		
Model Name	VKM50GAMV1	VKM80GAMV1	VKM100GAMV1
Capacity Index	31.25	50	62.5

	With DX Coil Type		
Model Name	VKM50GAV1	VKM80GAV1	VKM100GAV1
Capacity Index	31.25	50	62.5

VKM80GAV1



### Humidifier

The line-up includes models with a humidifier, in response to diversifying customer requirements. (VKM50/80/100GAMV1 only)

### DX-coil

The Heat Reclaim Ventilator features DX-coil that contributes to the prevention of cold airflow hitting people directly during heating operation, due to the after-cool, after-heat operations done beforehand.

### Efficient outdoor air introduction is possible

The Heat Reclaim Ventilator (VKM series) series introduces fresh outdoor air with minimum heat losses, while a wide variety of features responds to customer requirements.

### High static pressure

High external static pressure means enhanced design flexibility.

## Air conditioning and outdoor air processing can be accomplished using a single system.

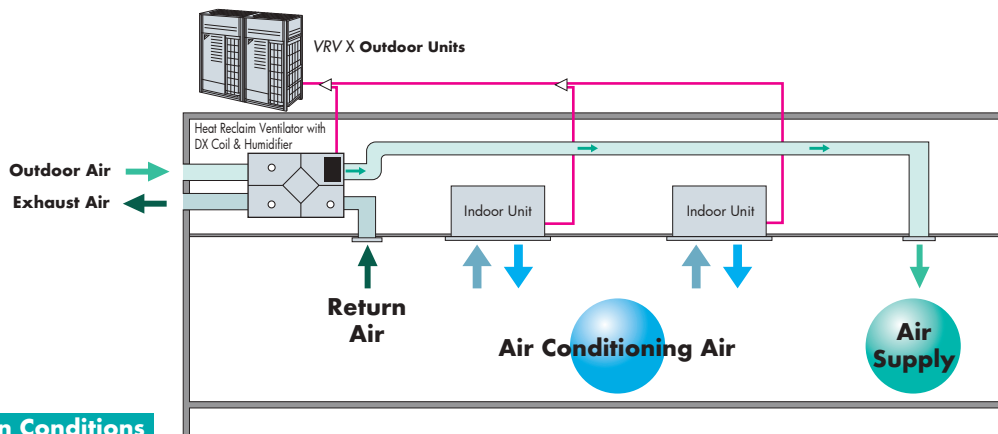

### Connection Conditions

The following restrictions must be observed in order to maintain the indoor units connected to the same system.

- When the Heat Reclaim Ventilator VKM series units are connected, the total connection capacity index must be 50% to 130% of the capacity index of the outdoor units.

## A compact unit packed with our cutting-edge technology

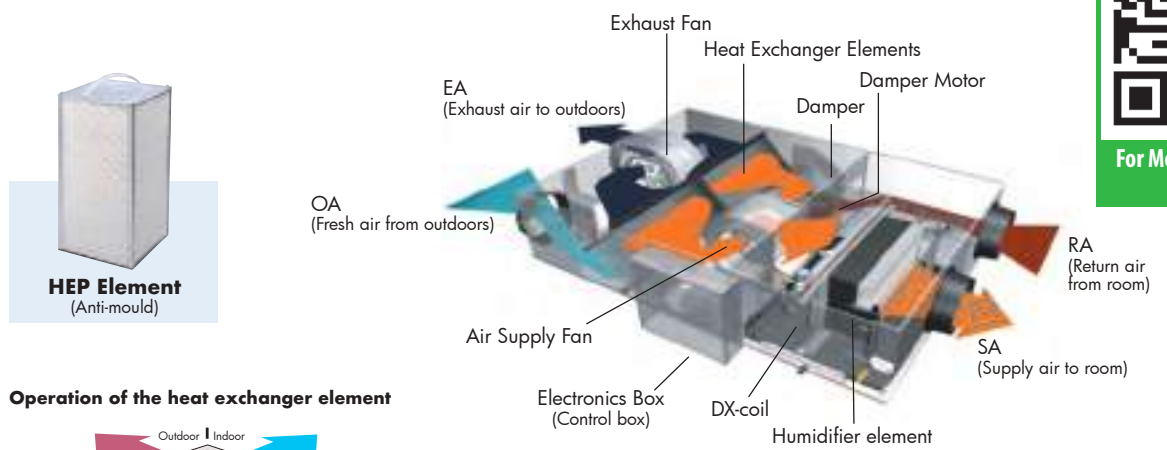

### Operation of the heat exchanger element

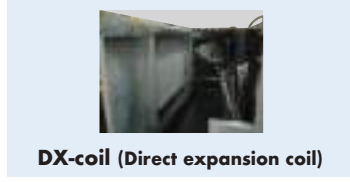
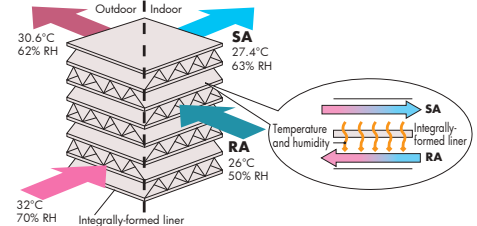

## Heating and humidification process

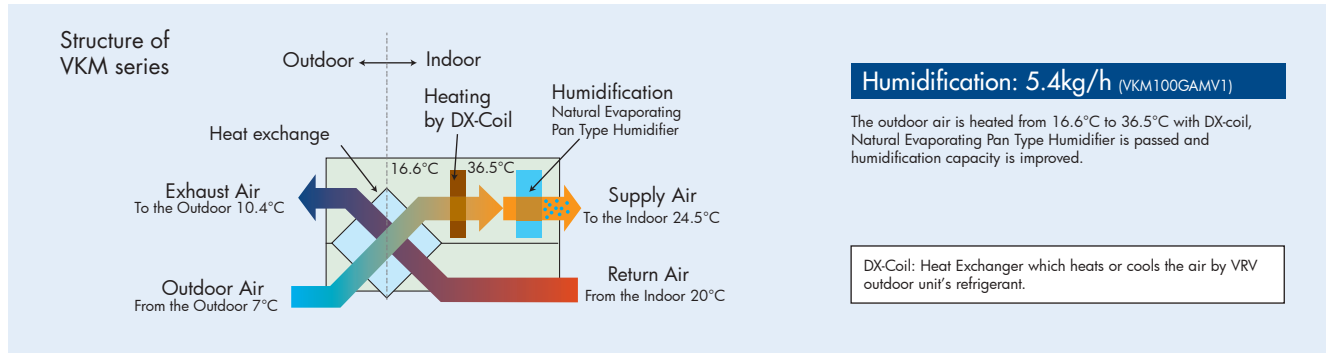

## Efficient outdoor air introduction with heat exchanger and cooling/heating operations

### Indoor unit with outdoor air treatment

Using outdoor air, the temperature can be brought near room temperature with minimal cooling capacity through the use of outdoor air.

### Other features

- Integrated system includes ventilation and humidifying operations.
- Ventilation, cooling/heating and humidifying are possible with one remote controller.

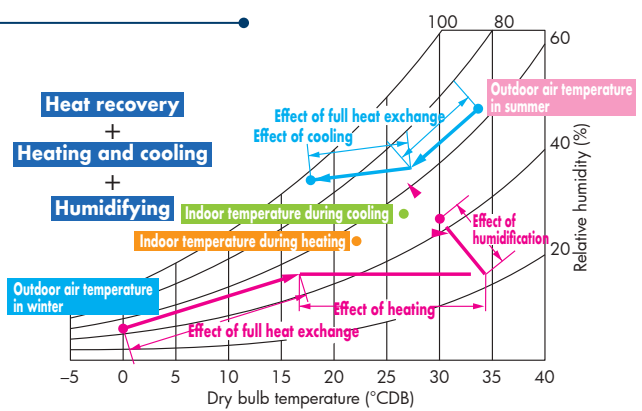

# AIR TREATMENT EQUIPMENT LINE-UP

## Specifications

MODEL				VKM50GAMV1*	VKM80GAMV1*	VKM100GAMV1*	VKM50GAV1	VKM80GAV1	VKM100GAV1
Refrigerant				R-410A					
Power Supply				1-phase, 220-240 V, 50 Hz					
Airflow Rate & Static Pressure (Note 7)	Ultra-high	Airflow rate	m <sup>3</sup> /h	500	750	950	500	750	950
		Static pressure	Pa	160	140	110	180	170	150
	High	Airflow rate	m <sup>3</sup> /h	500	750	950	500	750	950
		Static pressure	Pa	120	90	70	150	120	100
	Low	Airflow rate	m <sup>3</sup> /h	440	640	820	440	640	820
		Static pressure	Pa	100	70	60	110	80	70
Power Consumption	Heat exchange mode	Ultra-high	W	560	620	670	560	620	670
		High	W	490	560	570	490	560	570
		Low	W	420	470	480	420	470	480
	Bypass mode	Ultra-high	W	560	620	670	560	620	670
		High	W	490	560	570	490	560	570
		Low	W	420	470	480	420	470	480
Fan Type				Sirocco Fan					
Motor Output				kW					
				0.280 x 2	0.280 x 2	0.280 x 2	0.280 x 2	0.280 x 2	0.280 x 2
Sound Level (Note 5) (220/230/240 V)	Heat exchange mode	Ultra-high	dB(A)	37/37.5/38	38.5/39/40	39/39.5/40	38/38.5/39	40/41/41.5	40/40.5/41
		High	dB(A)	35/35.5/36	36/37/37.5	37/37.5/38	36/36.5/37	37.5/38/39	38/38.5/39
		Low	dB(A)	32/33/34	33/34/35.5	34/34.5/35.5	33.5/34.5/35.5	34.5/36/37	35/36/36.5
	Bypass mode	Ultra-high	dB(A)	37/37.5/38	38.5/39/40	39/39.5/40	38/38.5/39	40/41/41.5	40/40.5/41
		High	dB(A)	35/35.5/36	36/37/37.5	37/37.5/38	36/36.5/37	37.5/38/39	38/38.5/39
		Low	dB(A)	32/33/34	33/34/35.5	34/34.5/35.5	33.5/34.5/35.5	34.5/36/37	35/36/36.5
Humidification Capacity (Note 4)				kg/h					
				2.7	4.0	5.4	—	—	—
Temp. Exchange Efficiency	Ultra-high			76	78	74	76	78	74
	High			76	78	74	76	78	74
	Low			77.5	79	76.5	77.5	79	76.5
Enthalpy Exchange Efficiency (Cooling)	Ultra-high			64	66	62	64	66	62
	High			64	66	62	64	66	62
	Low			67	68	66	67	68	66
Enthalpy Exchange Efficiency (Heating)	Ultra-high			67	71	65	67	71	65
	High			67	71	65	67	71	65
	Low			69	73	69	69	73	69
Casing				Galvanised Steel Plate					
Insulating Material				Self-Extinguishable Urethane Foam					
Heat Exchanging System				Air to Air Cross Flow Total Heat (Sensible + Latent Heat) Exchange					
Heat Exchanger Element				Specially Processed Non-flammable Paper					
Air Filter				Multidirectional Fibrous Fleeces					
DX-coil Capacity	Cooling (Note 2)			2.8	4.5	5.6	2.8	4.5	5.6
	Heating (Note 3)			3.2	5.0	6.4	3.2	5.0	6.4
Dimensions	Height			387	387	387	387	387	387
	Width			1,764	1,764	1,764	1,764	1,764	1,764
	Depth			832	1,214	1,214	832	1,214	1,214
Connection Duct Diameter				mm					
				Ø 200	Ø 250		Ø 200	Ø 250	
Machine Weight	Net			102	120	125	96	109	114
	Gross (Note 8)			107	129	134	—	—	—
Unit Ambient Condition	Around Unit		0°C-40°C DB, 80%RH or less						
	OA (Note 9)		-15°C-40°C DB, 80%RH or less						
	RA (Note 9)		0°C-40°C DB, 80%RH or less						

- Notes:**
- Cooling and heating capacities are based on the following conditions. Fan is based on High and Ultra-high. When calculating the capacity as indoor units, use the following figures: VKM50GAMV1/GV1: 3.5 kW, VKM80GAMV1/GV1: 5.6 kW, VKM100GAMV1/GV1: 7.0 kW.
  - Indoor temperature: 27°C DB, 19°C WB, Outdoor temperature: 35°C DB.
  - Indoor temperature: 20°C DB, Outdoor temperature: 7°C DB, 6°C WB.
  - Humidifying capacity is based on the following conditions: Indoor temperature: 20°C DB, 15°C WB, Outdoor temperature: 7°C DB, 6°C WB.
  - The operating sound measured at the point 1.5 m below the centre of the unit is converted to that measured in an anechoic chamber built in accordance with the JIS C 1502 conditions. The actual operating sound varies depending on the surrounding conditions (near running unit's sound, reflected sound and so on) and is normally higher than this value.
- For operation in a quiet room, it is required to take measures to lower the sound.  
For details, refer to the Engineering Data.
- The noise level at the air discharge port is about 8-11 dBA or higher than the unit's operating sound.  
For operation in a quiet room, it is required to take measures to lower the sound.
  - Airflow rate can be changed over to Low mode or High mode.
  - In case of holding full water in humidifier.
  - OA: fresh air from outdoor. RA: return air from room.
  - Specifications, design and information here are subject to change without notice.

- Power consumption and efficiency depend on the above value of airflow rate.
  - Temperature exchange efficiency is the mean value for Cooling and Heating. Efficiency is measured under the following condition: Ratio of rated external static pressure outdoor to indoor is kept constant at 7 to 1.
  - In heating operation, freezing of the outdoor unit's coil increases. Heating capability decreases and the system goes into defrost operation. During defrost operation, the fans of the unit continue driving (factory setting). The purpose of this is to maintain the amount of ventilation and humidifying.
  - When connecting with a VRV system heat recovery outdoor unit and bringing the RA (exhaust gas intake) of this unit directly in from the ceiling, connect to a BS unit identical to the VRV indoor unit (master unit), and use group-linked operation. (See the Engineering Data for details).
  - When connecting the indoor unit directly to the duct, always use the same system on the indoor unit as with the outdoor unit, perform group-linked operation, and make the direct duct connection settings from the remote controller. (Mode No. "17 (27)" - First code No. "5" - Second code No. "6".) Also, do not connect to the outlet side of the indoor unit. Depending on the fan strength and static pressure, the unit might back up.
- ★ Feed clean water (city water, tap water or equivalent). Dirty water may clog the valve or cause dirt deposits in the water container, resulting in poor humidifier performance. (Never use any cooling tower water and heating-purpose water.) Also, if the supply water is hard water, use a water softener because of short life.
- \* Life of humidifying element is about 3 years (4,000 hours) under the supply water conditions of hardness: 150 mg/L. Life of humidifying element is about 1 year (1,500 hours) under the supply water conditions of hardness: 400 mg/L. Annual operating hours: 10 hours/day x 26 days/month x 5 months = 1,300 hours.

# Heat Reclaim Ventilator - VAM Series

## Good quality air for every day

Controlling the necessary elements will improve the quality of ventilation.

### In case of natural ventilation (Class 3)

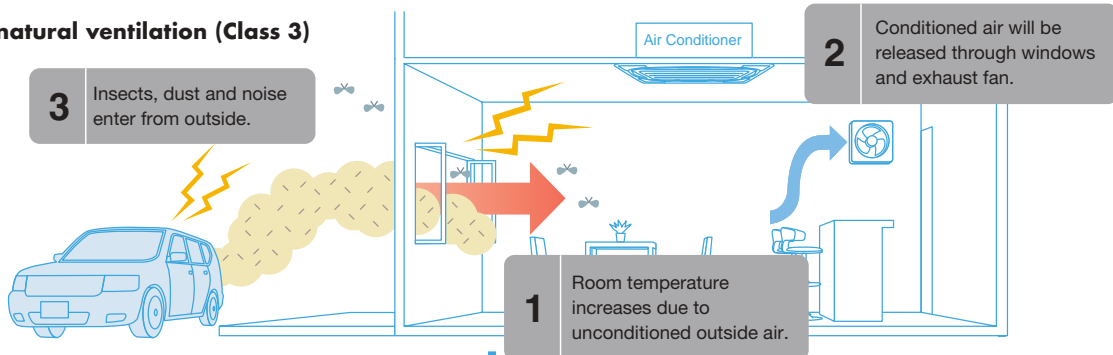

### In case of install Heat Reclaim Ventilator (VAM) (Class 1)

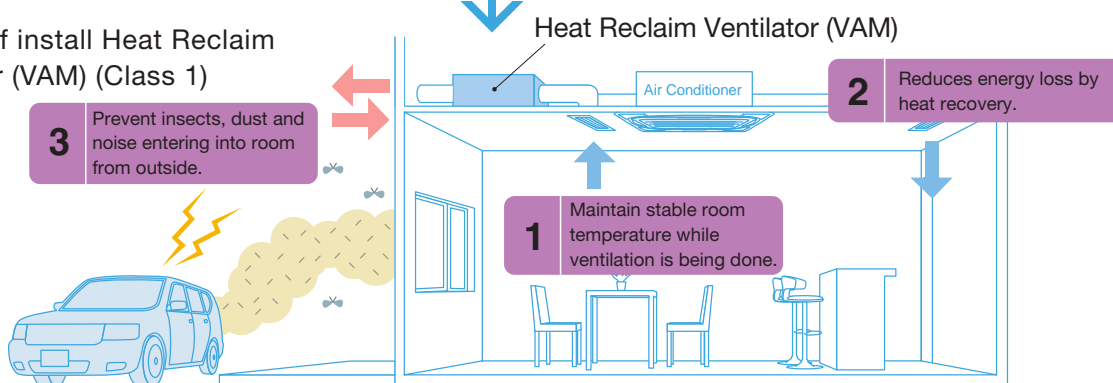

## Air conditioning load is reduced by heat recovery

### Total heat exchange ventilation

This unit recovers heat energy lost through ventilation and curbs room temperature changes caused by ventilation, thereby conserving energy and reducing the load on the air conditioning system.

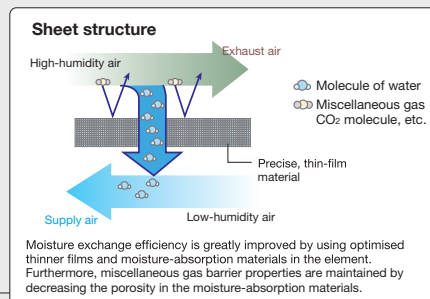
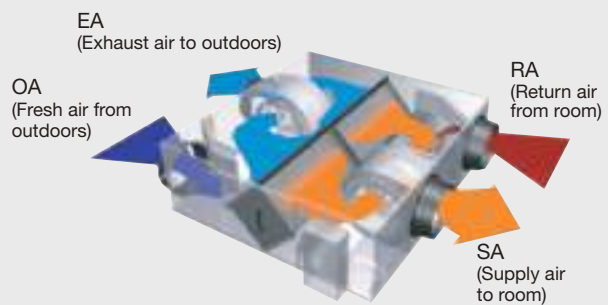
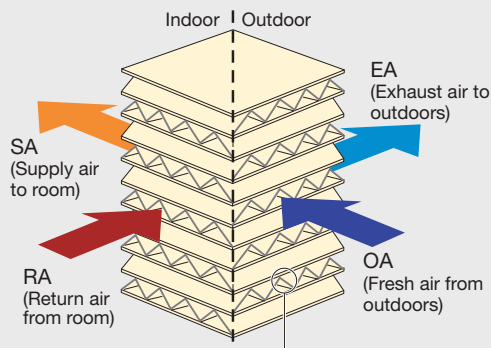

# AIR TREATMENT EQUIPMENT LINE-UP

## Airflow Control

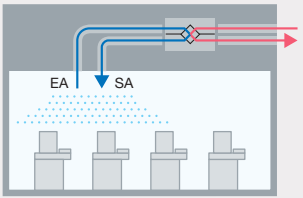
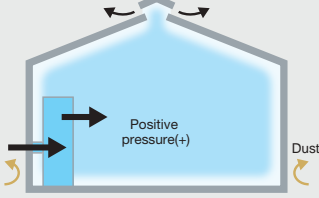
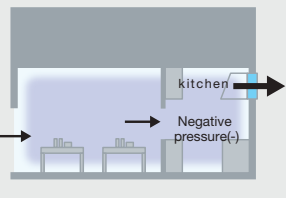
Class 1 Ventilation	Class 2 Ventilation	Class 3 Ventilation
<p>Both supply air and exhaust air are controlled by mechanical ventilation in order to achieve stable ventilation when required.</p> <p>For common ventilation usage, Class 1 ventilation is able to meet the requirement.</p>	<p>System that uses mechanical ventilation for supply air and natural ventilation for exhaust air.</p> <p>Class 2 ventilation is often used for specific purpose such as positively pressured room (Hospital Clean Room, Factory Clean Room).</p>	<p>System that uses natural ventilation for supply air and mechanical ventilation for exhaust air.</p> <p>Class 3 ventilation often being used at area with high odor generation such as kitchen and toilet.</p>
<p>“For example: Heat Reclaim Ventilator”</p>	<p>“For example: Mechanical Ventilation (Supply)”</p>	<p>“For example: Mechanical Ventilation (Exhaust)”</p>
		

## Fresh Up Operation

By changing the airflow balance, positive pressure or negative pressure in a room can be achieved in order to prevent pollutants from entering or flowing out.

**Supply fresh up operation increases the supply air volume to prevent pollutants from entering into the room.**

For example, it keeps outdoor pollen and dust from entering when doors are opened or closed, or through gaps in windows.



Example: Convenience Stores

By positive pressure in the room, the entering of dirty outside air, odors and moisture when opening and closing of doorway is prevented.

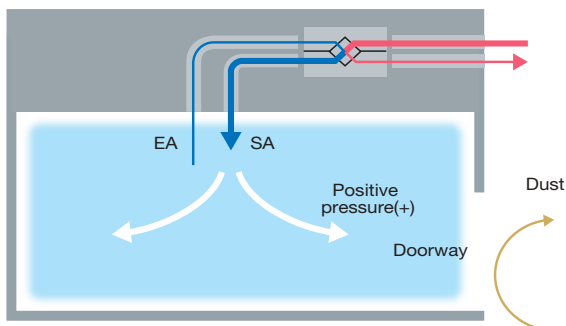

**Exhaust fresh up operation will increase exhaust air volume to prevent pollutants from flowing to other area.**

For example, to prevent dirty air generated indoors from flowing out in through windows and doors, the indoor air is kept under negative pressure and discharged.



Example: Conference Room

By negative pressure in the room, contaminated air and moisture from the room is prevented from leaking into other areas.

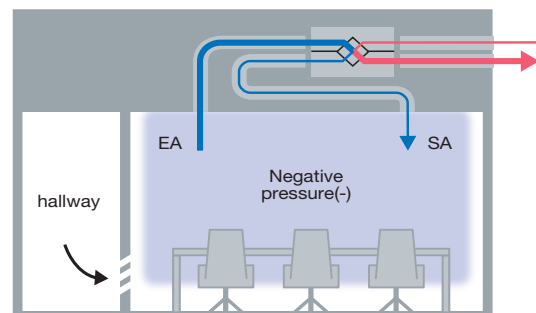

## Ventilation volume control with CO<sub>2</sub> sensor interlocking

During increase in CO<sub>2</sub> level in the room, ventilation air volume will be increased to have higher air exchange in order to reduce the CO<sub>2</sub> level in room.

Human occupancy is reflected as CO<sub>2</sub> concentration

Change in CO<sub>2</sub> concentration in conference room

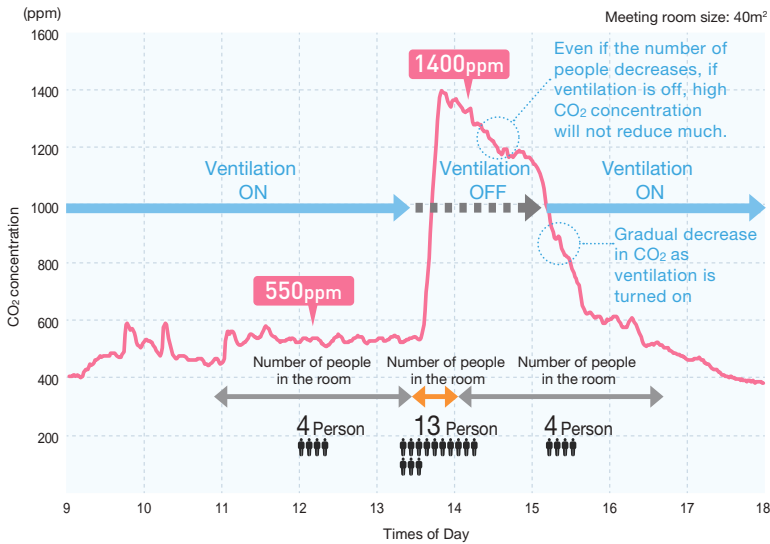

Experimental data: CO<sub>2</sub> concentration in the conference room. Closed conference rooms often tend to have stagnant air flow. In long meeting duration or meeting with full occupancy, the concentration of CO<sub>2</sub> increases due to the exhaled CO<sub>2</sub> from human and causes decrease in mind concentration. In order to achieve effective ventilation in short period, mechanical ventilation and natural ventilation should be combined to replace the air.

Image is for illustrative purpose.

## Equipped with a CO<sub>2</sub> sensor to automatically control the ventilation volume according to the CO<sub>2</sub> concentration

Low airflow when there is low occupancy.

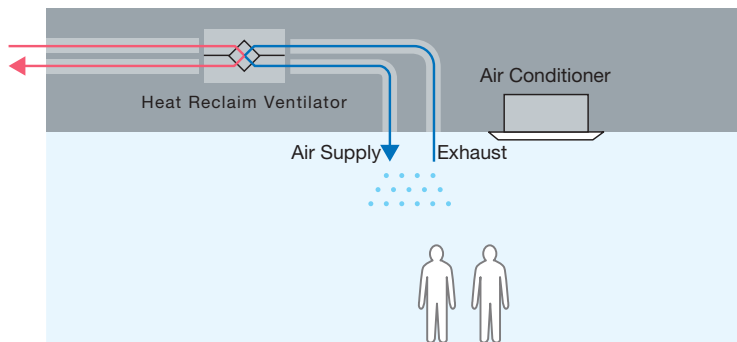

High airflow when there is an increase in occupancy.

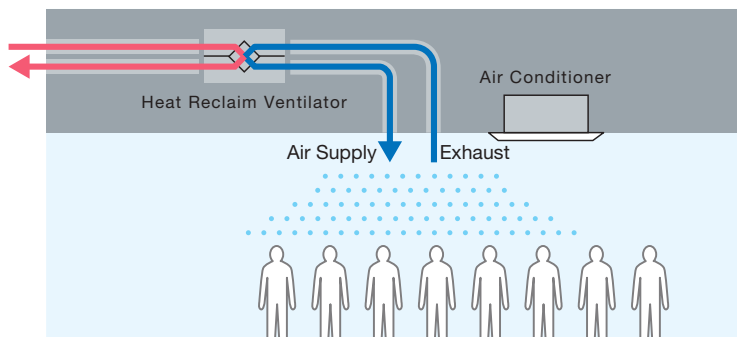

**NEW!**

New Wired Controller (BRC1H62W/K)



With the new wired controller, BRC1H62W/K, the airflow is able to be automatically controlled based on CO<sub>2</sub> concentration and CO<sub>2</sub> concentration is able to be visualized on the screen\*.

\*Optional accessory CO<sub>2</sub> sensor is required for this function.

This CO<sub>2</sub> sensor cannot be used as CO<sub>2</sub> measurement tool. CO<sub>2</sub> concentration value will be subject to change depending on the room condition and environment.

# AIR TREATMENT EQUIPMENT LINE-UP

## Energy Saving Ventilation (interlocked with air conditioner)

**Air conditioner and ventilation system can be interlocked to provide even greater comfort and energy saving.**

The system can be interlocked with Daikin air conditioners to provide energy saving ventilation solution for various situation.



## Sensing Sensor Stop Mode

**In situation of no human occupancy detection, the operation is turned off.**

When the "Sensing sensor" installed on the air conditioner detects no occupancy in the room, the ventilation system and air conditioner system is turned off automatically to reduce energy wastage.

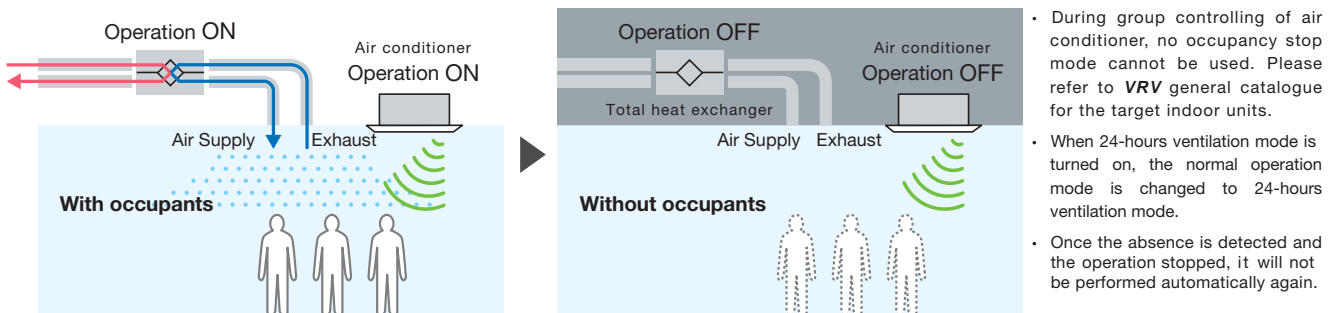

## Pre-Cooling/Pre-Heating Control

**The operation of ventilation system is delayed during this mode.**

During first start up of the air conditioner, the start up operation of ventilation system is delayed in order to reduce additional heat load from outside air. This will reduce power consumption for the air conditioner as well.

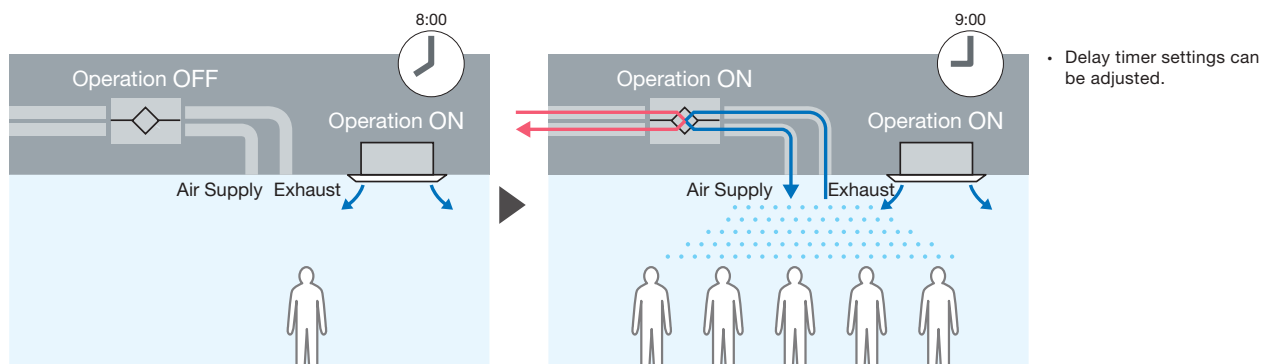

## Auto-Ventilation Mode Changeover Switching

Automatically switches the ventilation mode (Total Heat Exchange Mode/Bypass Mode) according to the operating status of the air conditioner.

When the cooling operation is required in winter, use of heat recovery ventilation is not efficient because the outdoor air temperature is normally lower than that of the indoor. Thus, the proper use of ventilation mode enhances the heating / cooling efficiency.

In addition, by installing a humidity sensor (optional), automatic switching by heat (energy) or discomfort index is possible which further improves energy efficiency and comfort.

### Total Heat Exchange Mode

(Cooling operation in summer/Heating operation in winter)

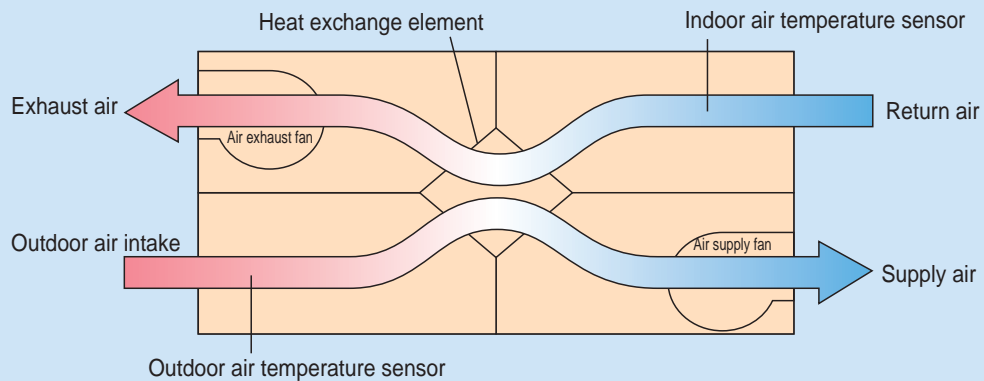

### Bypass Mode ("Intermediate" season)

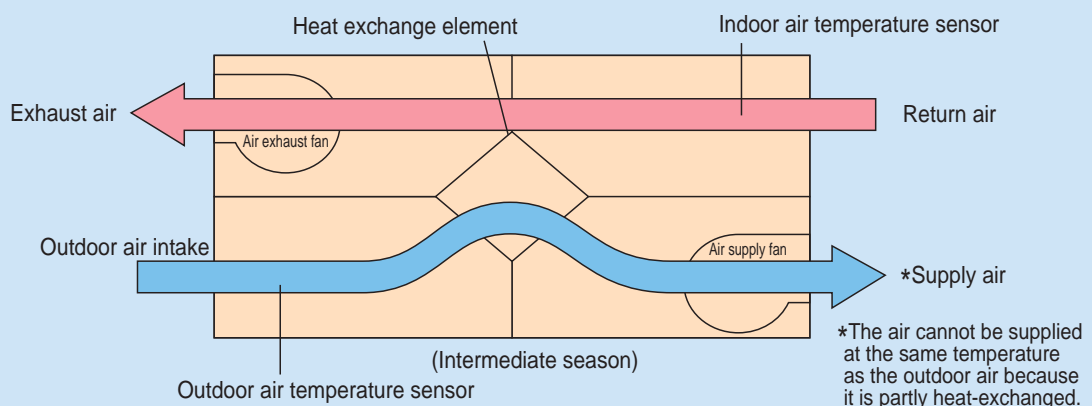

# AIR TREATMENT EQUIPMENT LINE-UP

## Night time free cooling operation

Night time free cooling operation is an energy-conserving function that works at night when air conditioners are off. By ventilating rooms containing office equipment that raises the room temperature, night time free cooling operation reduce the cooling load when air conditioners are turned on in the morning. It also alleviates feelings of discomfort in the morning caused by heat accumulated during the night.

- When connected to air conditioners, operation of heat reclaim ventilator is controlled according to the set temperature, outside air temperature and room temperature.
- When using only ventilation unit, operation of heat reclaim ventilator is controlled according to the set temperature on remote controller.
- Night time free cooling operation is possible during air conditioners linked operation by centralized control.
- Night time free cooling operation is set to "off" in the factory settings, so if there is a need to turn on, please contact Daikin dealer.

The indoor accumulated heat is discharged at night.

This reduces the air conditioning load the next day, thereby increasing efficiency.

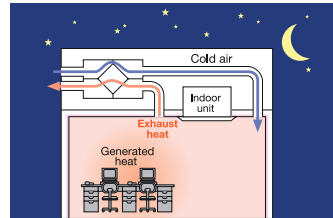

Heat is discharged.

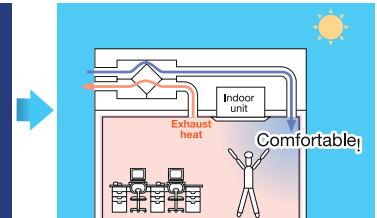

The load is small so the temperature is rapidly reduced to a comfortable level.

\*Interlocked operation with an air conditioner.

## Improved Installation Method

1. Improved installation process by changing the dimension and shape of hanging bracket.
  - The nut dropout prevention structure eliminates the need to replace the hanging bracket even when mounting upside down.
  - It also prevents the anti-vibration hanging bracket from interfering with the equipment.
2. Improved duct installation process with new duct connector location.
  - The duct connector is adjusted to be parallel to each other in order to ease duct installation process.
3. Improves controllability by input / output signals and simplifies various wiring work.
  - Operation, ventilation volume, and ventilation mode can be switched by external contact input.
  - Output signal terminal for external dampers.
  - Output signal terminal for abnormal signals and filter signs.

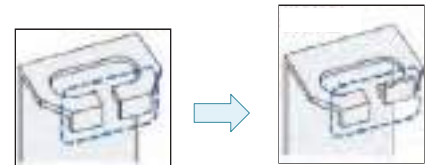

## Application Example

Ventilation related points to be taken into note during designing stage.

### Restaurant

#### Problem

- The entrance door is difficult to open.
- The food smell leaks to dining area.
- Hot outside air is coming in when the entrance door is opened.



Regardless of the industry, the cause of difficulty in opening doors may be due to insufficient air supply (ventilation).

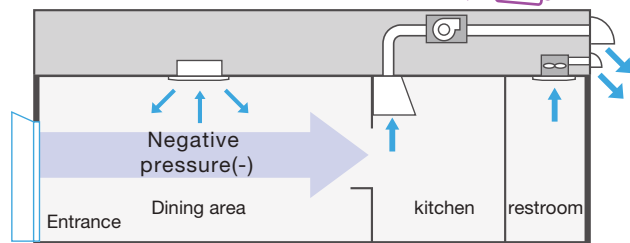

The restaurant has negative room pressure due to insufficient supply air. When the entrance door is opened, outside air enters into the restaurant bringing warm air and pollutants.

#### Countermeasure plan

1. Separate ventilation for kitchen and customer dining area.
2. Provide an air supply vent in the kitchen.
3. Install a Heat Reclaim Ventilator in the dining area.

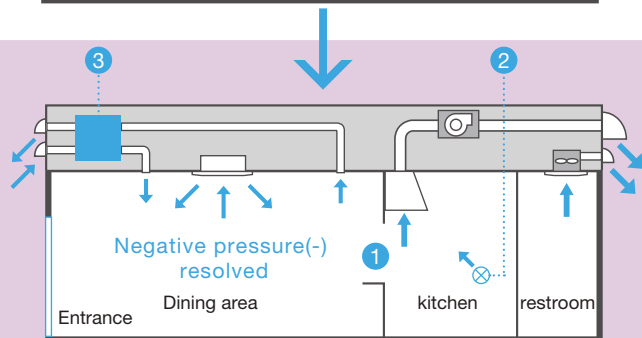

### Office & Shoplot

#### Problem

- Ventilation cannot be achieved by opening windows or doors.
- No large windows or doors at the area.

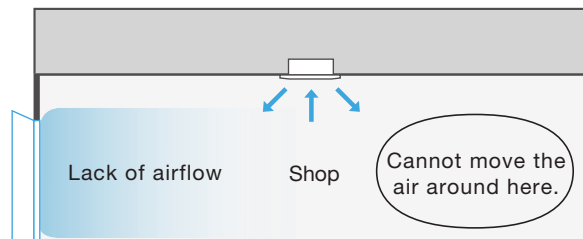

No air movement due to low airflow.

In the case of windows and doors are located at the front only, there will be no air movement at the back of the shop. Air will be stagnant and not well ventilated.

#### Countermeasure plan

Heat Reclaim Ventilator must be installed to provide effective mechanical ventilation.

As a result, airflow is able to ventilate all areas of the shop.

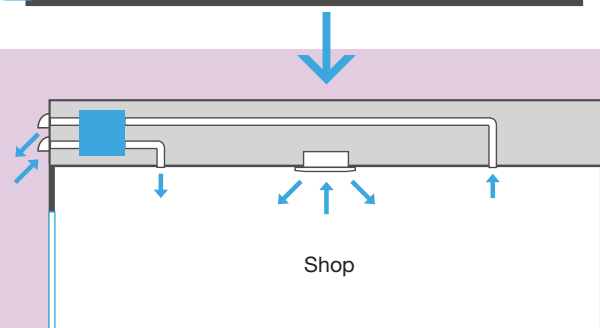



# AIR TREATMENT EQUIPMENT LINE-UP

## Remote Controller & Option List

**Standard remote controller:** - BRC1H62W/BRC1H62K

**Optional remote controller:** - Navigation remote controller-BRC1E63, Simplified remote controller-BRC2E61

(Optional controller are connectable with some function limitation.)

Function	Detail	BRC1H62W(K)	BRC1E63	BRC2E61
				
Air conditioner interlock	Interlock Heat Reclaim Ventilator with air conditioner by one remote controller.	●	●	●
Ventilation mode	Switch the ventilation mode (Automatic, Heat exchange, Bypass).	●	●	-
Ventilation airflow rate	When using CO <sub>2</sub> sensor, ventilation volume can be changed.	●	●	●
Fresh up indication	Indicates that fresh up operation is being carried out.	●	-	-
CO <sub>2</sub> indication	Indicates value of CO <sub>2</sub> sensor.	○	-	-
Outdoor temperature indication	Indicates outdoor air temperature (OA).	○	-	-
Night time free cooling indication	Show the night purge icon when is set.	○	-	-
24 hours ventilating indication	Show the icon when 24hrs operation is set.	○	-	-
Ventilating operation indication	Indicates that ventilating operation is being carried out even when night purge operation and 24 hour ventilating operation is being carried out.	●	●	-
Ventilating standby indication	Indicates that ventilating operation has been stopped temporarily during pre-cool / pre-heat control.	○	-	-
Sharing CO <sub>2</sub> data	Share the CO <sub>2</sub> data to submit from main unit within the group.	○	-	-

Additional functions: ● Installed functions ○ Additional Installation function

### Option List:

Type	Item	VAM250HVE	VAM500HVE	VAM650HVE
Additional Function	Silencer	-	KDDM24B100	
	Nominal Pipe	-	φ200	
	mm			
	High efficiency filter	KAF242J25M	KAF242J65M	
	Air filter for replacement	KAF241J25M	KAF241J65M	
	Flexible duct (1m)	K-FDS151E	K-FDS201E	
	Flexible duct (2m)	K-FDS152E	K-FDS202E	
	CO <sub>2</sub> sensor	BRYC24A25M	BRYC24A65M	
	Humidity sensor	BRYH241A100 (for RA) / BRYH242A100 (for OA)		
	PM2.5 filtration unit	BAF249A300	BAF249A500	-
	PM2.5 with activated carbon filtration unit	BAF249A300C	BAF249A500C	-
	Wired remote controller	BRC1H62W (White) / BRC1H62K (Black) / BRC1E63 / BRC2E61		
Controlling device	Centralised controlling device	Residential central remote controller	DCS303A51*1	
		Central remote controller	DCS302CA61	
		Unified ON/OFF controller	DCS301BA61	
		Schedule Timer	DST301BA61	
	PCB adaptor	Wiring adaptor for electrical appendices	KRP2A62	
		Installation box for adaptor	KRP1C18A90	
		For heater control kit	BRP4A50A	
	PCB adaptor for wiring	KRP1C18		

Type	Item	VAM800HVE	VAM1000HVE	VAM1500HVE	VAM2000HVE
Additional function	Silencer	KDDDM24B100		KDDDM24B100 x 2	
	Nominal pipe	φ250			
	mm				
	High efficiency filter	KAF242K100M		KAF242K100M x 2	
	Air filter for replacement	KAF241K100M		KAF241K100M x 2	
	Flexible duct (1m)	K-FDS251E			
	Flexible duct (2m)	K-FDS252E			
	CO <sub>2</sub> sensor	BRYC24A100M			
	Humidity sensor	BRYH241A100 (for RA) / BRYH242A100 (for OA)			
	PM2.5 filtration unit	BAF429A20A			
	PM2.5 with activated carbon filtration unit	BAF429A20AC			
	Wired remote controller	BRC1H62W (White) / BRC1H62K (Black) / BRC1E63 / BRC2E61			
Controlling device	Centralised controlling device	Residential central remote controller	DCS303A51*1		
		Central remote controller	DCS302CA61		
		Unified ON/OFF controller	DCS301BA61		
		Schedule Timer	DST301BA61		
	PCB adaptor	Wiring adaptor for electrical appendices	KRP2A62		
		Installation box for adaptor	KRP1C18A90		
		For heater control kit	BRP4A50A		
	PCB adaptor for wiring	KRP1C18			

\* 1 For residential only. When connect with a Heat Reclaim Ventilator (VAM), you can only switch the power ON/OFF. It cannot be used with other central control equipment.

# Air Treatment Equipment

## Airflow rate control with CO<sub>2</sub> sensor

The CO<sub>2</sub> sensor controls airflow rate so that it best matches the changes of CO<sub>2</sub> level in the room. This prevents energy losses from over-ventilation while maintaining indoor air quality with optional CO<sub>2</sub> sensor.

- Example of CO<sub>2</sub> sensor operation in an office room:

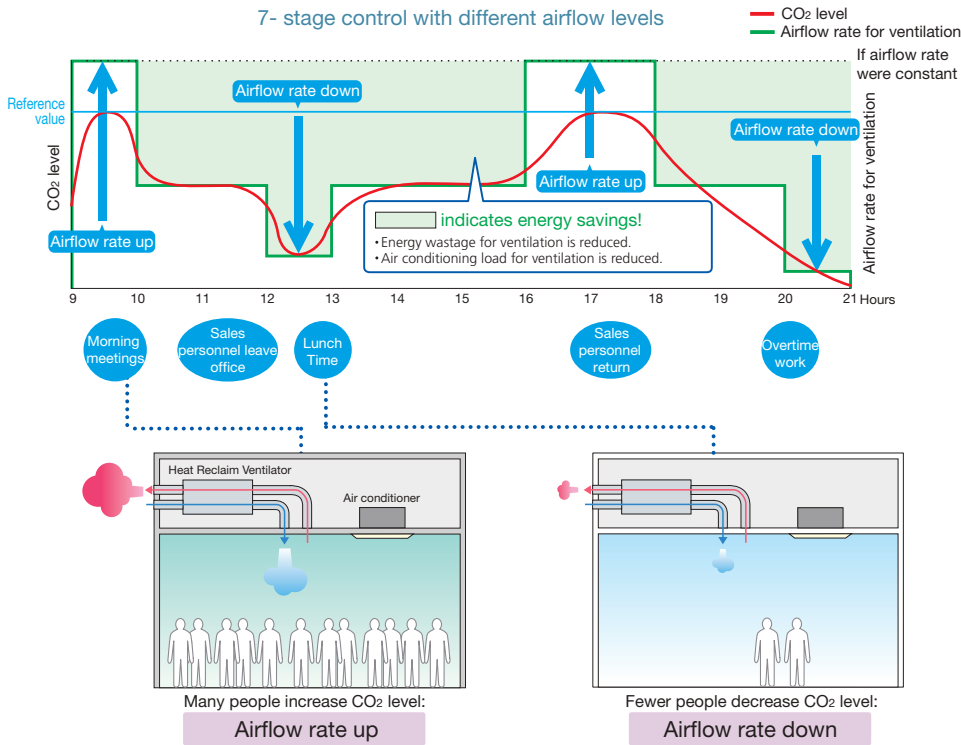

## Automatic Ventilation Mode Switching (Bypass control) with Humidity sensor

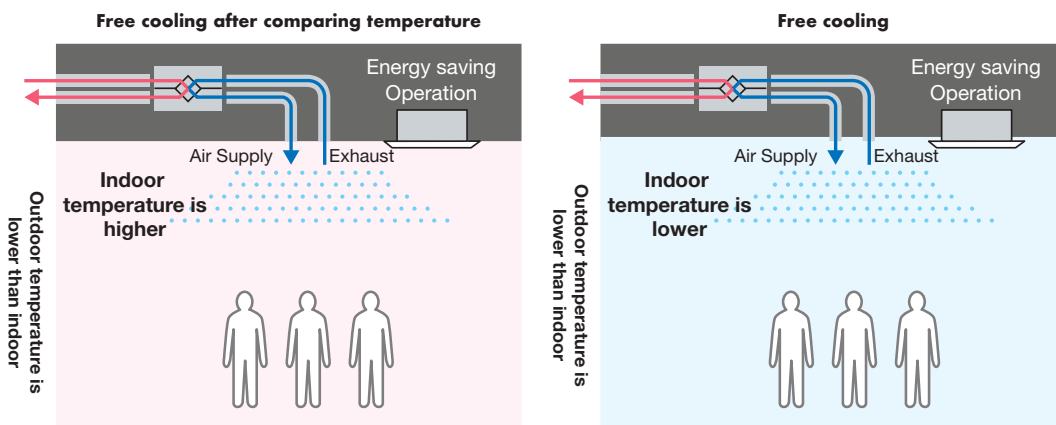

Suitable ventilation mode depending on condition will be switched automatically.

The ventilation unit detects room temperature and outside air temperature, then automatically switches to suitable ventilation mode to provide higher energy-savings. By installing humidity sensor (optional item), the mode will be switched automatically based on the amount of heat (energy) and discomfort index to further improve energy saving and comfort. \*1



\*1 "Energy saving ventilation mode" or "Comfortable ventilation mode" can be selected by local setting.

# TECHNICAL SPECIFICATIONS





Unit						
MODEL				VAM250HVE	VAM500HVE	VAM650HVE
Power Supply				1-phase, 220-240 V/220V, 50/60 Hz		
Temp. Exchange Efficiency (50/60 Hz)	For Cooling	Ultra-High	%	60.5 / 60.5	61.5 / 61.5	59.5 / 59.5
		High		60.5 / 60.5	61.5 / 61.5	59.5 / 59.5
		Low		65.0 / 65.5	63.0 / 64.0	62.5 / 63.0
	For Heating	Ultra-High	%	76.5 / 76.5	80.0 / 80.0	74.5 / 74.5
		High		76.5 / 76.5	80.0 / 80.0	74.5 / 74.5
		Low		78.5 / 79.0	81.5 / 82.5	76.5 / 77.0
Enthalpy Exchange Efficiency (50/60 Hz)	For Cooling	Ultra-High	%	60.0 / 60.0	62.5 / 62.5	60.0 / 60.0
		High		60.0 / 60.0	62.5 / 62.5	60.0 / 60.0
		Low		61.5 / 62.0	64.0 / 65.0	62.5 / 63.0
	For Heating	Ultra-High	%	69.5 / 69.5	71.0 / 71.0	68.0 / 68.0
		High		69.5 / 69.5	71.0 / 71.0	68.0 / 68.0
		Low		73.0 / 73.5	72.5 / 73.5	69.5 / 71.5
Power Consumption (50/60 Hz)	Heat Exchange Mode	Ultra-High	W	126-141 / 172	296-326 / 390	381-426 / 472
		High		114-123 / 144	248-261 / 329	307-319 / 413
		Low		75-83 / 79	223-233 / 268	264-276 / 332
	Bypass Mode	Ultra-High	W	126-141 / 172	296-326 / 390	381-426 / 472
		High		114-123 / 144	248-261 / 329	307-319 / 413
		Low		75-83 / 79	223-233 / 268	264-276 / 332
Sound Level (50/60 Hz)	Heat Exchange Mode	Ultra-High	dBA	33.0-34.0 / 33.5	36.0-37.0 / 38.5	37.5-38.0 / 38.0
		High		31.0-32.5 / 28.0	35.0-36.0 / 35.0	36.0-36.5 / 37.0
		Low		23.0-25.5 / 21.0	32.0-34.0 / 31.0	34.0-35.0 / 32.5
	Bypass Mode	Ultra-High	dBA	33.0-34.0 / 34.5	36.0-37.0 / 38.5	39.5-40.0 / 42.0
		High		31.5-32.5 / 29.0	35.0-36.0 / 35.0	38.0-38.5 / 39.0
		Low		23.5-25.5 / 21.5	32.0-34.0 / 31.0	35.5-36.5 / 33.5
Casing				Galvanised steel plate		
Insulation Material				Self-extinguishable polyurethane foam		
Dimensions (HxWxD)			mm	278 x 551 x 810	338 x 832 x 973	
Machine Weight			kg	22	41	43
Heat Exchange System				Air to air cross flow total heat (Sensible heat + latent heat) exchange		
Heat Exchange Element Material				Specially processed nonflammable paper		
Air Filter				Multidirectional fibrous fleeces		
Fan	Type			Sirocco fan		
	Airflow Rate (50/60 Hz)	Ultra- High	m³/h	250 / 250	500 / 500	650 / 650
		High		250 / 250	500 / 500	650 / 650
		Low		165 / 145	470 / 420	570 / 495
	External Static Pressure (50/60 Hz)	Ultra- High	Pa	115-130 / 135	165-190 / 245	185-190 / 260
		High		80-90 / 60	140-175 / 180	140-155 / 210
		Low		35-75 / 20	124-155 / 127	108-119 / 122
Motor Output			kW	0.030 x 2	0.100 x 2	0.170 x 2
Net Supply Airflow Ratio		Ultra-High	%	90		
Connection Duct Diameter		Indoor side	mm	φ150	φ200	φ200
		Outdoor side	mm			
Unit Ambient Condition				-15°C~50°C DB, 80%RH or less		

\* Values for electrical current, power consumption, and efficiency are at the above above-stated airflow.

\* Exchange efficiencies are values based on performance codes and air conditions that comply with JIS B8628:2017.

\* Temperature exchange efficiency and enthalpy exchange efficiency vary according to the ratio of supply air and exhaust air and air conditions.

\* Operation sound is an anechoic chamber conversion that complies with JISB8628:2017. When measured under actual installation conditions, the operation sound is usually greater due to ambient noise and reverberation.

Unit						
Model			VAM800HVE	VAM1000HVE	VAM1500HVE	VAM2000HVE
Power Supply			1-phase, 220-240 V / 220 V, 50/60 Hz			
Temp. Exchange Efficiency (50/60 Hz)	For Cooling	Ultra-High	61.5 / 61.5	58.0 / 58.0	61.5 / 61.5	58.5 / 58.5
		High	61.5 / 61.5	58.0 / 58.0	61.5 / 61.5	58.5 / 58.5
		Low	64.0 / 65.0	61.5 / 62.0	65.5 / 66.0	65.5 / 65.5
	For Heating	Ultra-High	77.5 / 77.5	74.0 / 74.0	77.5 / 77.5	73.5 / 73.5
		High	77.5 / 77.5	74.0 / 74.0	77.5 / 77.5	73.5 / 73.5
		Low	78.5 / 79.5	76.0 / 76.5	79.5 / 80.0	76.5 / 77.0
Enthalpy Exchange Efficiency (50/60 Hz)	For Cooling	Ultra-High	63.0 / 63.0	60.0 / 60.0	63.0 / 63.0	60.0 / 60.0
		High	63.0 / 63.0	60.0 / 60.0	63.0 / 63.0	60.0 / 60.0
		Low	64.5 / 65.5	62.0 / 62.5	65.5 / 66.0	64.5 / 64.5
	For Heating	Ultra-High	72.0 / 72.0	68.5 / 68.5	72.0 / 72.0	68.0 / 68.0
		High	72.0 / 72.0	68.5 / 68.5	72.0 / 72.0	68.0 / 68.0
		Low	74.0 / 75.0	72.0 / 72.5	74.0 / 75.0	71.0 / 71.5
Power Consumption (50/60 Hz)	Heat Exchange Mode	Ultra-High	644-684 / 829	683-736 / 883	1,274-1,353 / 1,645	1,365-1,471 / 1,763
		High	603-612 / 712	621-656 / 763	1,207-1,225 / 1,423	1,241-1,311 / 1,526
		Low	504-544 / 562	539-569 / 594	1,008-1,089 / 1,125	1,079-1,138 / 1,188
	Bypass Mode	Ultra-High	644-684 / 829	683-736 / 883	1,274-1,353 / 1,645	1,365-1,471 / 1,763
		High	603-612 / 712	621-656 / 763	1,207-1,225 / 1,423	1,241-1,311 / 1,526
		Low	504-544 / 562	539-569 / 594	1,008-1,089 / 1,125	1,079-1,138 / 1,188
Sound Level (50/60 Hz)	Heat Exchange Mode	Ultra-High	41.5-42.5 / 41.0	42.0-43.0 / 42.5	43.0-44.0 / 44.0	43.5-44.0 / 44.5
		High	39.5-41.0 / 37.0	40.0-41.0 / 38.0	41.0-42.5 / 39.0	41.5-43.0 / 40.0
		Low	36.0-38.5 / 33.0	38.0-39.5 / 34.5	38.0-40.5 / 35.0	39.0-41.0 / 36.5
	Bypass Mode	Ultra-High	41.5-42.5 / 41.0	42.0-43.0 / 42.5	43.0-44.0 / 44.0	43.5-44.0 / 44.5
		High	39.5-41.0 / 37.0	40.0-41.0 / 38.0	41.0-42.5 / 39.0	41.5-43.0 / 40.0
		Low	36.0-38.5 / 33.0	38.0-39.5 / 34.5	38.0-40.5 / 35.0	39.0-41.0 / 36.5
Casing			Galvanised steel plate			
Insulation Material			Self-extinguishable polyurethane foam			
Dimensions (H x W x D)		mm	387 x 1,012 x 1,110			785 x 1,012 x 1,110
Machine Weight		kg	63	63	138	138
Heat Exchange System			Air to air cross flow total heat (Sensible heat + latent heat) exchange			
Heat Exchange Element Material			Specially processed nonflammable paper			
Air Filter			Multidirectional fibrous fleeces			
Fan	Type		Sirocco fan			
	Airflow Rate (50/60 Hz)	Ultra-High	800 / 800	1,000 / 1,000	1,500 / 1,500	2,000 / 2,000
		High	800 / 800	1,000 / 1,000	1,500 / 1,500	2,000 / 2,000
		Low	720 / 610	880 / 835	1,350 / 1,250	1,650 / 1,580
	External Static Pressure (50/60 Hz)	Ultra-High	210-235 / 250	205-225 / 220	195-215 / 235	190-210 / 210
		High	170-215 / 140	155-195 / 100	150-180 / 125	140-180 / 85
Low		138-174 / 81	115-150 / 70	123-146 / 88	96-123 / 53	
Motor Output		kW	0.190 x 2		0.190 x 4	
Net Supply Airflow Ratio		Ultra-High	%	90	90	90
Connection Duct Diameter		Indoor side	mm	φ250	φ250	φ250 × 4
		Outdoor side	mm	φ250	φ250	□ (680 × 290) × 2
Unit Ambient Condition			-15°C-50°C DB, 80%RH or less			

\* Values for electrical current, power consumption, and efficiency are at the above above-stated airflow.  
 \* Exchange efficiencies are values based on performance codes and air conditions that comply with JIS B8628:2017.  
 \* Temperature exchange efficiency and enthalpy exchange efficiency vary according to the ratio of supply air and exhaust air and air conditions.  
 \* Operation sound is an anechoic chamber conversion that complies with JISB8628:2017. When measured under actual installation conditions, the operation sound is usually greater due to ambient noise and reverberation.

## Note:

- Ask an authorised Daikin dealer to install Daikin products. Do not try to install the product yourself or get it installed by any unauthorised dealer. Improper installation can result in water or refrigerant leakage, electrical shock, fire or explosion. Warranty of the product shall be void if not installed by an authorised Daikin dealer.
- Use only those parts and accessories supplied or specified by Daikin. Ask authorised Daikin dealer for any repair or component. Warranty of the product / component shall be void if non-specified spares are used or repaired by a non Daikin dealer.
- Please ensure to install ELCB (Earth Leakage Circuit Breaker) for outdoor units to prevent ground fault effects.
- Read the user's manual carefully before using the product. The user's manual provides important safety instructions and warnings. Be sure to follow these instructions and warnings.

For any enquiry, either call the numbers mentioned below or contact your nearest Daikin dealer.

### Cautions on product corrosion

1. Air conditioners should not be installed in areas where corrosive gases, such as acid gas or alkaline gas, are produced.
2. If the outdoor unit is to be installed close to the sea shore, direct exposure to the sea breeze should be avoided. If you need to install the outdoor unit close to the sea shore, contact your local distributor.



JMI-0107



JQA-1452

#### About ISO 9001

ISO 9001 is a plant certification system defined by the International Organization for Standardization (ISO) relating to quality assurance. ISO 9001 certification covers quality assurance aspects related to the "design, development, manufacture, installation, and supplementary service" of products manufactured at the plant.



EC99J2044

#### About ISO 14001

ISO 14001 is the standard defined by the International Organization for Standardization (ISO) relating to environmental management systems. Our group has been acknowledged by an internationally accredited compliance organisation as having an appropriate programme of environmental protection procedures and activities to meet the requirements of ISO 14001.

## DAIKIN AIRCONDITIONING INDIA PVT. LTD.

12<sup>th</sup> Floor, Building No. 9, Tower A, DLF Cyber City, DLF Phase III, Gurgaon - 122 002, Haryana, India.  
Tel.: 0124-4555444, Fax.: 0124-4555333



#### CUSTOMER CONTACT CENTRE:

011-40319300, 1860-180-3900  
customerservice@daikanindia.com

## SALES & SERVICE OFFICES

Ahmedabad-Tel: 079-40013100  
Bengaluru-Tel: 080-25722336/25722337  
Bhubaneshwar-Tel: 0674-2554677  
Chandigarh-Tel: 0172-4947200/30  
Chennai-Tel: 044-40807676  
Cochin-Tel: 0484-4038646  
Delhi-Tel: 011-43834400/5500  
Ghaziabad-Tel: 0120-4205851  
Indore-Tel: 0731-4005864  
Jaipur-Tel: 0141-2218903/04/05/06

Kolkata-Tel: 033-40608019/40659544  
Lucknow-Tel: 0522-4309858/59/60  
Ludhiana-Tel: 0161-5077028/29/30  
Mumbai-Tel: 022-62321666  
Patna-Tel: 0612-2582282  
Pune-Tel: 020-25560300  
Raipur-Tel: 0771-4911225  
Ranchi-Mob: 7008704566  
Secunderabad-Tel: 040-49134283  
Vijayawada-Tel: 0866-2952226/24/25

To know more, give a missed call or SMS:

<DAIKIN> to 9210188999

Visit us at: [www.daikinindia.com](http://www.daikinindia.com)

Follow us on:

- [www.facebook.com/daikinindia](http://www.facebook.com/daikinindia)
- [www.twitter.com/daikinindia](http://www.twitter.com/daikinindia)
- [www.instagram.com/daikinindia](http://www.instagram.com/daikinindia)
- [in.company/daikin-airconditioning-india-pvt.-ltd](http://in.company/daikin-airconditioning-india-pvt.-ltd)
- [www.youtube.com/user/DaikinACIndia](http://www.youtube.com/user/DaikinACIndia)

For more product information:



For More information  
'Scan Me'

- The specifications, designs, and information in this brochure are subject to change without notice.