

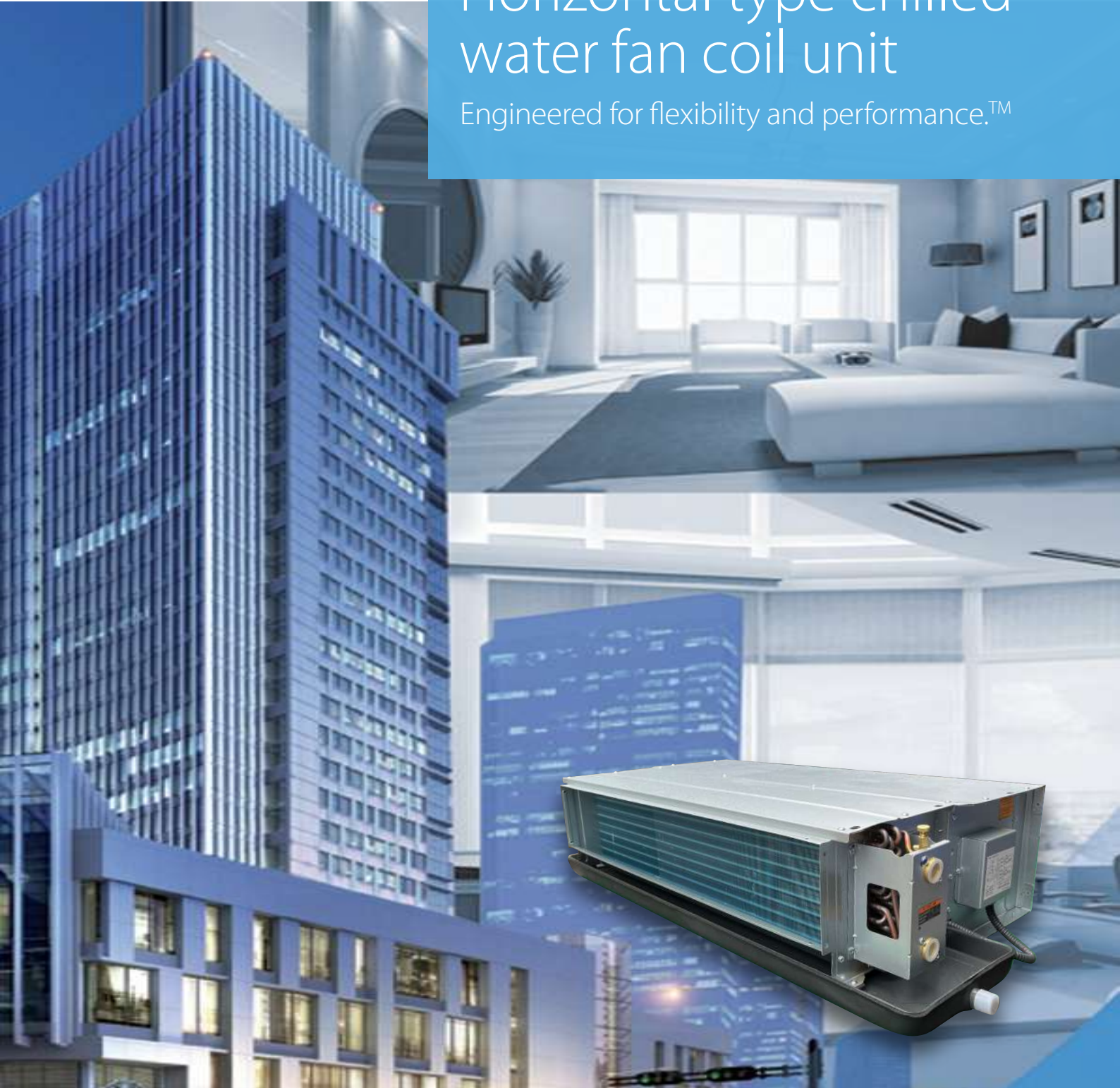

# Horizontal type chilled water fan coil unit

Engineered for flexibility and performance.™



FWW-V Series  
FWW-T Series

FWW-AA Series  
FUW-A Series

# CONTENTS

FWW-V Horizontal Ceiling Concealed Fan Coil Unit ..... 04	FUW-A Ultra-thin ceiling unit for High ESP application .... 21
FWW-T Ceiling Concealed Fan Coil Unit ..... 11	Wiring ..... 26
FWW-AA Ceiling Exposed Fan Coil Unit ..... 17	

## Introduction

For years, DAIKIN has been providing the society with multiple types of high quality air handling systems and has made remarkable achievements in related fields. Integrating the advanced air conditioner manufacturing technology and process of DAIKIN, DAIKIN fan coil units showcase more compact structure, more convenient installation and maintenance, more efficient performance and lower noises, and have been widely used in public buildings, hospitals, office buildings, hotels, high-end residences, etc.



Galaxy SOHO (Beijing)





Palm Jumeirah (Dubai, UAE)



White Swan Hotel (Guangzhou)

In this community, DAIKIN is renowned for its complete product series, covering the full range of air-conditioning, purifying and refrigeration equipment. More importantly, DAIKIN boasts the most complete fan coil series and realizes product experience covering units, valves and controls. It is easier to use for customers.

Installation type	Outlook	Series	3 Rows	4 Rows	4 rows District cooling	3+1 Rows	6 Rows	Application type	
Ceiling concealed unit		FWW-VC	√					Compact size, wide application	
		FWW-VF		√					
		FWW-VA			√				
		FWW-VH					√		High air flow can be applied for narrow installation.
		FWW-TC	√						
		FWW-TF		√					
FWW-TA				√					
Ceiling exposed unit		FWW-AA			√			Exposed type	
High ESP Ceiling unit		FUW-A		√			√	Large air flow and high ESP	

\* We are always improving our products to make them better. Therefore all specifications and details are subject to change without prior notice. Please contact with the sales to check if this is the latest catalogue.

# Features

## ► Centrifugal impeller

The double inlet double width(DWDI) centrifugal fan featuring high-efficiency wide-impeller and multi-blade forward-curved is adopted to implement low speed, large air flow and low noise.



## ► High-efficiency motor

High efficiency and energy saving, powerful, stable and quiet operation; configuration of the international brand NSK bearing, ensuring efficient, safe and maintenance-free operation.



## ► Plastic-coated metal hose

The cable protection pipe for the motor uses plastic-coated metal hose; the plastic-coated metal hose is light in weight and well flexible, with outstanding barrier property; The hose is resistant to corrosion, wear and high temperature; it has good insulation property and can better protect safety in use.



## ► Smart control (option)

Several types of thermostats options are offered to comply with 2-pipe and 4-pipe system, they are widely used for industrial, commercial and residential buildings, please refer to thermostat's catalog for detailed information.

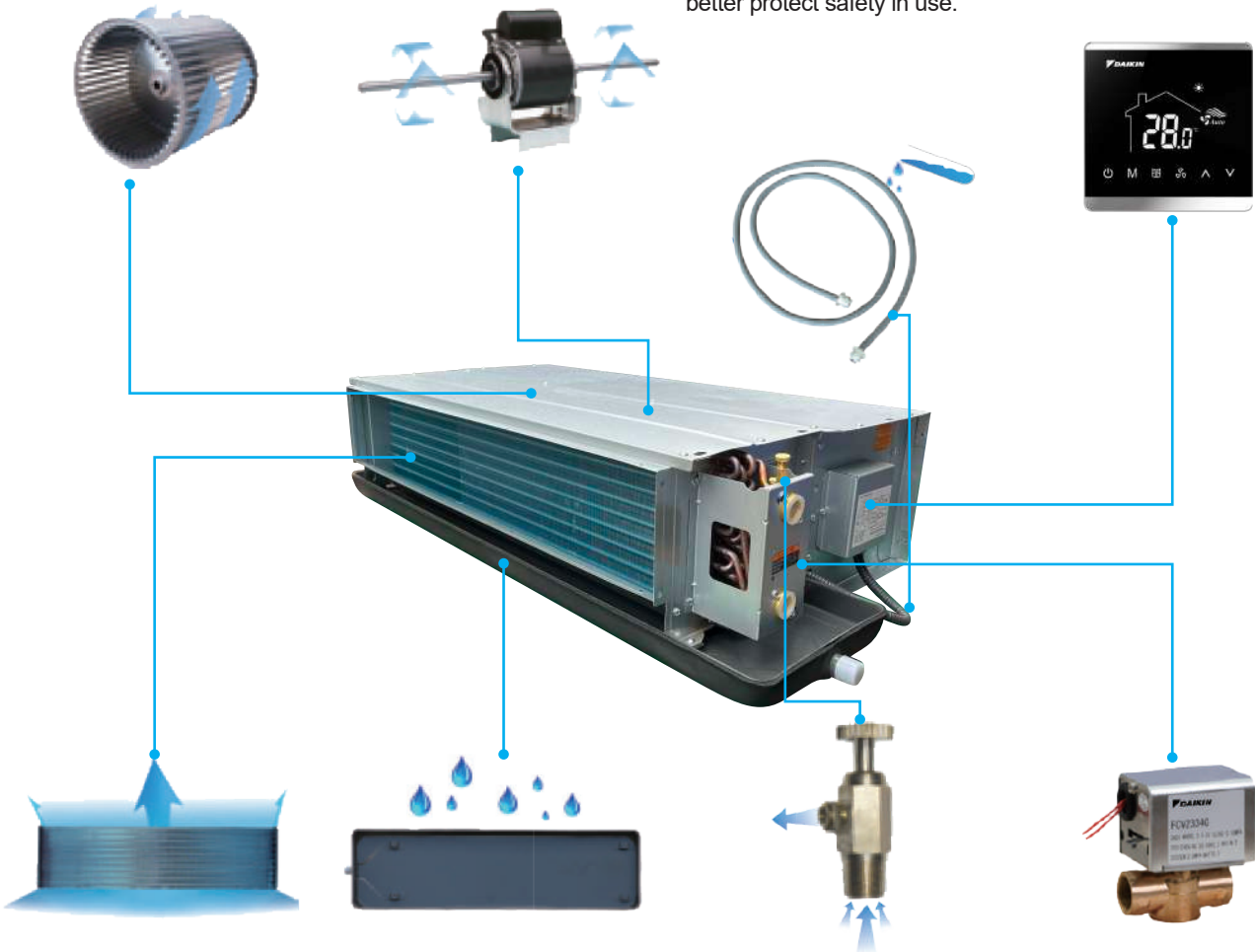

## ► High-efficiency heat exchanger

Formed using high quality copper tubes and highly efficient hydrophilic aluminum fins through mechanical expansion joint to reduce heat resistance; Quasi counterflow fan coil design enables thorough heat exchange between air and water to guarantee high efficiency in heat exchange.

## ► New self-slope drain pan

The self-slope structure design ensures quick drainage of condensate water; with spray on both sides for anti-corrosion, the tray surface is cleaner; the integrated design is adopted to avoid cold bridges.



## ► Manual air vent valve

The unit is configured with manual air vent valve for convenient operation, quicker discharge, and easier installation. The valve is placed at the highest point to guarantee thorough discharging of air in the system and ensure the heat exchange effect.

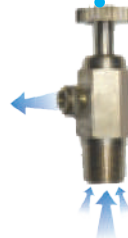

## ► 2-way/3-way valves (option)

FCV series 2-way/3-way valve including electric actuator can be provided as an option. The actuator takes small space which can be installed closed to the wall. It is reliable with high quality and super low noise.



# FWW-V Horizontal Ceiling Concealed Fan Coil Unit

Our FWW-V series fan coil adopts efficient heat exchange design and standardized production process. With the advanced motor control technology, the precise operation of the fan coil unit is guaranteed. All components of the unit are subject to selection of quality material and strict inspection to provide intelligent control products and centralized control solutions. The unit widely applies to all kinds of public, commercial and civil buildings.



### ► Ingenious and thin body

The unit, light, shapely, thin and compact, can be even mounted in a narrow ceiling, occupying less mounting space. With a hidden design, the unit can match with a variety of decoration modes and perfectly fix to different architecture styles.



### ► Quiet operation, comfort and enjoyment

The unit is equipped with a low-noise, wide-impeller, and low-speed fan. Moreover, each fan is checked and inspected before delivery. The interior of the fan is adhered with efficient damping and heat insulating material to ensure quiet and efficient operation of the unit.

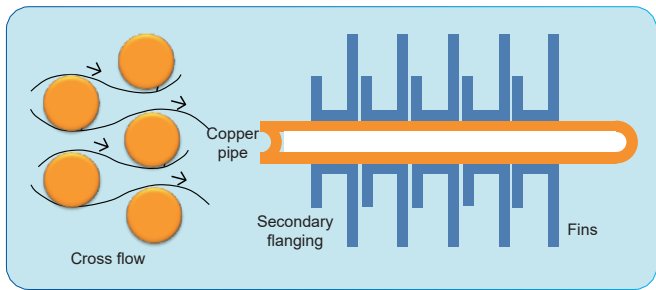

### ► Efficient heat exchange and excellent performance

By covering quality copper pipes with hyperbolic louver type hydrophilic aluminum fins and combining a quasi-counter flow design, the unit has great performance in heat exchange. The wide-impeller design lowers the noise of the unit.



### ► Abundant configuration, safety and reliability

The unit may be equipped with a lift pump, a PTC electric heater, an air purification component, or other devices to meet a variety of function requirements, and be assisted by an intelligent control mode, thus being flexible and safe.

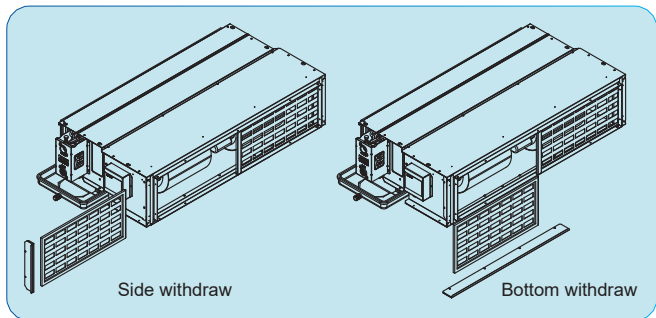

### ► Easy maintenance

With unique design, the filter can be withdraw from either bottom or side. Users can clean or replace the filter much easier.



### ► Authoritative certificate

For the whole series, we comply with AHRI 400 Standard. For district cooling unit, Eurovent certificate is granted.

## Nomenclature

1	2	3	4	5	6	7	8	9	10	11	12	13	14	15	16	17	18
F	W	W	1	0	0	0	V	A	N	R	E	F	-	A	0	A	E

- ▶ Sales region: E: for export
- ▶ Power supply:  
A- 220-240V/1 Ph/50Hz  
K- 208-230V/1 Ph/60Hz
- ▶ E-heater power: 0-None    1-1kW    2-2kW    .....
- ▶ Drain pan:  
A-Standard drain pan  
E-SUS drain pan  
C-Extended drain pan  
G-Extended SUS drian pan
- ▶ Motor type: "-"-AC motor
- ▶ Filter:  
F-8mm nylon filer  
H-25mm AL filter  
G-25mm G4 filter
- ▶ Return air plenum:  
C-None  
E-Back type (5mmXPE)  
F-Back type (15mmPF)
- ▶ Pipe orientation: (Facing to the air flow)  
L-Left  
R-Right
- ▶ Rated ESP code: 50Pa
- ▶ Coil type:  
C-3rows  
F-4rows  
H-3rows+1row  
A-4rows (District cooling)
- ▶ Series: V-V series
- ▶ Unit model: 200    300    400.....1400 CFM
- ▶ Horizontal type cealing concealed FCU

# FWW-V Horizontal Ceiling Concealed Fan Coil Unit

## Standard Unit / 2-Pipe / 3 Rows

		Model	FWW200VC	FWW300VC	FWW400VC	FWW500VC	FWW600VC	FWW700VC	FWW800VC	FWW1000VC	FWW1200VC	FWW1400VC
Air Flow	High	m <sup>3</sup> /h	340	510	640	850	960	1170	1360	1680	1900	2180
		CFM	200	300	376	500	565	688	800	988	1118	1282
	Medium	m <sup>3</sup> /h	320	470	600	800	920	1100	1300	1620	1870	2030
		CFM	188	276	353	471	541	647	765	953	1100	1194
	Low	m <sup>3</sup> /h	280	380	450	600	730	730	950	1100	1360	1400
		CFM	165	224	265	353	429	429	559	647	800	824
ESP	Medium	Pa	50									
		in.wg.	0.2									
Total Cooling Capacity	W	2000	3100	3800	4900	5600	6500	8000	9000	10300	11500	
	Btu/h	6824	10577	12966	16719	19107	22178	27296	30708	35144	39238	
Water Flow Rate	m <sup>3</sup> /h	0.34	0.53	0.65	0.84	0.96	1.11	1.37	1.54	1.77	1.97	
	USGPM	1.50	2.33	2.86	3.70	4.22	4.88	6.03	6.78	7.79	8.67	
Water Pressure drop	kPa	16	18	18	26	22	33	35	38	27	39	
	in.wg.	64	72	72	104	88	133	141	153	108	157	
Rated Power Input	High	W	49	68	81	103	122	163	172	238	280	315
	Medium	W	46	65	77	98	115	156	165	225	265	295
	Low	W	42	57	71	92	107	130	150	202	243	260
Rated Running Current	High	A	0.22	0.3	0.36	0.45	0.54	0.72	0.76	1.05	1.23	1.38
	Medium	A	0.2	0.29	0.34	0.43	0.51	0.69	0.73	1	1.18	1.31
	Low	A	0.19	0.26	0.32	0.42	0.49	0.59	0.69	0.92	1.11	1.19
Sound Pressure Level	High	dB(A)	39	39	41	43	44	47	44	47	49	49.5
	Medium	dB(A)	38	38	40	42	43	46	43	46	48	48.5
	Low	dB(A)	34.5	32	35	35.5	39	37	37	37.5	41	41
Filter	Type	8mm Nylon Filter										
	Access	Both Side & Bottom Withdraw										
Coil	Row No.	3										
	Working Pressure	2.0 MPa										
	Material	Copper tube & Hydrophilic Aluminum										
	Water Volume	L	0.48	0.68	0.74	0.83	0.93	0.99	1.35	1.4	1.62	1.79
Fan	Type	Galvanized Steel Centrifugal Fan (Forward)										
	Quantity	1	2	2	2	2	2	3	3	4	4	
Motor	Type	3 Speed PSC Motor										
	Quantity	1	1	1	1	1	1	2	2	2	2	
	IP/Insulation	IP20 / ≥B										

### NOTES:

- 1) All performance is tested under 230V~/50Hz and unit couple with return air plenum and 8mm nylon filter.
- 2) The air flow, power input, sound data is tested on standard air condition without water in coil.
- 3) The capacity is tested under M speed, 50Pa and below condition:  
---Cooling capacity: Entering air DB/WB: 27°C/19.5°C, water inlet 7°C, water outlet 12°C
- 4) The sound pressure is measured according to GB/T 19232-2019 (1m below the unit bottom).

# FWW-V Horizontal Ceiling Concealed Fan Coil Unit

## Standard Unit / 2-Pipe / 4 Rows

		Model	FWW200VF	FWW300VF	FWW400VF	FWW500VF	FWW600VF	FWW700VF	FWW800VF	FWW1000VF	FWW1200VF	FWW1400VF
Air Flow	High	m <sup>3</sup> /h	340	510	640	850	960	1170	1360	1680	1900	2180
		CFM	200	300	376	500	565	688	800	988	1118	1282
	Medium	m <sup>3</sup> /h	320	470	600	800	920	1100	1300	1620	1870	2030
		CFM	188	276	353	471	541	647	765	953	1100	1194
	Low	m <sup>3</sup> /h	280	380	450	600	730	730	950	1100	1360	1400
		CFM	165	224	265	353	429	429	559	647	800	824
ESP	Medium	Pa	50									
		in.wg.	0.2									
Total Cooling Capacity		W	2500	3600	4300	5100	6200	7100	8900	10500	11100	12200
		Btu/h	8530	12283	14672	17401	21154	24225	30367	35826	37873	41626
Water Flow Rate		m <sup>3</sup> /h	0.43	0.62	0.74	0.87	1.06	1.22	1.53	1.8	1.9	2.09
		USGPM	1.89	2.73	3.26	3.83	4.66	5.37	6.73	7.92	8.36	9.20
Water Pressure drop		kPa	30	34	29	24	38	36	32	39	38	38
		in.wg.	120	137	116	96	153	145	129	157	153	153
Rated Power Input	High	W	49	68	81	103	122	163	172	238	280	315
	Medium	W	46	65	77	98	115	156	165	225	265	295
	Low	W	42	57	71	92	107	130	150	202	243	260
Rated Running Current	High	A	0.22	0.3	0.36	0.45	0.54	0.72	0.76	1.05	1.23	1.38
	Medium	A	0.2	0.29	0.34	0.43	0.51	0.69	0.73	1	1.18	1.31
	Low	A	0.19	0.26	0.32	0.42	0.49	0.59	0.69	0.92	1.11	1.19
Sound Pressure Level	High	dB(A)	39	39	41	43	44	47	44	47	49	49.5
	Medium	dB(A)	38	38	40	42	43	46	43	46	48	48.5
	Low	dB(A)	34.5	32	35	35.5	39	37	37	37.5	41	41
Filter	Type	8mm Nylon Filter										
	Access	Both Side & Bottom Withdraw										
Coil	Row No.	4										
	Working Pressure	2.0 MPa										
	Material	Copper tube & Hydrophilic Aluminum										
	Water Volume	L	0.64	0.91	0.98	1.1	1.25	1.32	1.8	1.87	2.16	2.38
Fan	Type	Galvanized Steel Centrifugal Fan (Forward)										
	Quantity		1	2	2	2	2	2	3	3	4	4
Motor	Type	3 Speed PSC Motor										
	Quantity		1	1	1	1	1	1	2	2	2	2
	IP/Insulation	IP20 / ≥B										

### NOTES:

- 1) All performance is tested under 230V~/50Hz and unit couple with return air plenum and 8mm nylon filter.
- 2) The air flow, power input, sound data is tested on standard air condition without water in coil.
- 3) The capacity is tested under M speed, 50Pa and below condition:  
---Cooling capacity: Entering air DB/WB: 27°C/19.5°C, water inlet 7°C, water outlet 12°C
- 4) The sound pressure is measured according to GB/T 19232-2019 (1m below the unit bottom).

# FWW-V Horizontal Ceiling Concealed Fan Coil Unit

## Standard Unit / 4-Pipe / 3+1 Rows

		Model	FWW200VH	FWW300VH	FWW400VH	FWW500VH	FWW600VH	FWW700VH	FWW800VH	FWW1000VH	FWW1200VH	FWW1400VH
Air Flow	High	m <sup>3</sup> /h	340	510	640	850	960	1170	1360	1680	1900	2180
		CFM	200	300	376	500	565	688	800	988	1118	1282
	Medium	m <sup>3</sup> /h	320	470	600	800	920	1100	1300	1620	1870	2030
		CFM	188	276	353	471	541	647	765	953	1100	1194
	Low	m <sup>3</sup> /h	280	380	450	600	730	730	950	1100	1360	1400
		CFM	165	224	265	353	429	429	559	647	800	824
ESP	Medium	Pa	50									
		in.wg.	0.2									
Total Cooling Capacity	W	1960	3140	3690	4910	5480	6400	7850	8930	9990	11030	
	Btu/h	6688	10714	12590	16753	18698	21837	26784	30469	34086	37634	
Cooling Water Flow Rate	m <sup>3</sup> /h	0.34	0.54	0.63	0.84	0.94	1.1	1.35	1.53	1.71	1.89	
	USGPM	1.50	2.38	2.77	3.70	4.14	4.84	5.94	6.73	7.52	8.32	
Cooling Water Pressure drop	kPa	18	25	18	31	25	33	32	40	28	35	
	in.wg.	72	100	72	124	100	133	129	161	112	141	
Nominal Heating Capacity	W	1910	2850	3420	4420	4390	5680	6900	7920	8880	9470	
	Btu/h	6517	9724	11669	15081	14979	19380	23543	27023	30299	32312	
Heating Water Flow Rate	m <sup>3</sup> /h	0.16	0.24	0.29	0.38	0.38	0.49	0.59	0.68	0.76	0.81	
	USGPM	0.70	1.06	1.28	1.67	1.67	2.16	2.60	2.99	3.34	3.56	
Heating Water Pressure drop	kPa	27	12	18	28	29	18	29	34	22	27	
	in.wg.	108	48	72	112	116	72	116	137	88	108	
Rated Power Input	High	W	49	68	81	103	122	163	172	238	280	315
	Medium	W	46	65	77	98	115	156	165	225	265	295
	Low	W	42	57	71	92	107	130	150	202	243	260
Rated Running Current	High	A	0.22	0.3	0.36	0.45	0.54	0.72	0.76	1.05	1.23	1.38
	Medium	A	0.2	0.29	0.34	0.43	0.51	0.69	0.73	1	1.18	1.31
	Low	A	0.19	0.26	0.32	0.42	0.49	0.59	0.69	0.92	1.11	1.19
Sound Pressure Level	High	dB(A)	39	39	41	43	44	47	44	47	49	49.5
	Medium	dB(A)	38	38	40	42	43	46	43	46	48	48.5
	Low	dB(A)	34.5	32	35	35.5	39	37	37	37.5	41	41
Filter	Type	8mm Nylon Filter										
	Access	Both Side & Bottom Withdraw										
Coil	Row No.-Cooling	3										
	Row No.-Heating	1										
	Working Pressure	2.0 MPa										
	Material	Copper tube & Hydrophilic Aluminum										
	Water Volume-Cooling	L	0.48	0.68	0.74	0.83	0.93	0.99	1.35	1.4	1.62	1.79
	Water Volume-Heating	L	0.16	0.23	0.25	0.28	0.31	0.33	0.45	0.47	0.54	0.6
Fan	Type	Galvanized Steel Centrifugal Fan (Forward)										
	Quantity	1	2	2	2	2	2	3	3	4	4	
Motor	Type	3 Speed PSC Motor										
	Quantity	1	1	1	1	1	1	2	2	2	2	
	IP/Insulation	IP20 / ≥B										

### NOTES:

- 1) All performance is tested under 230V~/50Hz and unit couple with return air plenum and 8mm nylon filter.
- 2) The air flow, power input, sound data is tested on standard air condition without water in coil.
- 3) The capacity is tested under M speed, 50Pa and below condition:
  - Cooling capacity: Entering air DB/WB: 27°C/19.5°C, water inlet 7°C, water outlet 12°C
  - Heating capacity: Entering air DB: 21°C, water inlet 60°C, water outlet 50°C
- 4) The sound pressure is measured according to GB/T 19232-2019 (1m below the unit bottom).

# FWW-V Horizontal Ceiling Concealed Fan Coil Unit

## District Cooling Unit / 2-Pipe / 4 Rows



		Model	FWW200VA	FWW300VA	FWW400VA	FWW500VA	FWW600VA	FWW700VA	FWW800VA	FWW1000VA	FWW1200VA	FWW1400VA
Air Flow	High	m <sup>3</sup> /h	340	510	640	850	960	1170	1360	1680	1900	2180
		CFM	200	300	376	500	565	688	800	988	1118	1282
	Medium	m <sup>3</sup> /h	320	470	600	800	920	1100	1300	1620	1870	2030
		CFM	188	276	353	471	541	647	765	953	1100	1194
	Low	m <sup>3</sup> /h	280	380	450	600	730	730	950	1100	1360	1400
		CFM	165	224	265	353	429	429	559	647	800	824
ESP	Medium	Pa	50									
		in.wg.	0.2									
Total Cooling Capacity	W	1800	2600	3200	3900	4700	5400	6400	7700	8800	10200	
	Btu/h	8871	10918	13307	16036	18425	21837	26272	30026	34802	34802	
Water Flow Rate	m <sup>3</sup> /h	0.17	0.25	0.3	0.37	0.45	0.51	0.61	0.73	0.84	0.97	
	USGPM	1.10	1.32	1.63	1.98	2.24	2.68	3.21	3.70	4.27	4.27	
Water Pressure drop	kPa	19	14	22	16	24	30	18	26	25	35	
	in.wg.	56	88	64	96	120	72	104	100	141	141	
Rated Power Input	High	W	49	68	81	103	122	163	172	238	280	315
	Medium	W	46	65	77	98	115	156	165	225	265	295
	Low	W	42	57	71	92	107	130	150	202	243	260
Rated Running Current	High	A	0.22	0.3	0.36	0.45	0.54	0.72	0.76	1.05	1.23	1.38
	Medium	A	0.2	0.29	0.34	0.43	0.51	0.69	0.73	1	1.18	1.31
	Low	A	0.19	0.26	0.32	0.42	0.49	0.59	0.69	0.92	1.11	1.19
Lw Outlet Duct	High	dB(A)	51	51	54	58	58	59	57	60	63	64
	Medium	dB(A)	50	50	53	57	56	58	55	59	62	63
	Low	dB(A)	48	45	48	49	52	53	49	53	57	55
Lw Inlet + Rad	High	dB(A)	56	56	59	61	63	65	62	66	67	69
	Medium	dB(A)	55	55	58	60	62	64	61	65	66	68
	Low	dB(A)	52	49	53	53	57	59	54	58	60	60
Sound Pressure Level	High	dB(A)	39	39	41	43	44	47	44	47	49	49.5
	Medium	dB(A)	38	38	40	42	43	46	43	46	48	48.5
	Low	dB(A)	34.5	32	35	35.5	39	37	37	37.5	41	41
Filter	Type	8mm Nylon Filter										
	Access	Both Side & Bottom Withdraw										
Coil	Row No.	4										
	Working Pressure	2.0 MPa										
	Material	Copper tube & Hydrophilic Aluminum										
	Water Volume	L	0.64	0.91	0.98	1.1	1.25	1.32	1.8	1.87	2.16	2.38
Fan	Type	Galvanized Steel Centrifugal Fan (Forward)										
	Quantity		1	2	2	2	2	2	3	3	4	4
Motor	Type	3 Speed PSC Motor										
	Quantity		1	1	1	1	1	1	2	2	2	2
	IP/ Insulation		IP20 / ≥B									

**NOTES:**

- 1) All performance is tested under 230V~/50Hz and unit couple with return air plenum and 8mm nylon filter.
- 2) The air flow, power input, sound data is tested on standard air condition without water in coil.
- 3) The capacity is tested under M speed, 50Pa and below condition:  
 ---District Cooling capacity: Entering air DB/WB: 24°C/18°C, water inlet 5.5°C, water outlet 14.5°C
- 4) The sound pressure is measured according to GB/T 19232-2019 (1m below the unit bottom).  
 The sound power level is measured according to "Eurovent 8/12 Sound test method for ducted fan coil unit".

# FWW-V Horizontal Ceiling Concealed Fan Coil Unit

## Dimensions

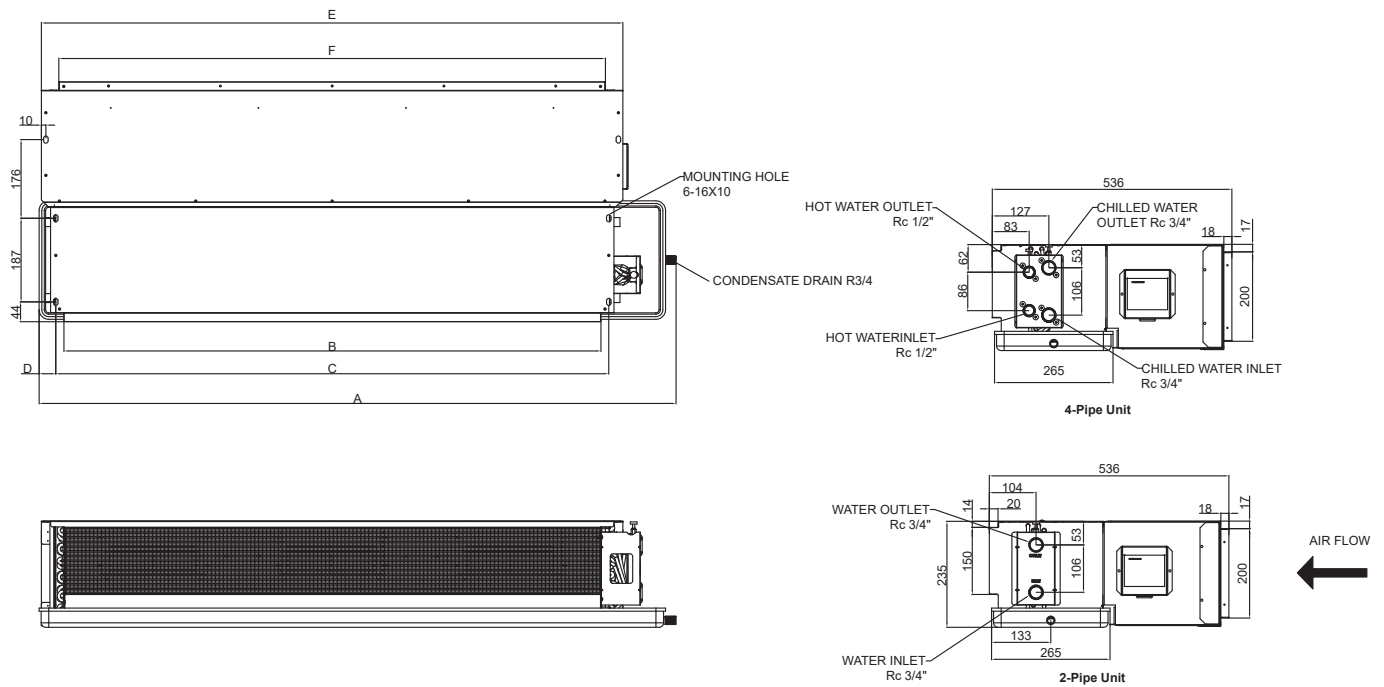

Unit: mm

Model	A		B	C	D	E	F	Package Dimension (L*D*H) mm	Net Weight (kg)		Gross Weight (kg)	
	Standard drain pan	Extend drain pan							3 rows	4 rows / 3+1 rows	3 rows	4 rows / 3+1 rows
FWW200V	625	825	401	437	37	501	423	641*250*558	13.3	13.8	15.2	15.9
FWW300V	815	1015	591	627	37	691	613	831*250*558	16.6	17.4	18.9	19.7
FWW400V	865	1065	641	677	37	741	663	881*250*558	18.2	19	20.6	21.4
FWW500V	945	1145	721	757	37	821	743	961*250*558	19.8	20.4	22.4	22.9
FWW600V	1045	1245	821	857	37	921	843	1061*250*558	21.3	21.9	24.1	24.6
FWW700V	1095	1295	871	907	37	971	893	1111*250*558	22	23.2	24.8	26
FWW800V	1425	1625	1201	1237	37	1301	1223	1441*250*558	31.8	33.4	35.3	36.9
FWW1000V	1475	1675	1251	1289	37	1351	1273	1491*250*558	34.2	35.9	37.8	39.5
FWW1200V	1675	1875	1451	1487	37	1551	1473	1691*250*558	38.4	40.3	42.5	44.4
FWW1400V	1825	2025	1601	1637	37	1701	1623	1841*250*558	41.5	43.6	45.8	47.9

## Exploded-View & Part List

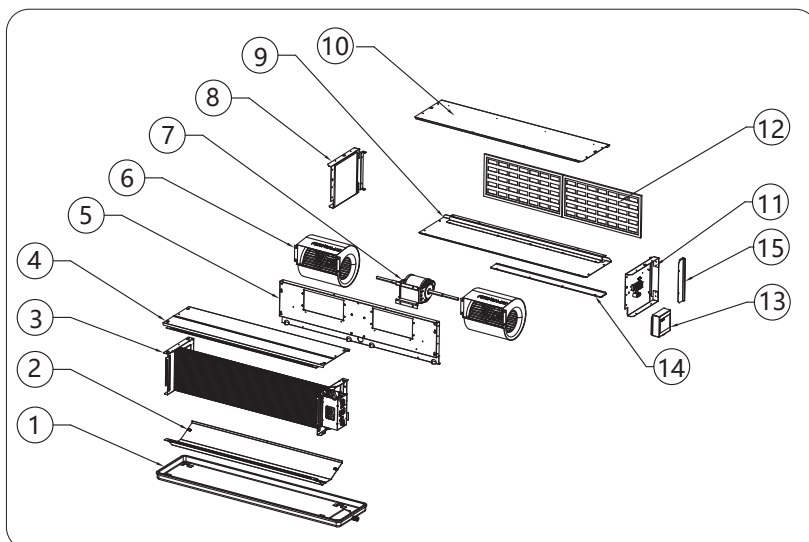

Items	Description
1	Drain pan
2	Deflector
3	Coil
4	Top panel
5	Fan deck
6	Fan
7	Motor
8	Air plenum left plate
9	Air plenum bottom plate
10	Air plenum top plate
11	Air plenum right plate
12	Filter
13	Wiring box
14	Bottom filter cover
15	Side filter cover



## FWW-T Large Air Flow Fan Coil Unit

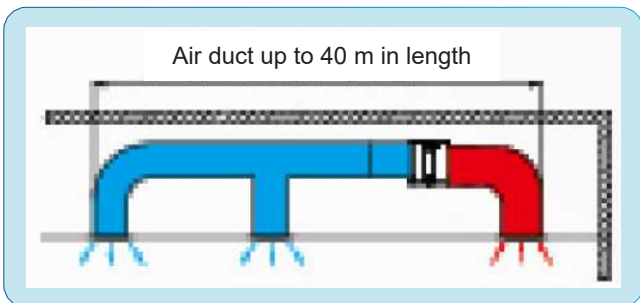

### ► Wide application

By using the large air flow and high static pressure design, the unit can meet requirements for large air flow and high static pressure, and flexibly meet application requirements on different occasions.



### ► Quiet operation

The unit is equipped with a low-noise, wide-impeller, and low-speed fan. Moreover, each fan is checked and inspected before delivery. The interior of the fan is adhered with efficient damping and heat insulating material to ensure quiet and efficient operation of the unit.



### ► Compact and space-saving structure

By using a compact structure design, the unit requires a small space for each unit, therefore saving the mounting space.

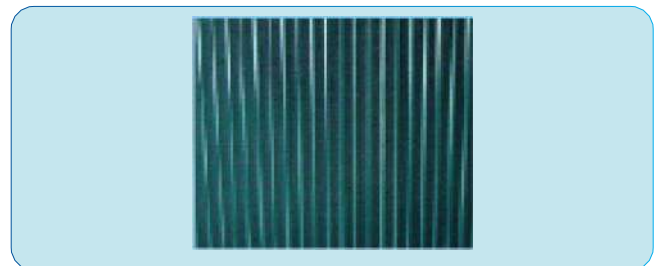

### ► High efficiency and reliability

The coil fin, made of hydrophilic aluminum and made through precision machining, ensures good heat exchange. The standard configuration includes a one-piece rubber insulating tilt drain pan that is molded to avert condensation and leakage.

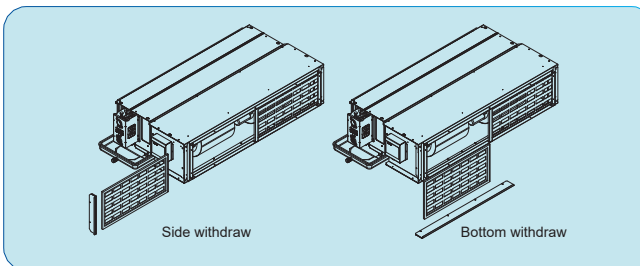

### ► Easy maintenance

With unique design, the filter can be withdraw from either bottom or side. Users can clean or replace the filter much easier.



### ► Authoritative certificate

For the whole series, we comply with AHRI 400 Standard. For district cooling unit, Eurovent certificate is granted.

# Nomenclature

1	2	3	4	5	6	7	8	9	10	11	12	13	14	15	16	17	18
F	W	W	1	0	0	0	T	A	N	R	E	F	-	A	0	A	E

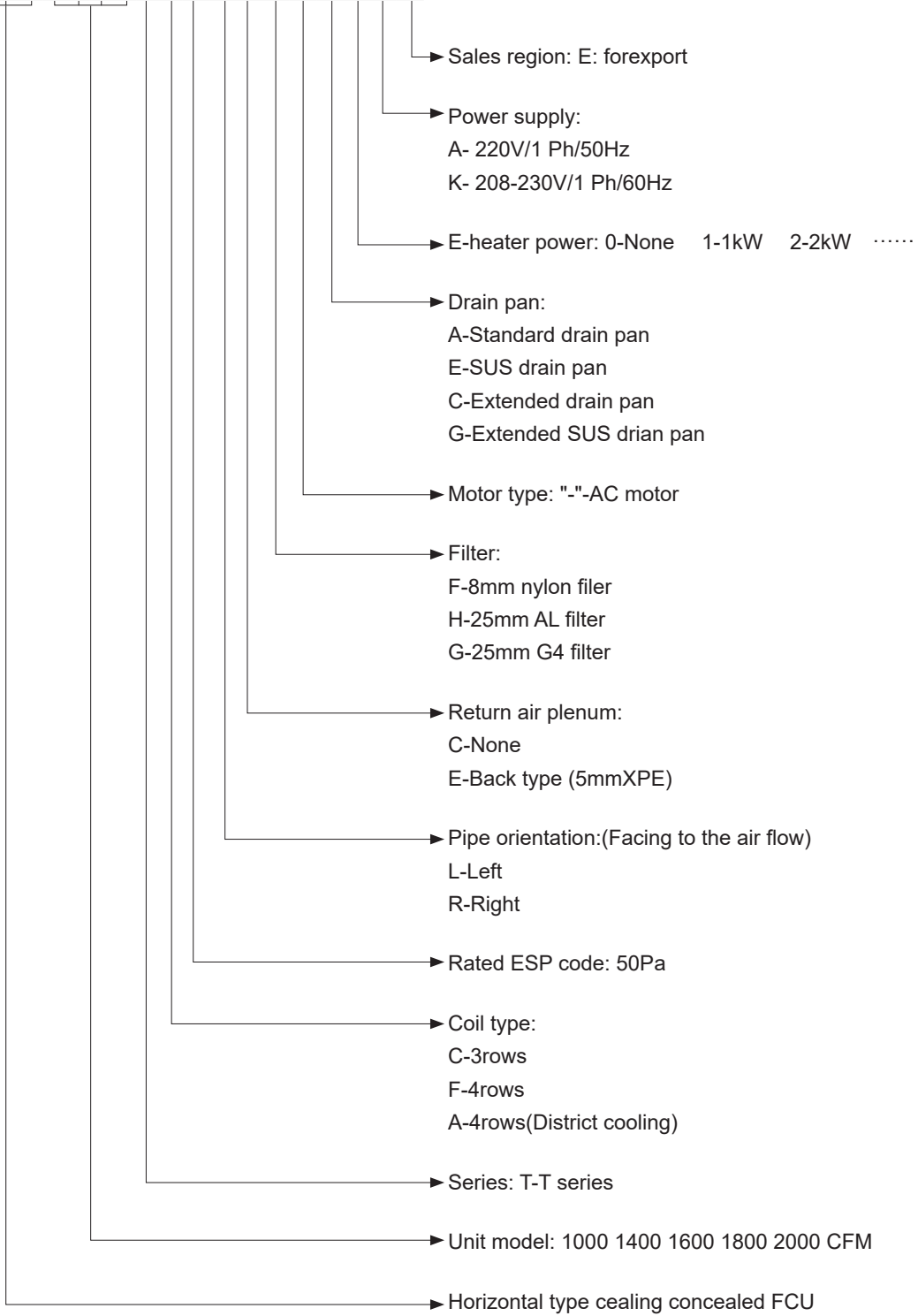

## FWW-T Ceiling Concealed Fan Coil Unit

### Standard Unit / 2-Pipe / 3 Rows

		Model	FWW1000TC	FWW1400TC	FWW1600TC	FWW1800TC	FWW2000TC
Air Flow	High	m <sup>3</sup> /h	1670	2180	2700	3150	3600
		CFM	982	1282	1588	1853	2118
	Medium	m <sup>3</sup> /h	1550	2000	2400	2970	3350
		CFM	912	1176	1412	1747	1971
	Low	m <sup>3</sup> /h	1200	1650	1960	2550	2500
		CFM	706	971	1153	1500	1471
ESP	Medium	Pa	50				
		in.wg.	0.2				
Total Cooling Capacity		W	8800	11200	13230	14890	17700
		Btu/h	30026	38214	45141	50805	60392
Water Flow Rate		m <sup>3</sup> /h	1.51	1.92	2.27	2.55	3.03
		USGPM	6.64	8.45	9.99	11.22	13.33
Water Pressure drop		kPa	30	42	47	30	57
		in.wg.	120	169	189	120	229
Rated Power Input	High	W	250	410	531	612	769
	Medium	W	230	370	420	550	704
	Low	W	165	280	310	450	465
Rated Running Current	High	A	1.1	1.8	2.33	2.69	3.38
	Medium	A	1.02	1.64	1.86	2.44	3.12
	Low	A	0.76	1.28	1.42	2.06	2.13
Sound Pressure Level	High	dB(A)	48	50	53	55	55.5
	Medium	dB(A)	46	49	51	54	54
	Low	dB(A)	41	44	47	51	51
Filter	Type	8mm Nylon Filter					
	Access	Both Side & Bottom Withdraw					
Coil	Row No.	3					
	Working Pressure	2.0 MPa					
	Material	Copper tube & Hydrophilic Aluminum					
	Water Volume	L	1.29	1.51	1.66	1.89	2.29
Fan	Type	Galvanized Steel Centrifugal Fan (Forward)					
	Quantity		2	2	2	2	2
Motor	Type	3 Speed PSC Motor					
	Quantity		1	1	1	1	1
	IP/Insulation		IP20 / ≥B				

#### NOTES:

- 1) All performance is tested under 230V~/50Hz and unit couple with return air plenum and 8mm nylon filter.
- 2) The air flow, power input, sound data is tested on standard air condition without water in coil.
- 3) The capacity is tested under M speed, 50Pa and below condition:  
---Cooling capacity: Entering air DB/WB: 27°C/19.5°C, water inlet 7°C, water outlet 12°C
- 4) The sound pressure is measured according to GB/T 19232-2019 (1m below the unit bottom).

## FWW-T Ceiling Concealed Fan Coil Unit

### Standard Unit / 2-Pipe / 4 Rows

		Model	FWW1000TF	FWW1400TF	FWW1600TF	FWW1800TF	FWW2000TF
Air Flow	High	m <sup>3</sup> /h	1670	2180	2700	3150	3600
		CFM	982	1282	1588	1853	2118
	Medium	m <sup>3</sup> /h	1550	2000	2400	2970	3350
		CFM	912	1176	1412	1747	1971
	Low	m <sup>3</sup> /h	1200	1650	1960	2550	2500
		CFM	706	971	1153	1500	1471
ESP	Medium	Pa	50				
		in.wg.	0.2				
Total Cooling Capacity		W	10000	12900	14700	17500	20600
		Btu/h	34120	44015	50156	59710	70287
Water Flow Rate		m <sup>3</sup> /h	1.71	2.21	2.52	3	3.53
		USGPM	7.52	9.72	11.09	13.20	15.53
Water Pressure drop		kPa	37	40	45	55	63
		in.wg.	149	161	181	221	253
Rated Power Input	High	W	250	410	531	612	769
	Medium	W	230	370	420	550	704
	Low	W	165	280	310	450	465
Rated Running Current	High	A	1.1	1.8	2.33	2.69	3.38
	Medium	A	1.02	1.64	1.86	2.44	3.12
	Low	A	0.76	1.28	1.42	2.06	2.13
Sound Pressure Level	High	dB(A)	48	50	53	55	55.5
	Medium	dB(A)	46	49	51	54	54
	Low	dB(A)	41	44	47	51	51
Filter	Type	8mm Nylon Filter					
	Access	Both Side & Bottom Withdraw					
Coil	Row No.	4					
	Working Pressure	2.0 MPa					
	Material	Copper tube & Hydrophilic Aluminum					
	Water Volume	L	1.72	2.01	2.21	2.52	3.06
Fan	Type	Galvanized Steel Centrifugal Fan (Forward)					
	Quantity	2	2	2	2	2	
Motor	Type	3 Speed PSC Motor					
	Quantity	1	1	1	1	1	
	IP/Insulation	IP20 / ≥B					

#### NOTES:

- 1) All performance is tested under 230V~/50Hz and unit couple with return air plenum and 8mm nylon filter.
- 2) The air flow, power input, sound data is tested on standard air condition without water in coil.
- 3) The capacity is tested under M speed, 50Pa and below condition:  
---Cooling capacity: Entering air DB/WB: 27°C/19.5°C, water inlet 7°C, water outlet 12°C
- 4) The sound pressure is measured according to GB/T 19232-2019 (1m below the unit bottom).

# FWW-T Ceiling Concealed Fan Coil Unit

## District Cooling Unit / 2-Pipe / 4 Rows



		Model	FWW1000TA	FWW1400TA	FWW1600TA	FWW1800TA	FWW2000TA
Air Flow	High	m <sup>3</sup> /h	1670	2180	2700	3150	3600
		CFM	982	1282	1588	1853	2118
	Medium	m <sup>3</sup> /h	1550	2000	2400	2970	3350
		CFM	912	1176	1412	1747	1971
	Low	m <sup>3</sup> /h	1200	1650	1960	2550	2500
		CFM	706	971	1153	1500	1471
ESP	Medium	Pa	50				
		in.wg.	0.2				
Total Cooling Capacity		W	7700	9600	11600	13300	15600
		Btu/h	26272	32755	39579	45380	53227
Water Flow Rate		m <sup>3</sup> /h	0.73	0.91	1.1	1.27	1.49
		USGPM	3.21	4.00	4.84	5.59	6.56
Water Pressure drop		kPa	44	42	42	42	36
		in.wg.	177	169	169	169	145
Rated Power Input	High	W	250	410	531	612	769
	Medium	W	230	370	420	550	704
	Low	W	165	280	310	450	465
Rated Running Current	High	A	1.1	1.8	2.33	2.69	3.38
	Medium	A	1.02	1.64	1.86	2.44	3.12
	Low	A	0.76	1.28	1.42	2.06	2.13
Lw Outlet Duct	High	dB(A)	63	65	69	70	70
	Medium	dB(A)	61	63	67	69	69
	Low	dB(A)	56	60	64	68	64
Lw Inlet + Rad	High	dB(A)	66	66	72	75	73
	Medium	dB(A)	64	65	70	74	72
	Low	dB(A)	59	61	66	71	66
Sound Pressure Level	High	dB(A)	48	50	53	55	55.5
	Medium	dB(A)	46	49	51	54	54
	Low	dB(A)	41	44	47	51	51
Filter	Type	8mm Nylon Filter					
	Access	Both Side & Bottom Withdraw					
Coil	Row No.	4					
	Working Pressure	2.0 MPa					
	Material	Copper tube & Hydrophilic Aluminum					
	Water Volume	L	1.72	2.01	2.21	2.52	3.06
Fan	Type	Galvanized Steel Centrifugal Fan (Forward)					
	Quantity		2	2	2	2	2
Motor	Type	3 Speed PSC Motor					
	Quantity		1	1	1	1	1
	IP/Insulation		IP20 / ≥B				

**NOTES:**

- 1) All performance is tested under 230V~/50Hz and unit couple with return air plenum and 8mm nylon filter.
- 2) The air flow, power input, sound data is tested on standard air condition without water in coil.
- 3) The capacity is tested under M speed, 50Pa and below condition:  
 ---District Cooling capacity: Entering air DB/WB: 24°C/18°C, water inlet 5.5°C, water outlet 14.5°C
- 4) The sound pressure is measured according to GB/T 19232-2019 (1m below the unit bottom).  
 The sound power level is measured according to "Eurovent 8/12 Sound test method for ducted fan coil unit".

# FWW-T Ceiling Concealed Fan Coil Unit

## Dimensions

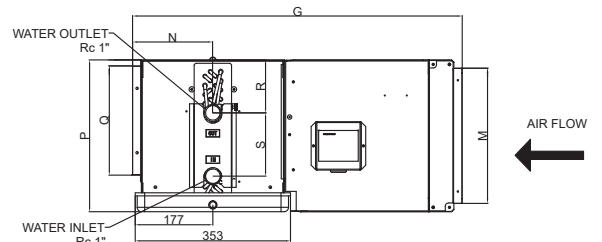
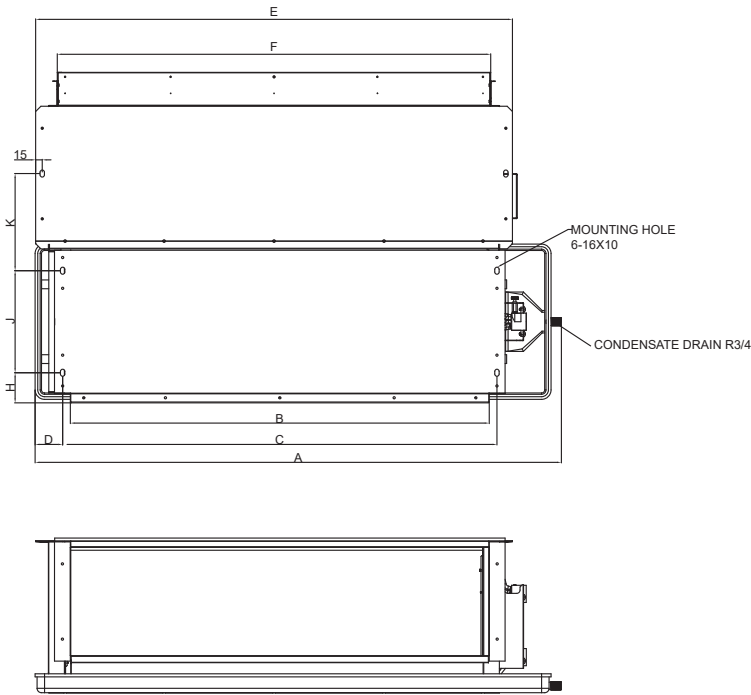

Model	A		G	P	B	C	D	E	F	H	J	K	M	N	Q	R	S
	Standard drain pan	Extend drain pan															
FWW1000T	1195	1395	585	290	952	987	48	1085	1006	65	150	227	254	127	202	66	143
FWW1400T	1195	1395	750	345	952	987	50	1085	985	68	232	221	307	183	248	123	143
FWW1600T	1295	1495	750	345	1053	1087	50	1185	1085	68	232	221	307	183	248	123	143
FWW1800T	1445	1645	750	345	1201	1237	50	1335	1235	68	232	221	307	183*	248	123	143
FWW2000T	1445	1645	780	390	1201	1237	50	1335	1235	68	232	266	354	183*	300	62	250

Unit: mm

Model	Package Dimension (L*D*H) mm	Net Weight (kg)		Gross Weight (kg)	
		3 rows	4 rows	3 rows	4 rows
FWW1000T	1211*305*608	34.9	35.7	38.9	39.7
FWW1400T	1211*360*773	50.5	51.6	55	56
FWW1600T	1311*360*773	51.6	52.7	56.8	57.9
FWW1800T	1461*360*773	57.6	58.7	63.3	64.4
FWW2000T	1461*405*803	62.7	64.1	68.5	70

Remark: The water pipe location of FWW1800TF and FWW2000TF is different. Please refer to below drawing.

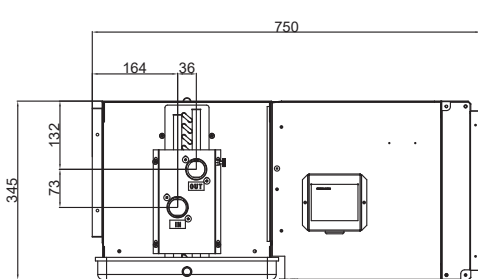

\*Water pipe location for FWW1800TF

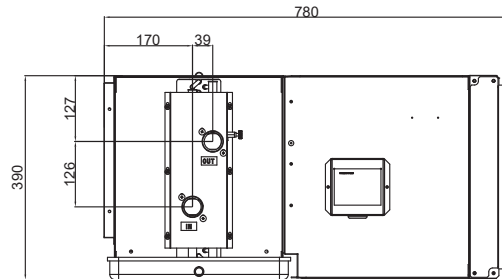

\*Water pipe location for FWW2000TF



### FWW-AA Horizontal Exposed Fan Coil



#### ► Novel shape and ultra-thin size

The ultra-thin design reduces the space required. The novel shape makes the interior decoration more brilliant.



#### ► District cooling application

The unique circuit design and the application of large temperature difference optimize the overall cooling performance of the unit.

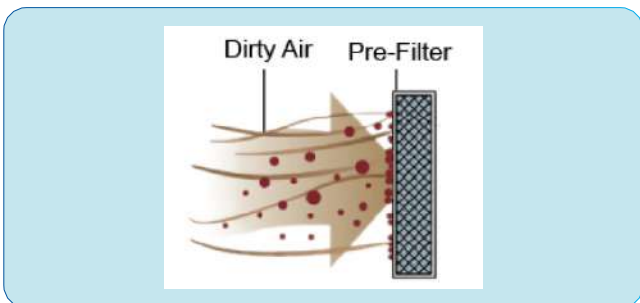

#### ► Primary-efficiency filter for health & comfort

A cleanable primary-efficiency filter of nylon screen is configured at the air inlet to effectively filter out the dust from the air and guarantee the indoor air quality.



#### ► Easy installation and convenient maintenance

Due to ceiling installation, it is not required to specially decorate the wall and ceiling.

The standard configuration of the unit includes a back air return inlet where the filter can be easily removed and replaced.

## Nomenclature

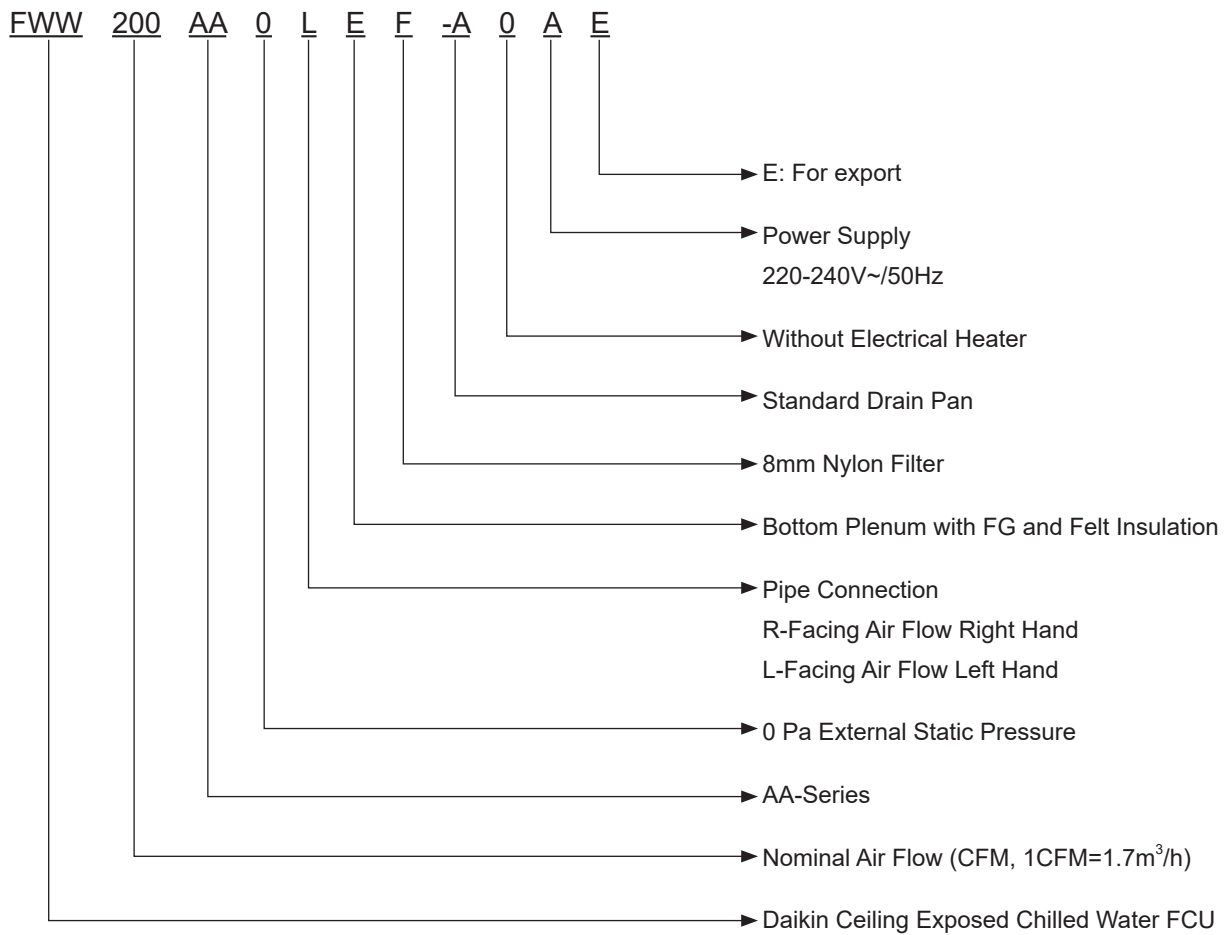

# FWW-AA Ceiling Exposed Fan Coil Unit

## District Cooling Unit/2-pipe/4 Rows

MODEL			200AA	300AA	400AA	600AA	800AA	1000AA	1200AA	1400AA
Air flow	High	m <sup>3</sup> /h	340	510	680	1020	1360	1700	2040	2380
	Medium	m <sup>3</sup> /h	279	418	558	836	1115	1394	1673	1952
	Low	m <sup>3</sup> /h	170	255	340	510	680	850	1020	1190
Total cooling capacity		W	2125	3385	4390	6207	8096	10165	11066	13744
Sensible capacity		W	1233	2059	2848	4179	5572	7125	7961	9770
Water flow		m <sup>3</sup> /h	0.21	0.33	0.43	0.6	0.79	0.99	1.07	1.32
Water pressure drop		kPa	5	13	22	16	16	25	20	29
Rated power input		W	39	53	72	107	142	183	217	239
Rated running current		A	0.18	0.24	0.33	0.48	0.65	0.83	0.99	1.09
Sound pressure level	High	dB(A)	36	40	43	46	46	50	50	51
	Medium	dB(A)	32	36	36	42	42	47	47	46
	Low	dB(A)	23	25	29	30	32	38	36	37
Coil										
Tube material		Copper								
Fin material		Hydrophilic aluminum								
Filter withdraw										
Bottom return	8mm nylon filter	Bottom withdraw								
Max. working pressure		2.0MPa								
Cooling water pipe size		Rc 3/4 Female thread								
Condensation water pipe size		R3/4 Male thread								
		Fan								
Type		Galvanized steel double stage impeller forward centrifugal								
Quantity		1	2	2	2	3	4	4	4	4
		Motor								
Type		3 speed permanent split capacitor motor								
Quantity		1	1	1	1	2	2	2	2	2
Insulation class		IP20/B								

### NOTES:

- 1) All performance is tested under 220V~/50Hz and unit couple with return air plenum and 8mm nylon filter.
- 2) The air flow, power input, sound data is tested on standard air condition without water in coil.
- 3) The cooling capacity are being tested under following condition:  
H speed, entering air db/wb: 27°C/19.5°C, water inlet 5°C, water outlet 15°C
- 4) Sound pressure measured at 1m in front of the unit and 1m below the vertical center line of the unit, and tested in semi-anechoic room, with background sound pressure level: 11.5db (a).
- 5) When the water connect direction is changed in field, the capacity should be reduced by 15%.
- 6) For medium speed, the capacity is about 87% of high speed.  
For low speed, the capacity is about 60% of high speed.

# FWW-AA Ceiling Exposed Fan Coil Unit

## Dimensions

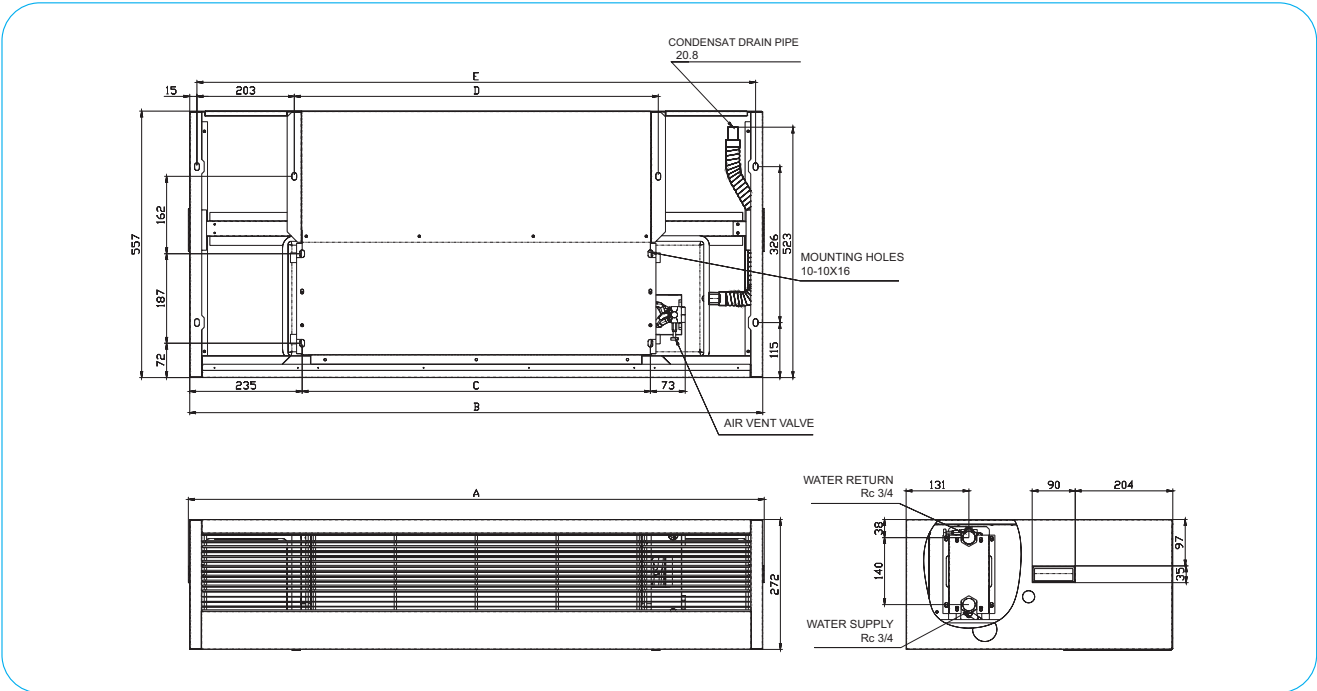

Unit: mm

Unit model	A	B	C	D	E	Package dimension (L×H×W) mm	Net weight (kg)	Gross weight (kg)
FWW200AA	963	957	488	520	927	970×565×300	30	32
FWW300AA	1103	1097	628	660	1067	1110×565×300	35	38
FWW400AA	1203	1197	728	760	1167	1210×565×300	39	42
FWW600AA	1383	1377	908	940	1347	1390×565×300	44	48
FWW800AA	1713	1707	1238	1270	1677	1720×565×300	61	66
FWW1000AA	1813	1807	1338	1370	1777	1820×565×300	66	71
FWW1200AA	2013	2007	1538	1570	1977	2020×565×300	73	78
FWW1400AA	2273	2267	1798	1830	2237	2280×565×300	83	89

## Exploded-View & Part List

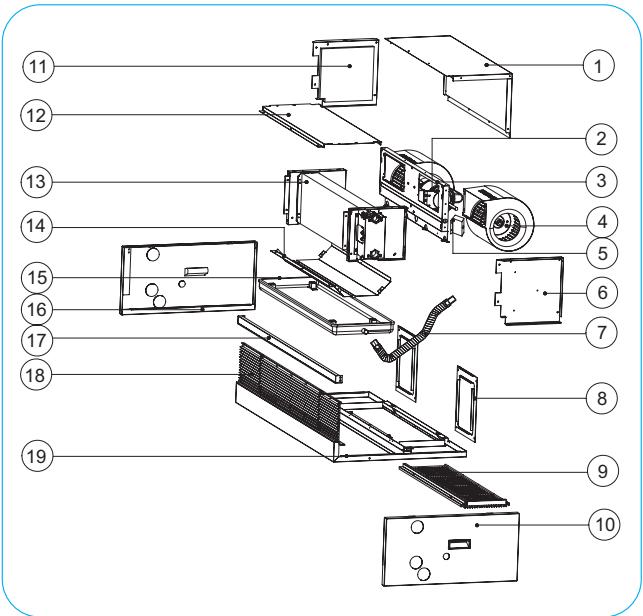

Item	Description
1	Top panel for air return plenum
2	Motor
3	Fan deck
4	Fan
5	Terminal box
6	Right side plate of air return box
7	Condensate drain pipe
8	Back support plate
9	Filter and grille
10	Right side plate
11	Left side plate of return air box
12	Top plate
13	Coil assy
14	Deflector
15	Drain pan
16	Left side plate
17	Front cross beam
18	Air supply grille
19	Bottom panel

## FUW-A Ultra-thin ceiling unit for High ESP application

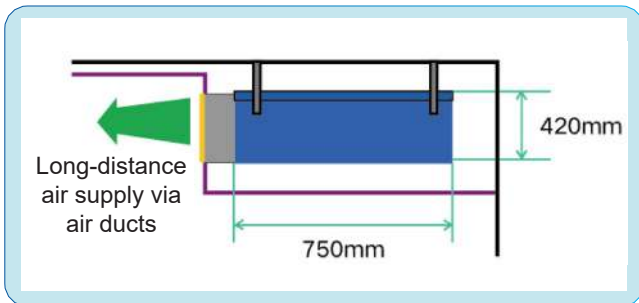

### ► Flat body

The unit adopts a flat design to reduce its height and depth for a small drop ceiling.

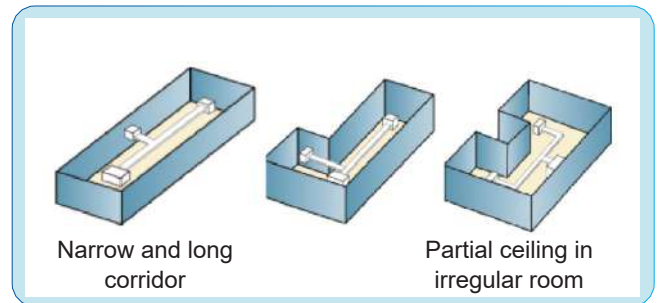

### ► High static pressure air supply

The unit adopts a high static pressure design to extend the air supply distance, thus being applicable to a variety of irregular rooms.

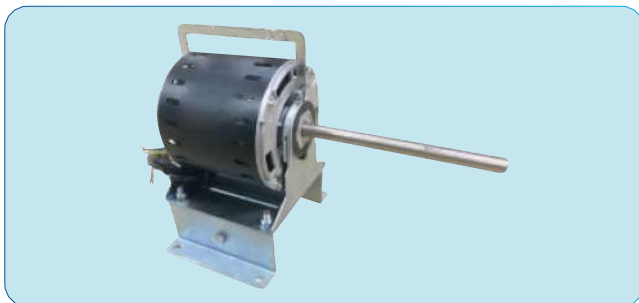

Efficient and direct driven motor



Double-inlet forward centrifugal fan with multiple wings

### ► Direct-driven fan motor

No belt abrasion, no maintenance, reliable operation, and low failure rate

# Nomenclature

## High ESP Ceiling Unit FUW-A

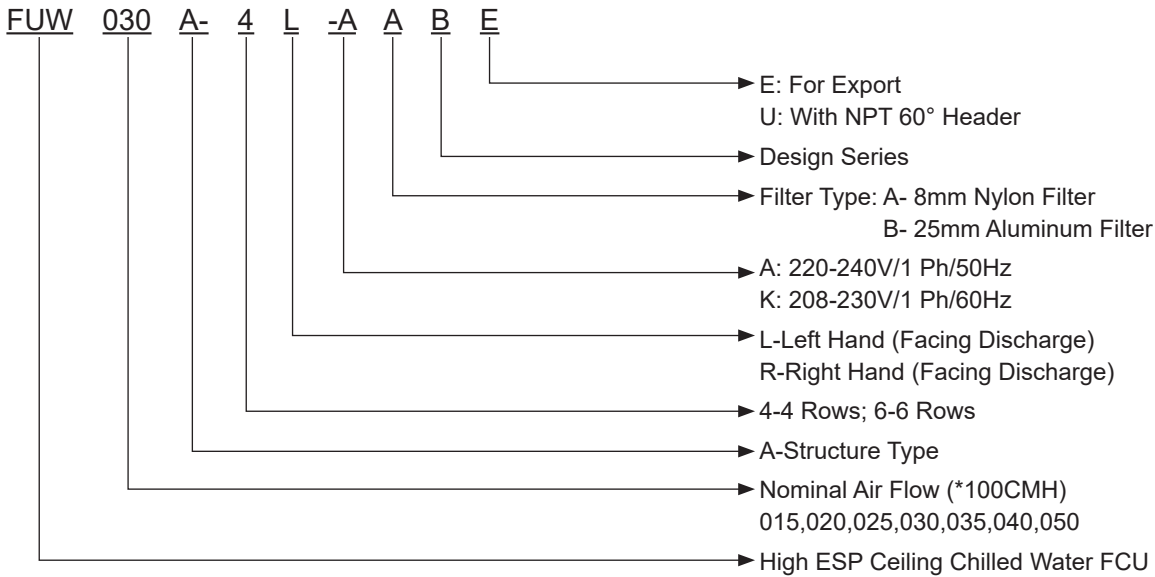

## Exploded-View & Part List

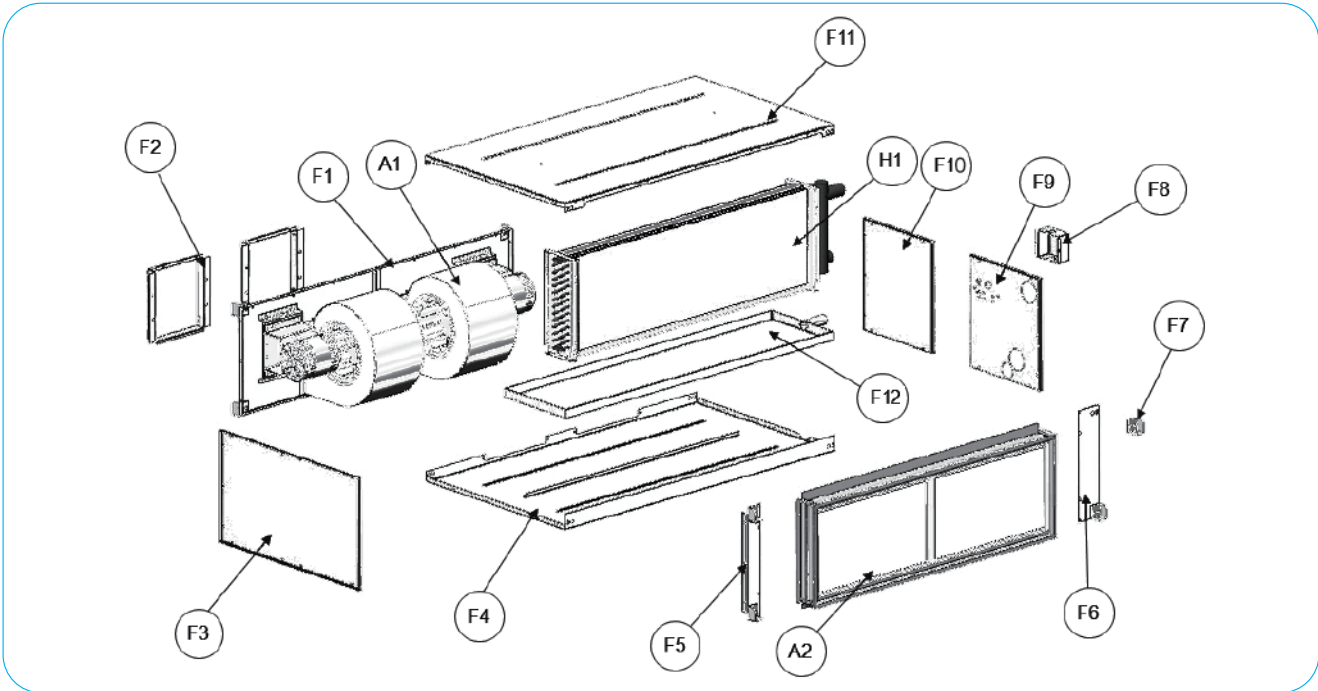

A1	FAN MOTOR ASSY.	F4	BASE PANEL ASSY.	F9	SIDE PANEL DRAIN
A2	FILTER ASSY.	F5	R COIL BAFFLE	F10	SIDE PANEL ACCESS
F1	FRONT PANEL	F6	L COIL BAFFLE	F11	TOP PANEL
F2	COLLAR ASSY.	F7	TOP FIX	F12	DRAIN PAN ASSY.
F3	SIDE PANEL WIDE	F8	TERMINAL BOX	H1	COIL ASSY.

# FUW-A Ultra-thin ceiling unit for High ESP application

## Standard Unit/2-pipe/4 or 6 Rows

Model			FUW015A	FUW020A	FUW025A	FUW030A	FUW035A	FUW040A	FUW050A
Nominal air flow		m <sup>3</sup> /h	1500	2000	2500	3000	3500	4000	5000
External static pressure (ESP)		Pa	70	100	100	120	120	150	150
Nominal capacity	Cooling	4 Rows(return air)	7	12	13	17	20	23	30
		4 Rows(fresh air)	18	27	33	41	47	53	64
		6 Rows(return air)	10	14	18	22	26	30	38
		6 Rows(fresh air)	24	33	42	50	57	65	78
	Heating	4 Rows(return air)	13	19	22	27	32	36	46
		4 Rows(fresh air)	22	30	37	44	52	59	75
		6 Rows(return air)	16	22	27	33	38	44	55
		6 Rows(fresh air)	26	35	43	52	61	70	88
Water flow	Cooling	4 Rows(return air)	0.34	0.57	0.64	0.79	0.93	1.08	1.42
		4 Rows(fresh air)	0.88	1.29	1.59	1.93	2.25	2.51	3.05
		6 Rows(return air)	0.48	0.67	0.86	1.05	1.23	1.43	1.83
		6 Rows(fresh air)	1.15	1.59	2.01	2.38	2.72	3.08	3.72
	Heating	4 Rows(return air)	0.31	0.44	0.53	0.64	0.75	0.87	1.1
		4 Rows(fresh air)	0.51	0.72	0.87	1.05	1.23	1.41	1.78
		6 Rows(return air)	0.38	1.51	0.65	0.78	0.91	1.04	1.31
		6 Rows(fresh air)	0.61	0.83	1.03	1.24	1.45	1.67	2.08
Water pressure drop	Cooling	4 Rows(return air)	1	26	5	9	13	19	37
		4 Rows(fresh air)	7	80	29	46	60	66	77
		6 Rows(return air)	4	8	14	22	33	47	87
		6 Rows(fresh air)	18	37	65	79	87	95	112
	Heating	4 Rows(return air)	1	14	3	5	8	11	20
		4 Rows(fresh air)	2	34	8	13	19	27	49
		6 Rows(return air)	2	4	7	11	16	23	41
		6 Rows(fresh air)	5	10	17	26	38	53	93
220-240V~/50Hz	Rated power input	4 Rows	368	488	977	790	874	1335	1864
		6 Rows	407	680	886	830	916	1450	1646
	Rated running current	4 Rows	1.67	2.25	4.48	3.66	4.13	6.25	8.52
		6 Rows	1.87	3.18	4.07	2.95	4.23	5.54	7.56
208-230V~/60Hz	Rated power input	4 Rows	305	455	601	687	833	1060	1220
		6 Rows	307	509	625	765	860	1017	1217
	Rated running current	4 Rows	1.33	2.01	2.75	2.98	3.89	3.96	5.55
		6 Rows	1.34	2.22	2.68	3.45	3.91	4.44	5.31
Sound pressure level	High	dB(A)	44.1	50.6	55.7	52.5	53.5	53.6	57
	Medium	dB(A)	40.7	48	52.2	50.5	52.1	51.5	56
	Low	dB(A)	37.7	45.1	48.4	48.5	50.2	49.5	54.9
Structure	Type	Galvanized steel coated with electrostatic spraying. Internal gued with insulation PE							
Coil	Type	Corrugated aluminum fin mechanically bonded with copper tube							
	Max. working pressure(MPa)	1.6							
	Inlet/outlet pipe	R1½"							
	Condensing water pipe	R¾"							
Filter withdraw	8mm nylon filter	Side withdraw							
	25mm aluminum filter	Side withdraw							
Fan	Type/material	Centrifugal forward curved blower and galvanized steel							
	Fan no.	1				2			
Motor	Type	Single phase capacitor running							
	Quantity	1				2			
	Insulation class	IP20 B							

### NOTES:

- All performance are tested under 220V~/50Hz and unit couple with 8mm nylon filter.
- The air flow, power input, sound data is tested on standard air condition without water in coil.
- The cooling capacity are being tested under following condition:  
 Return air cooling conditions: 27°C/19.5°C WB; fresh air cooling conditions: 34°C DB/28°C WB  
 Cooling water entering/leaving conditions: 7°C/12°C  
 Return air heating condition: 21°C DB; fresh air heating condition: 0°C DB;  
 Heating water entering/leaving conditions: 60°C/50°C
- Sound pressure measured at 1m in front of the unit and 1m below the vertical center line of the unit,  
 And tested in semi-anechoic room with background sound pressure level: 11.5DB(a)

# FUW-A Ultra-thin ceiling unit for High ESP application

## Dimensions

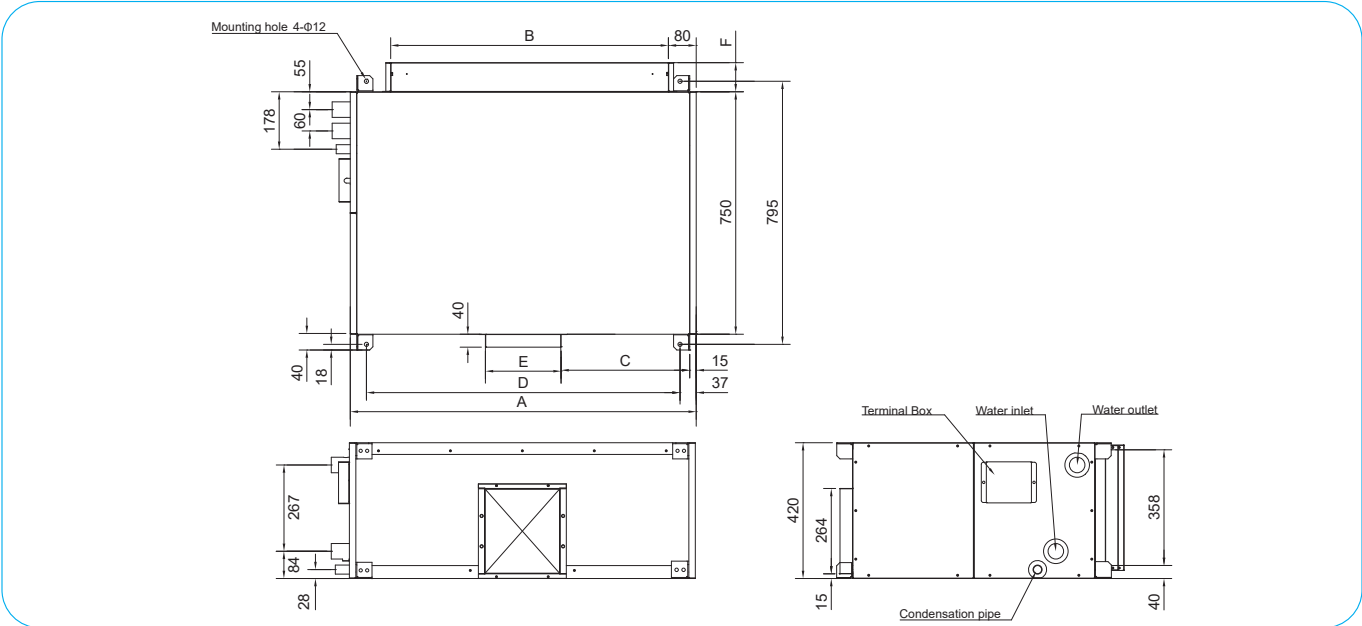

Unit: mm

Model	Dimension					F		Package dimension (L×H×W) mm	Net weight (kg)	
	A	B	C	D	E	8mm nylon filter	25mm AL filter		4 rows	6 rows
FUW015A	740	540	237	666	236	77	90	930×590×930	76	79
FUW020A	900	700	317	826	236	77	90	1090×590×930	80	84
FUW025A	1060	860	397	986	236	77	90	1250×590×930	86	90

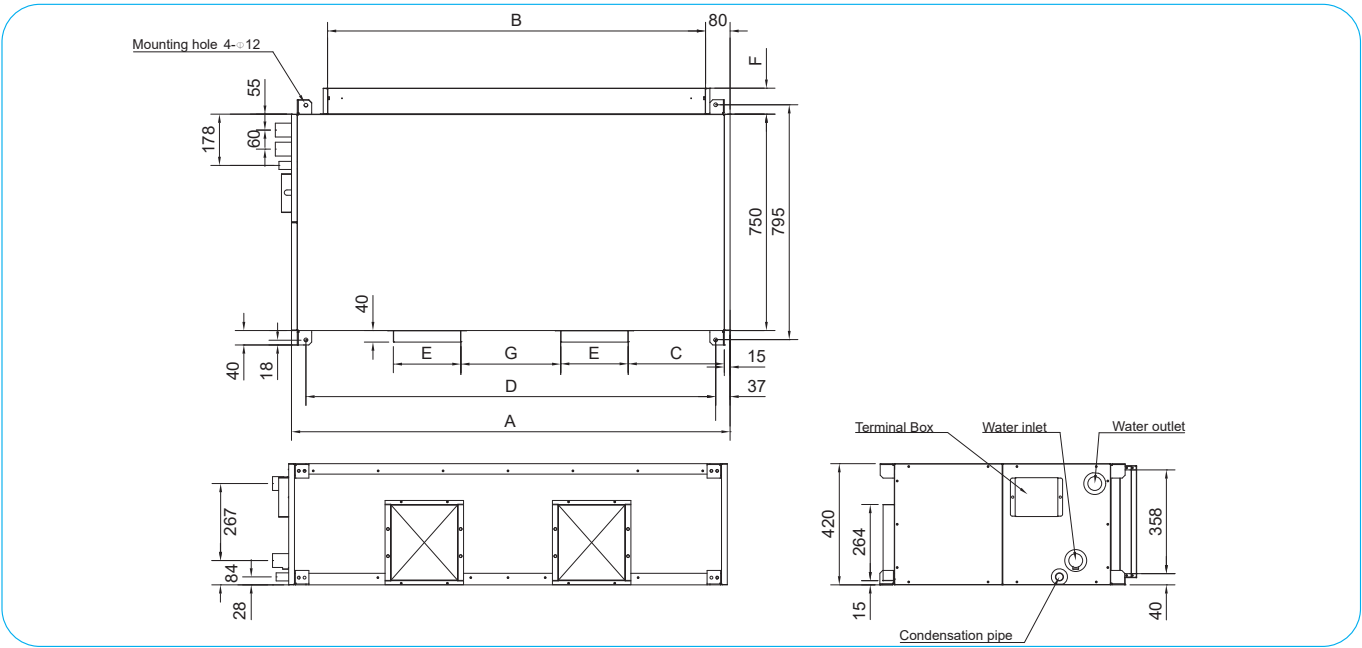

Unit: mm

Model	Dimension					F		G	Package dimension (L×W×H) mm	Net weight (kg)	
	A	B	C	D	E	8mm nylon filter	25mm AL filter			4 rows	6 rows
FUW030A	1210	1010	282	1136	236	77	90	174	1400×590×930	92	96
FUW035A	1360	1160	337	1286	236	77	90	214	1540×590×930	96	101
FUW040A	1510	1310	347	1436	236	77	90	344	1700×590×930	102	107
FUW050A	1840	1640	412	1766	236	77	90	544	2030×590×930	108	113

# FUW-A Ultra-thin ceiling unit for High ESP application

## Electric Heating Box for FUW-A Unit

### ► Electric Heating Box Power

Electric Box Model	Power Supply	Capacity(kW)	Electric Box Model	Power Supply	Capacity(kW)
FUW-EH-020BOX	220-240V/1Ph/50Hz; 208-230V/1Ph/60Hz	2	FUW-EH-050BOX	220-240V/1Ph/50Hz; 208-230V/1Ph/60Hz	5
FUW-EH-030BOX	220-240V/1Ph/50Hz; 208-230V/1Ph/60Hz	3	FUW-EH-060BOX	220-240V/1Ph/50Hz; 208-230V/1Ph/60Hz	6
FUW-EH-040BOX	220-240V/1Ph/50Hz; 208-230V/1Ph/60Hz	4	FUW-EH-075BOX	220-240V/1Ph/50Hz; 208-230V/1Ph/60Hz	7.5

#### NOTES:

EACH HEATER BOX CAN ONLY BE USED FOR ONE AIR DISCHARGE DUCT.

- 1) FUW015/20/025 - ONLY ONE HEATING BOX IS REQUIRED.
- 2) FUW030/035/040/050 - NEED TO SELECT TWO BOX, AND THE HEATING CAPACITY OF EACH BOX SHOULD BE REQUIRED TOTAL CAPACITY TO DIVIDE BY TWO.

### ► Dimensions of Electric Heating Box

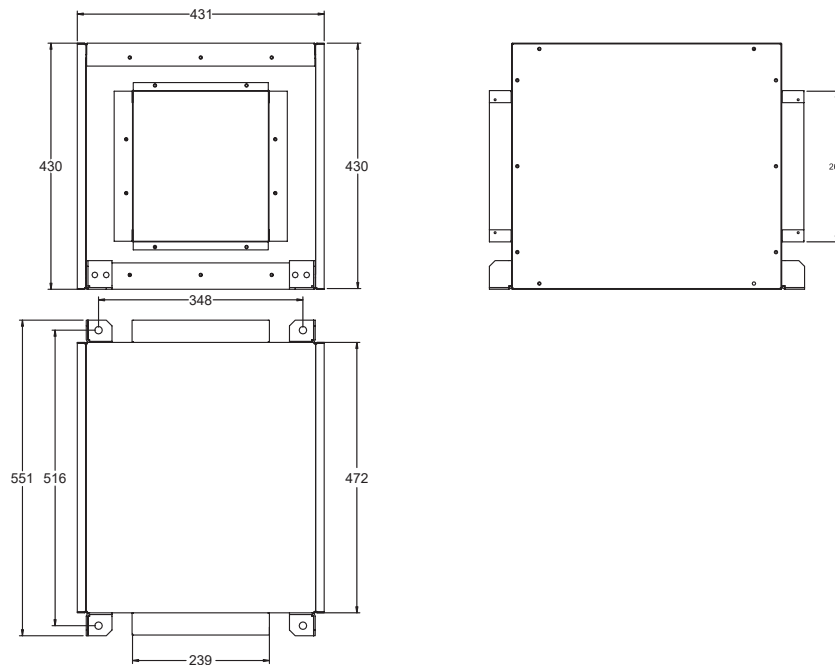

### ► Scheme of Electric Heating Box Installation

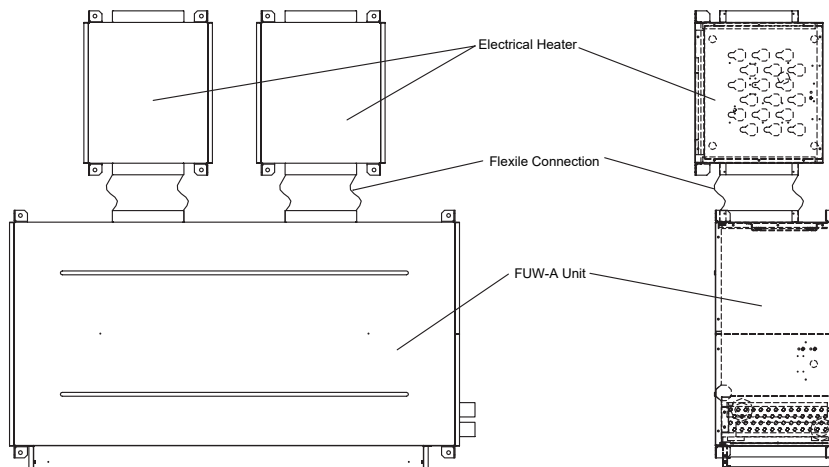

# Wiring

Electrical wiring connection must be done according to the wiring diagram on the unit.  
 The unit must be GROUNDED to the earth system of the building.  
 All field wiring must be installed in accordance with the national wiring regulation and Fire Department regulation

## FWW-V

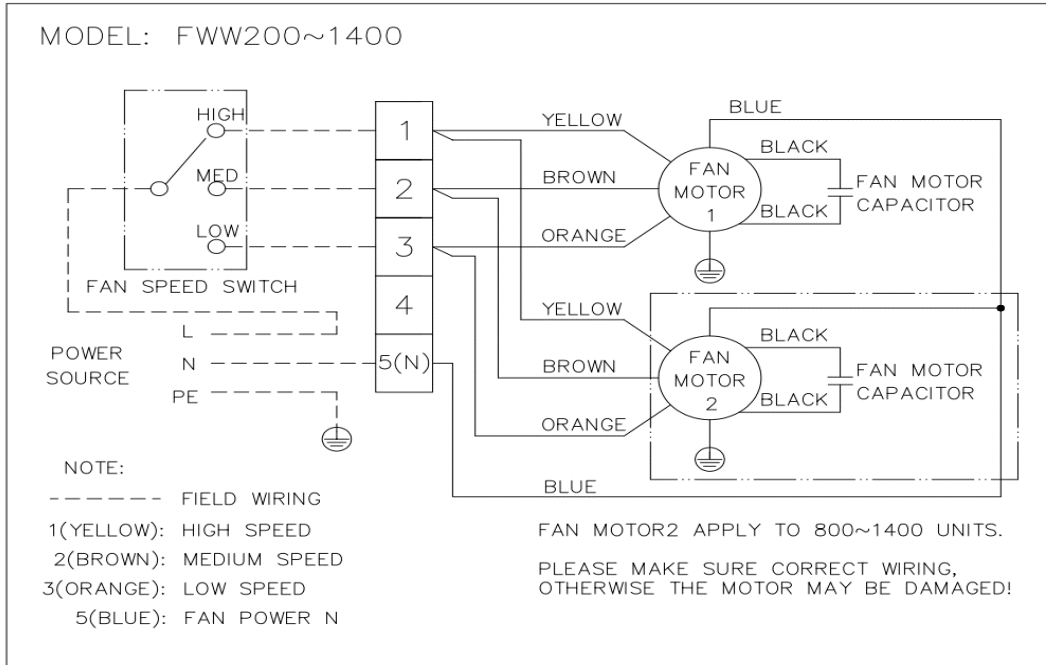

## FWW-T

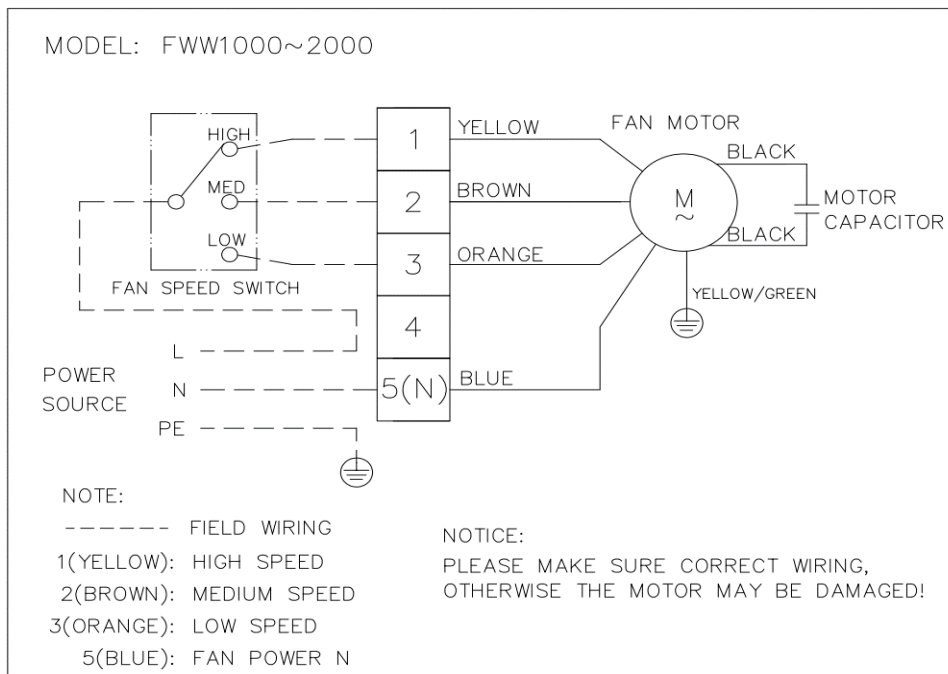

**FWW-AA**

MODEL: FWW 200~1400AA

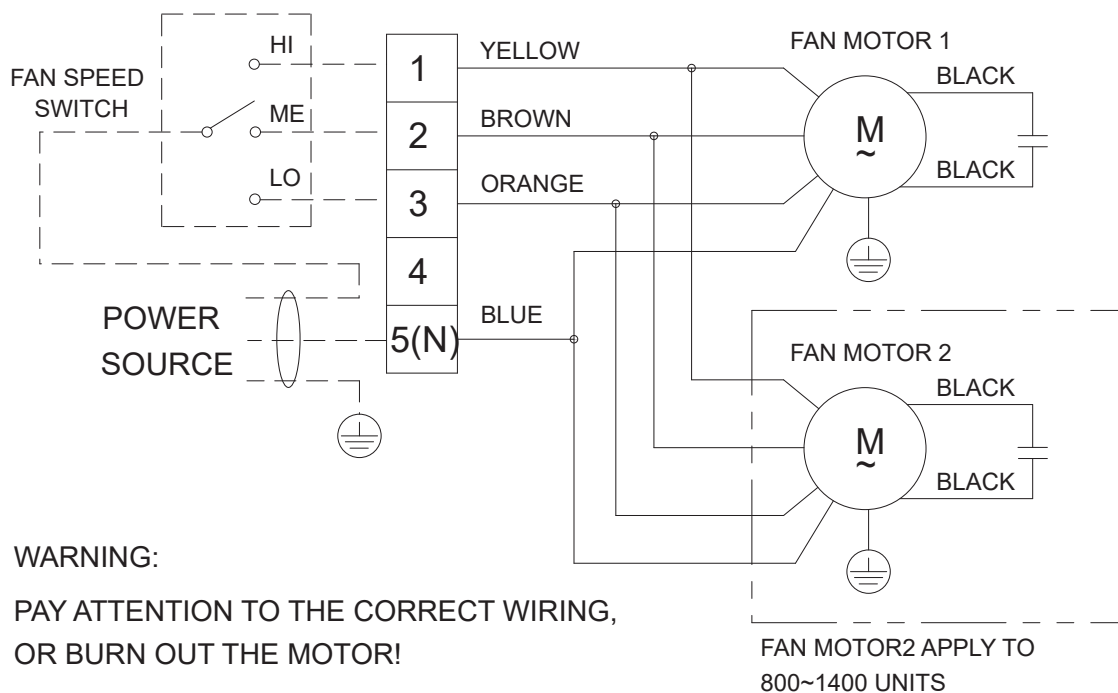

**WARNING:**  
PAY ATTENTION TO THE CORRECT WIRING,  
OR BURN OUT THE MOTOR!

----- FIELD WIRING

**FUW-A**

MODEL: FUW-A

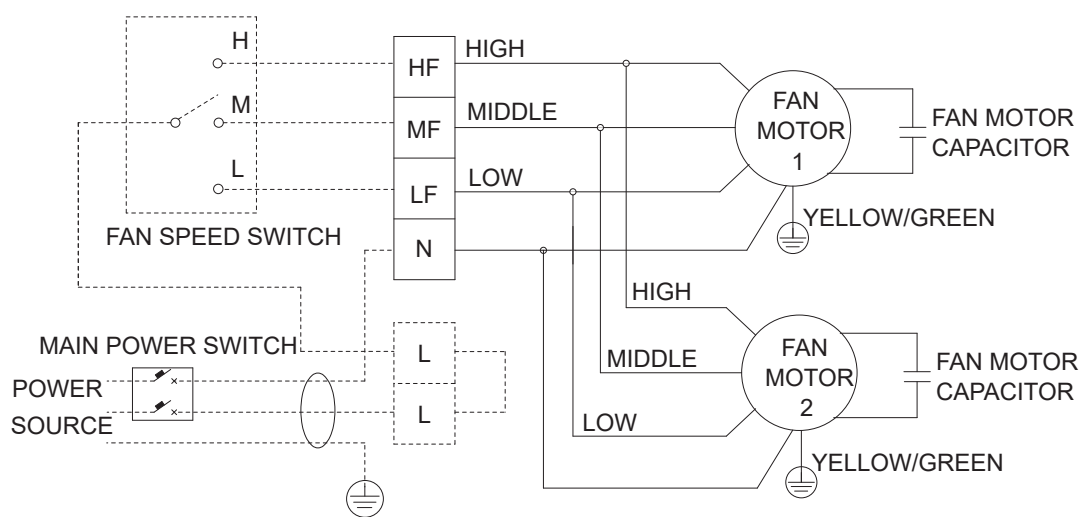

NOTE:

----- FIELD WIRING

- LF: FAN SPEED LOW
- MF: FAN SPEED MIDDLE
- HF: FAN SPEED HIGH

FAN MOTOR2 APPLY TO FUW030A/035A/040A/050A UNITS.

# Guide Specifications for FWW Unit

---

## ► Unit Description

Factory-assembled, horizontal, galvanized casing, ceiling ducted fan coil unit is complete with water coil, fans, motors, drain pan, filters and all required wiring, with full access to internal components.

## ► Quality Assurance

Each coil is factory tested for leakage at 2.5MPa air pressure with coil submerged in water. Each unit and its moving components (fans and motors) are factory computer-tested and recorded after unit is complete and before it is packed.

## ► Factory shall be certified by following standard

1. ISO 9001:2015 certification for Quality Management Systems
2. ISO 14001:2015 certification for Environmental Management Systems
3. ISO 45001:2018 certification for Occupational Health and Safety

## ► Component Specifications

### 1. Casing:

Construction is galvanized steel, lined on the inside with thermal and acoustical insulation. Return air plenum is lined with XPE and has a collar for return duct connection. Supply duct connection also has a collar. Removable bottom panel is provided for access to the fan/motor assembly.

### 2. Coil:

Standard unit is equipped with a 3-rows, 4-rows or 3+1 rows coil for installation in a 2-pipe or 4-pipe system. Coil has seamless copper tubes, fins hydrophilic aluminum bonded to the tubes by mechanical expansion.

### 3. Fan:

Direct-driven centrifugal fan wheel has forward-curved blades which are statically and dynamically balanced.

The fan housing and blades are constructed of high quality hot-galvanized steel.

### 4. Motor:

Fan motor is 3-speed, permanent split-capacitor with ball type bearing and build-in automatic reset thermal overload protection. Motors have permanently lubricated ball bearings.

### 5. Drain Pan

Drain pan shall be die-formed steel, sloped to the piping connection, which will be threaded for easy connection. Both its sides are sprayed and outer side insulated with 6mm NBR that complies with GB 8624 B1 class requirement. It extends under the full length and width of the coils and is pitched for positive drainage with features of high anti-corrosion, anti-condensation and high fire reluctance.

### 6. Filter

Filter is with washable type Nylon filter with 8mm thickness.

**Warning**

- Daikin Industries, Ltd.'s products are manufactured for export to numerous countries throughout the world. Daikin Industries, Ltd. does not have control over which products are exported to and used in a particular country. Prior to purchase, please therefore confirm with your local authorized importer, distributor and/or retailer whether this product conforms to the applicable standards, and is suitable for use, in the region where the product will be used. This statement does not purport to exclude, restrict or modify the application of any local legislation.
- Ask a qualified installer or contractor to install this product. Do not try to install the product yourself. Improper installation can result in water or refrigerant leakage, electrical shock, fire or explosion.
- Use only those parts and accessories supplied or specified by Daikin. Ask a qualified installer or contractor to install those parts and accessories. Use of unauthorized parts and accessories or improper installation of parts and accessories can result in water or refrigerant leakage, electrical shock, fire or explosion.
- Read the User's Manual carefully before using this product. The User's Manual provides important safety instructions and warnings. Be sure to follow these instructions and warnings.

If you have any enquiries, please contact your local importer, distributor and/or retailer.

**Cautions on product corrosion**

1. The units should not be installed in areas where corrosive gases, such as acid gas or alkaline gas, are produced.
2. If the unit is to be installed close to the sea shore, direct exposure to the sea breeze should be avoided. If you need to install the unit close to the sea shore, contact your local distributor.



[www.daikinmea.com](http://www.daikinmea.com)

The present publication is drawn up by way of information only and does not constitute an offer binding upon Daikin Middle East and Africa FZE has compiled the content of this publication to the best of its knowledge. No express or implied warranty is given for the completeness, accuracy, reliability or fitness for particular purpose of its content and the products and services presented therein. Specifications are subject to change without prior notice. Daikin Middle East and Africa FZE explicitly rejects any liability for any direct or indirect damage, in the broadest sense, arising from or related to the use and/or interpretation of this publication. All content is copyrighted by Daikin Middle East and Africa FZE.

**DAIKIN MIDDLE EAST AND AFRICA FZE**

P.O. Box 18674, Plot MO0426, JAFZA North, Jebel Ali Free Zone, Dubai, UAE | Tel: +971 (0) 4 815 9300 | Fax: +971 (0) 4 815 9311

E-mail: [info@daikinmea.com](mailto:info@daikinmea.com) Web: [www.daikinmea.com](http://www.daikinmea.com) Toll Free: 800-DAIKIN (324546)



CA-FCU 50Hz | 202301